

# 11 Johnathon Street

**SUBMITTED BY**

Ray White Rockhampton Casey  
stockers@cqoz.com

---

**CREATED ON**

2022-07-06

---

**Floors**

2

---

▼ Ground Floor

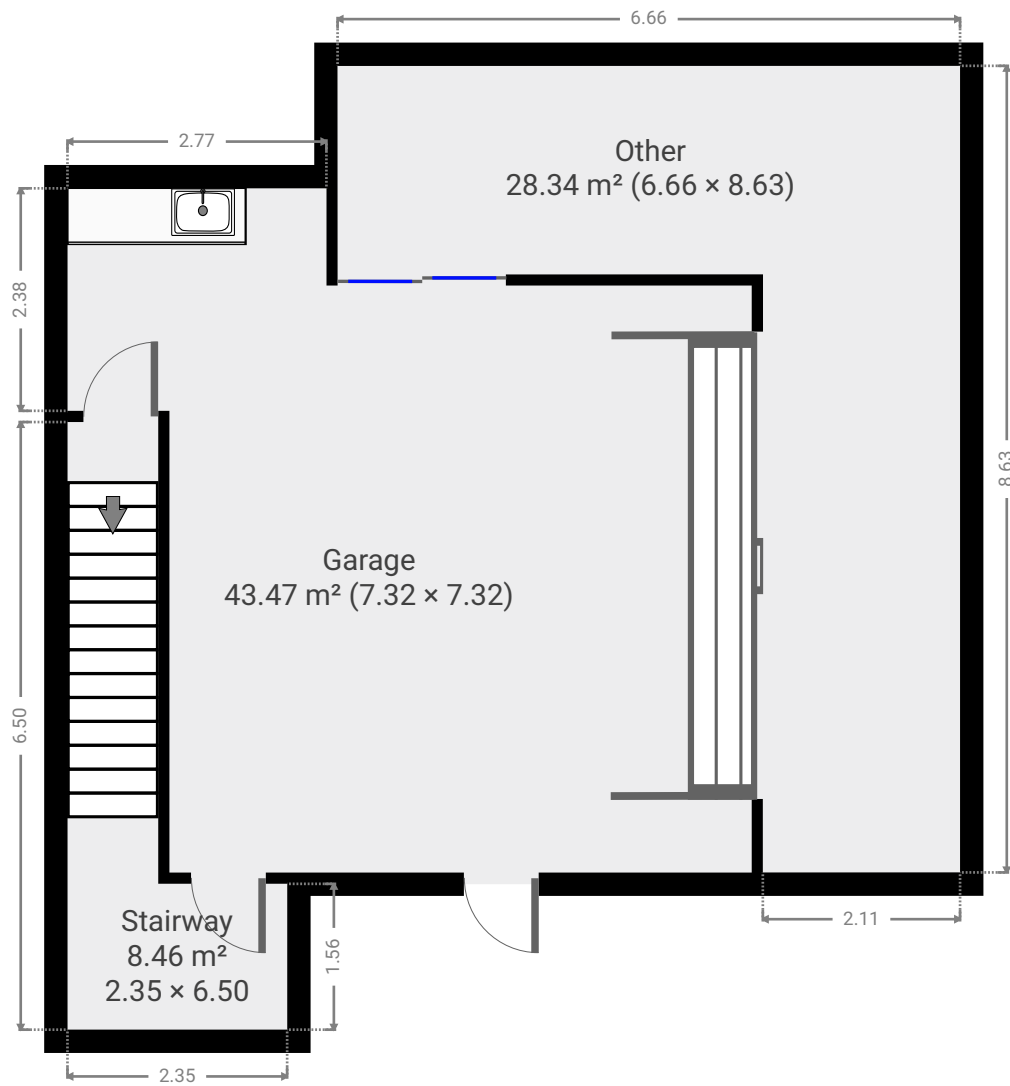

FLOORS: 2

▼ **Garage**  
Ground Floor

WIDTH: 7.32 m • LENGTH: 7.32 m  
AREA: 43.47 m<sup>2</sup> • PERIMETER: 29.28 m

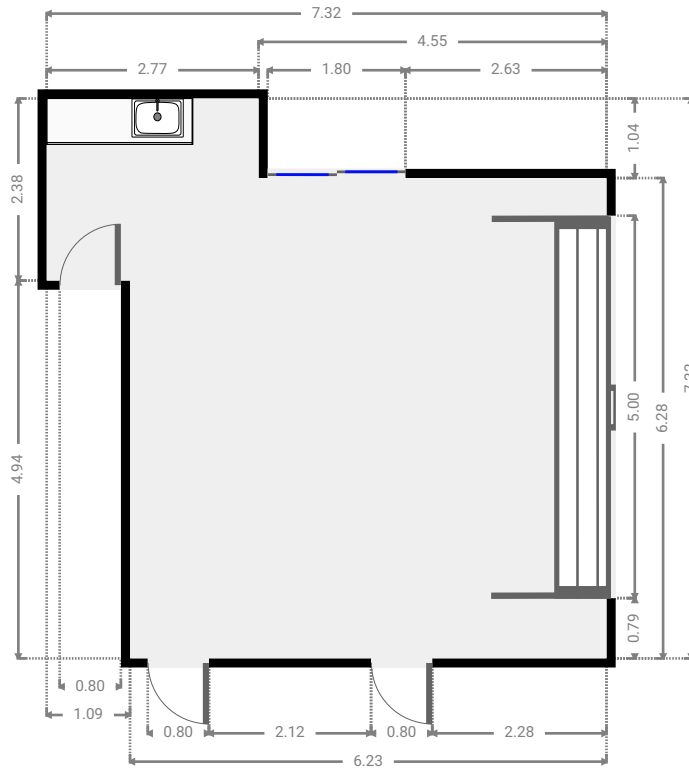
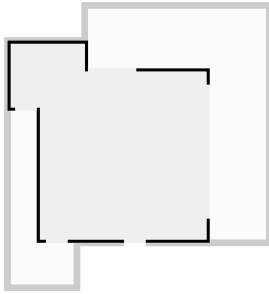

▼ **Other**  
Ground Floor

WIDTH: 6.66 m • LENGTH: 8.63 m  
AREA: 28.34 m<sup>2</sup> • PERIMETER: 30.58 m

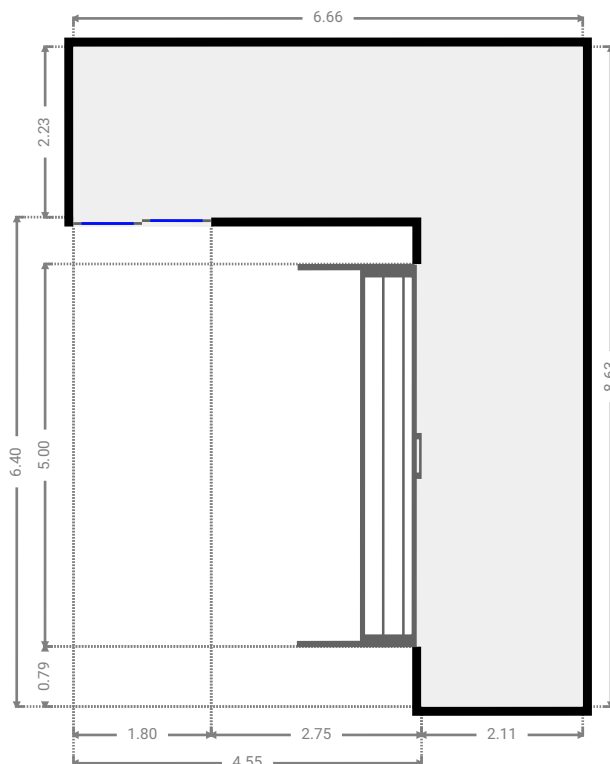
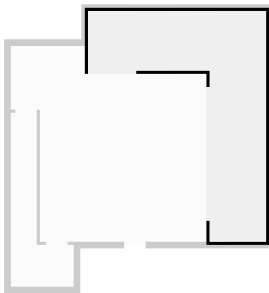

## ▼ Stairway Ground Floor

WIDTH: 2.35 m • LENGTH: 6.50 m  
AREA: 8.46 m<sup>2</sup> • PERIMETER: 17.70 m

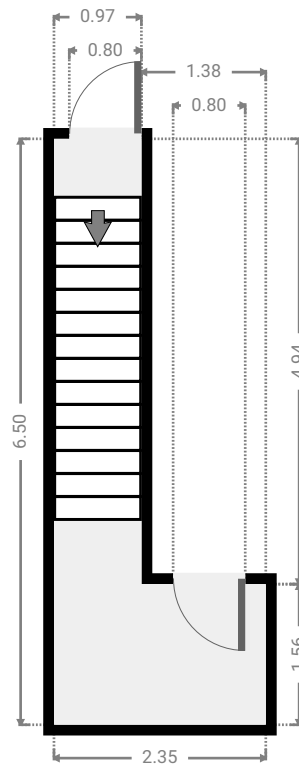
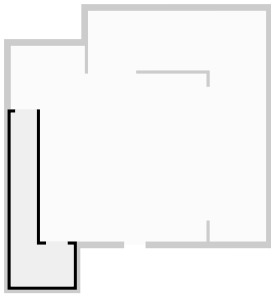

▼ 1st Floor

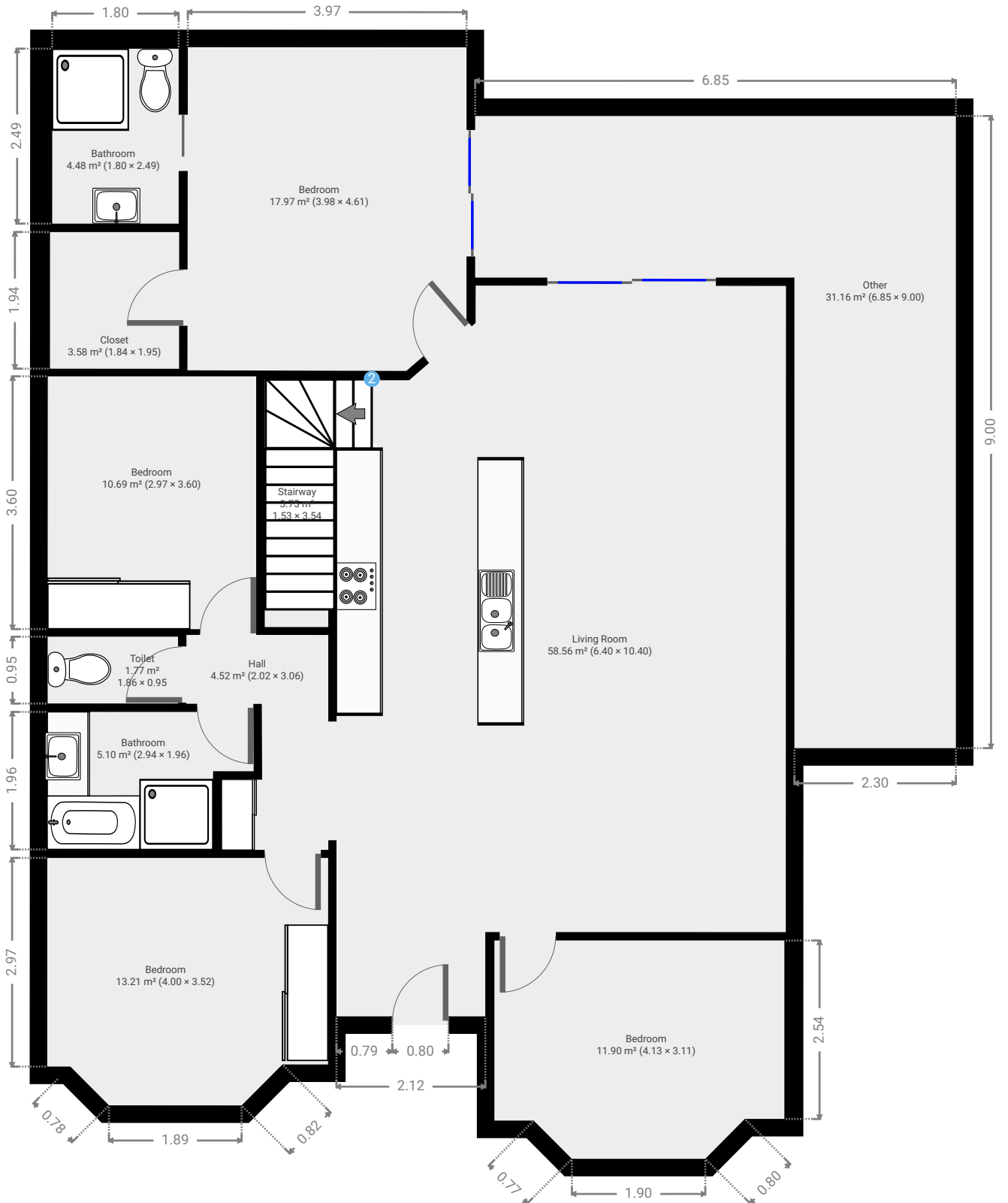

▼ **Bathroom**  
1st Floor

WIDTH: 1.80 m • LENGTH: 2.49 m  
AREA: 4.48 m<sup>2</sup> • PERIMETER: 8.58 m

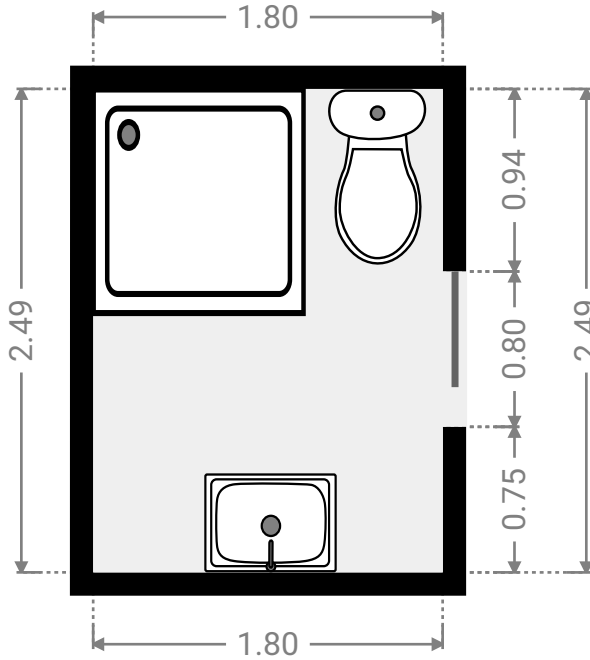
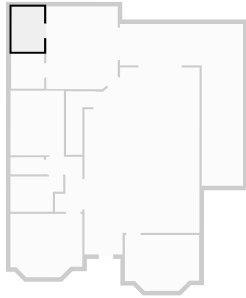

▼ **Bathroom**  
1st Floor

WIDTH: 2.94 m • LENGTH: 1.96 m  
AREA: 5.10 m<sup>2</sup> • PERIMETER: 9.79 m

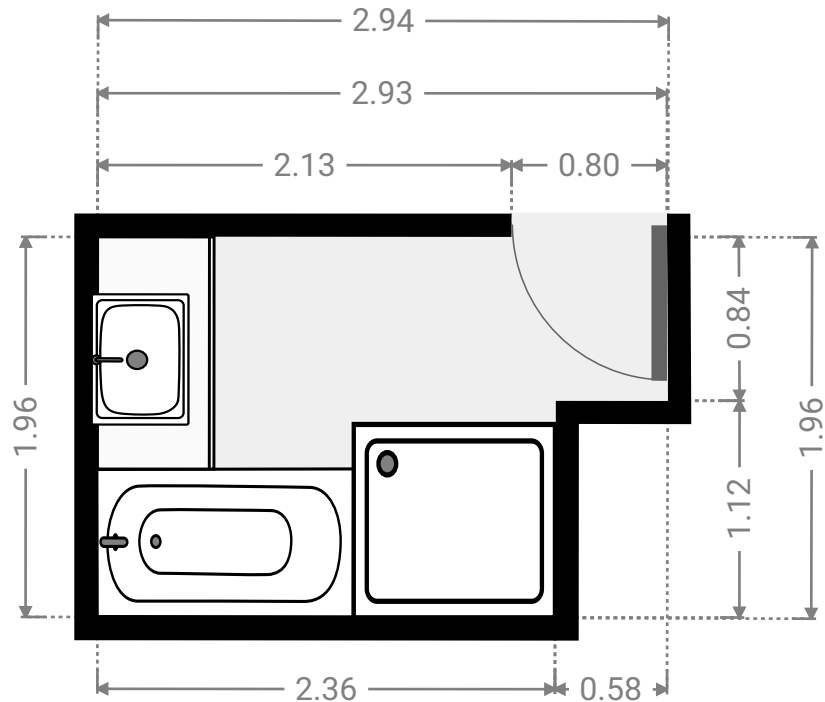
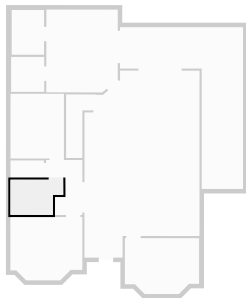

▼ **Bedroom**  
1st Floor

WIDTH: 4.13 m • LENGTH: 3.11 m  
AREA: 11.90 m<sup>2</sup> • PERIMETER: 13.83 m

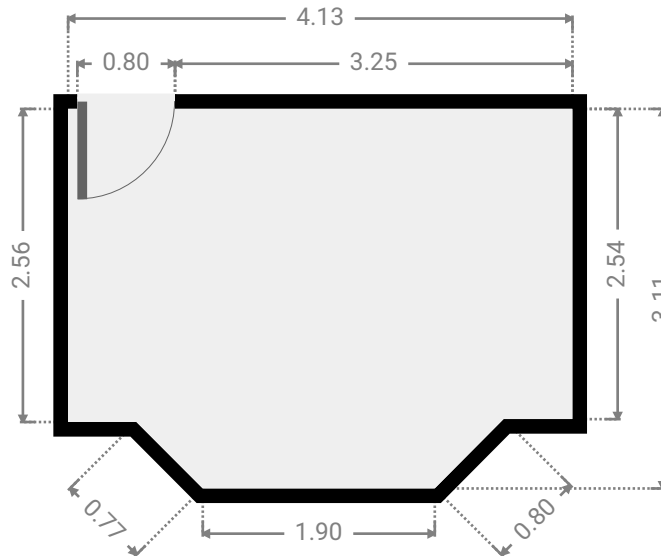
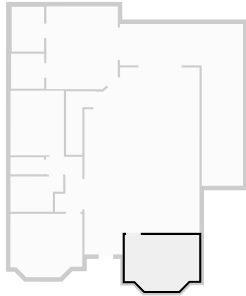

▼ **Bedroom**  
1st Floor

WIDTH: 3.98 m • LENGTH: 4.61 m  
AREA: 17.97 m<sup>2</sup> • PERIMETER: 16.69 m

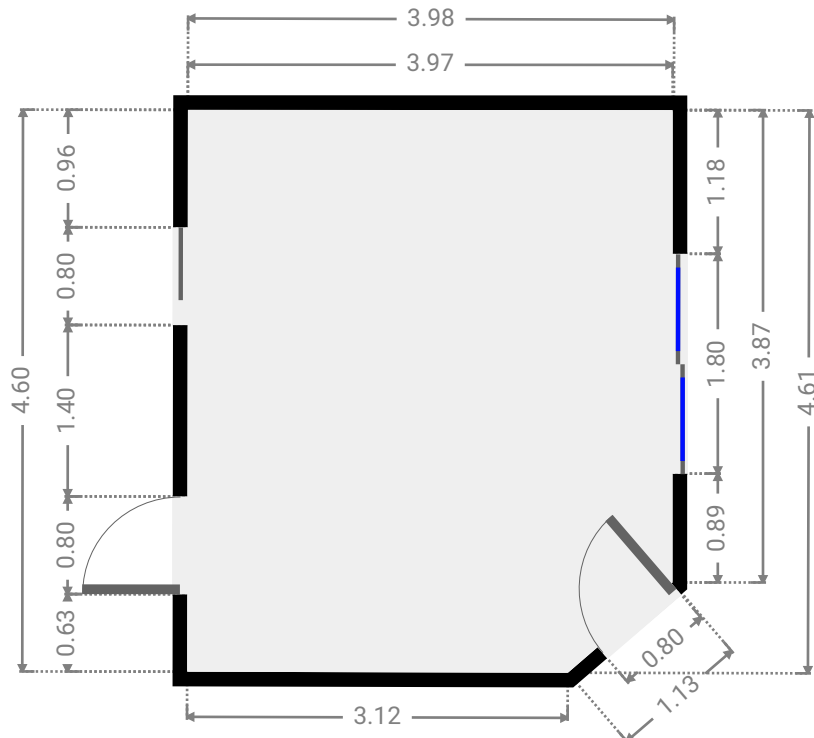
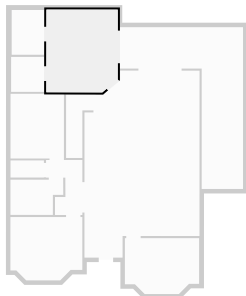

FLOORS: 2

▼ **Closet**  
1st Floor

WIDTH: 1.84 m • LENGTH: 1.95 m  
AREA: 3.58 m<sup>2</sup> • PERIMETER: 7.57 m

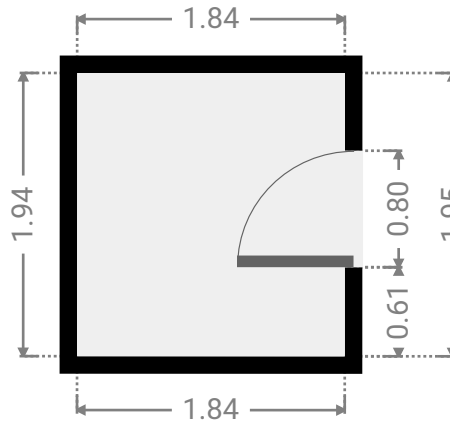
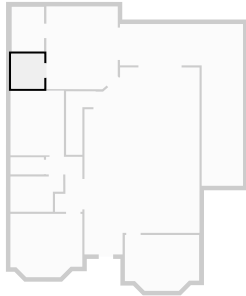

▼ **Bedroom**  
1st Floor

WIDTH: 4.00 m • LENGTH: 3.52 m  
AREA: 13.21 m<sup>2</sup> • PERIMETER: 14.38 m

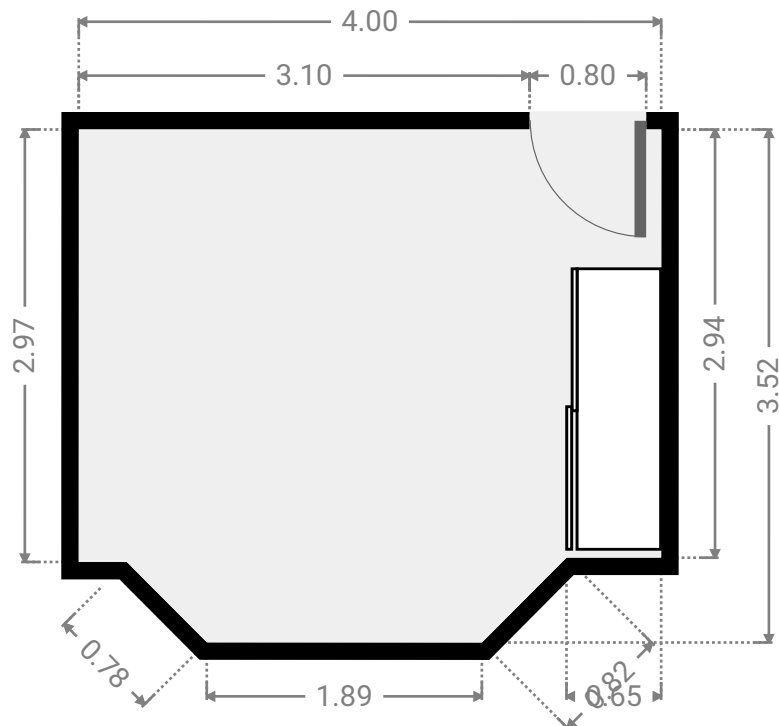
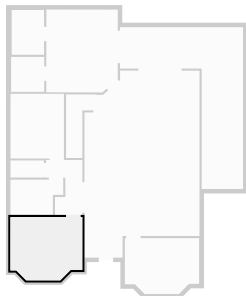



▼ **Bedroom**  
1st Floor

WIDTH: 2.97 m • LENGTH: 3.60 m  
AREA: 10.69 m<sup>2</sup> • PERIMETER: 13.14 m

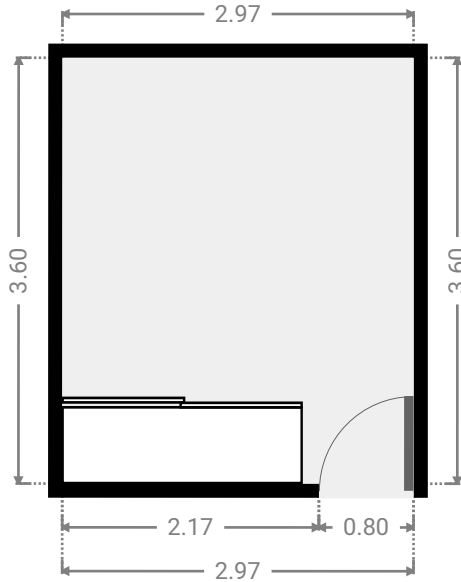
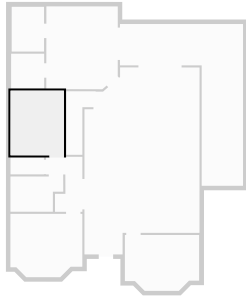

▼ **Hall**  
1st Floor

WIDTH: 2.02 m • LENGTH: 3.06 m  
AREA: 4.52 m<sup>2</sup> • PERIMETER: 11.31 m

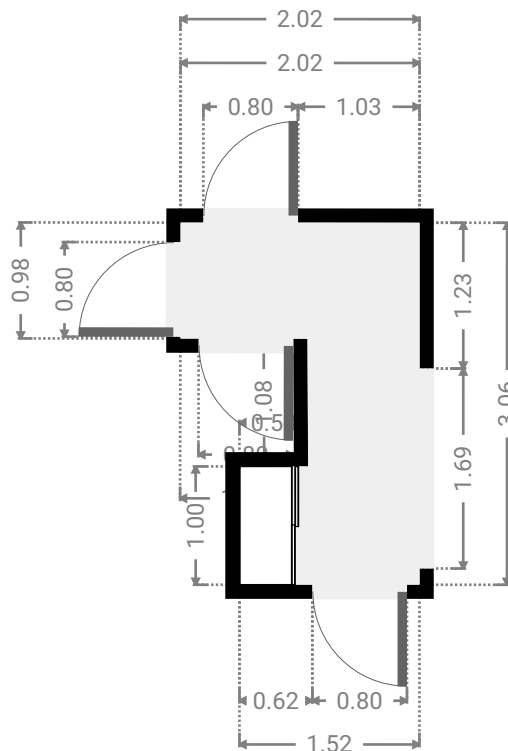
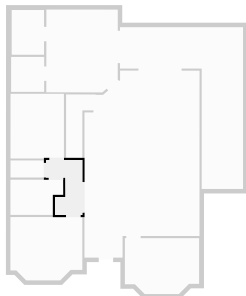

▼ **Living Room**  
1st Floor

WIDTH: 6.40 m • LENGTH: 10.40 m  
AREA: 58.56 m<sup>2</sup> • PERIMETER: 33.09 m

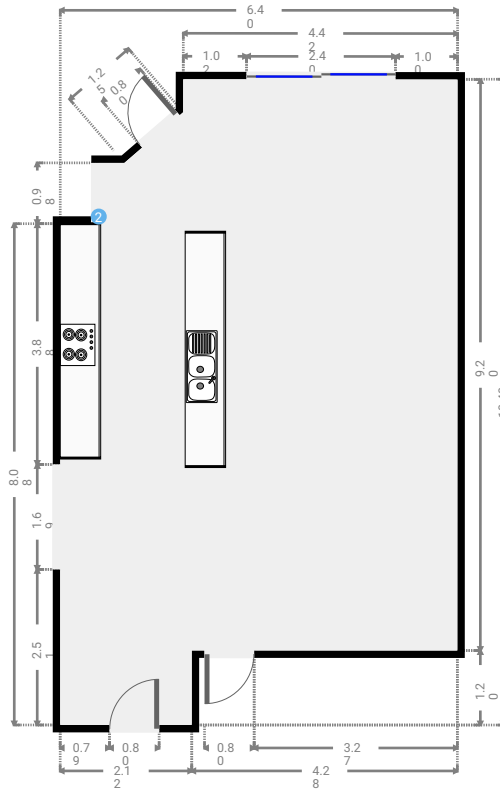
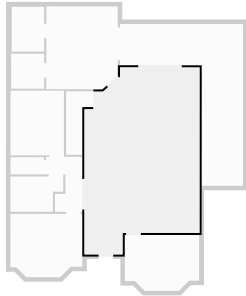

▼ **Other**  
1st Floor

WIDTH: 6.85 m • LENGTH: 9.00 m  
AREA: 31.16 m<sup>2</sup> • PERIMETER: 31.69 m

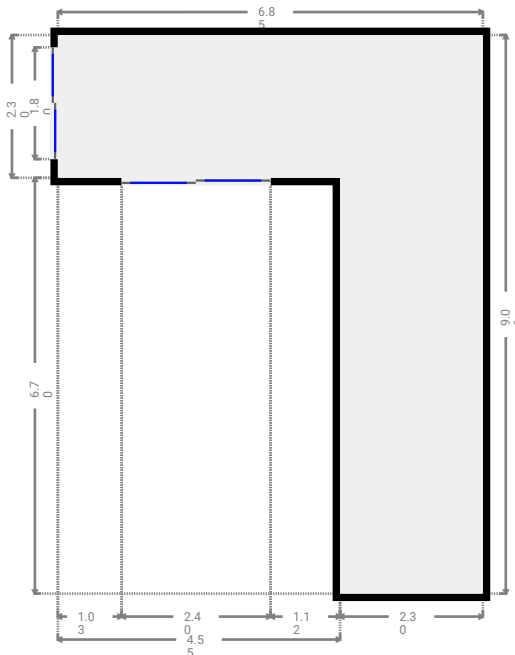
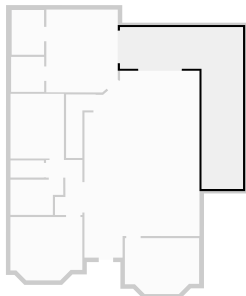

FLOORS: 2

▼ Stairway  
1st Floor

WIDTH: 1.53 m • LENGTH: 3.54 m  
AREA: 3.75 m<sup>2</sup> • PERIMETER: 10.12 m

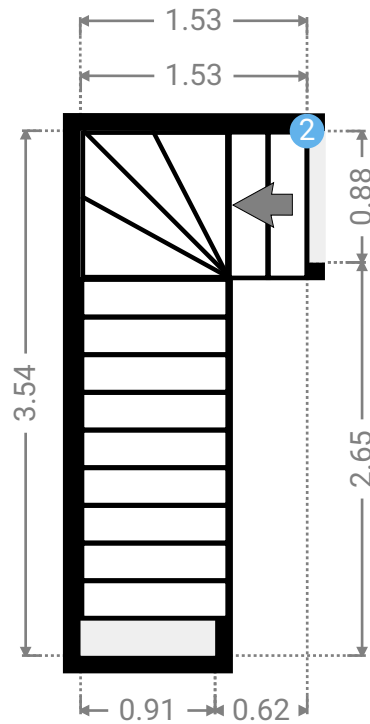
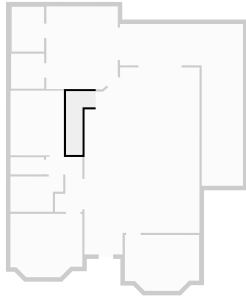

▼ Stairway/1st Floor

2 OPENING

Height  
0.00 m



▼ Toilet  
1st Floor

WIDTH: 1.86 m • LENGTH: 0.95 m  
AREA: 1.77 m<sup>2</sup> • PERIMETER: 5.62 m

