

11 Fenwick Street

Prepared by
11 Fenwick Street

Created on
2021-08-11

Floors
1

▼ Ground Floor

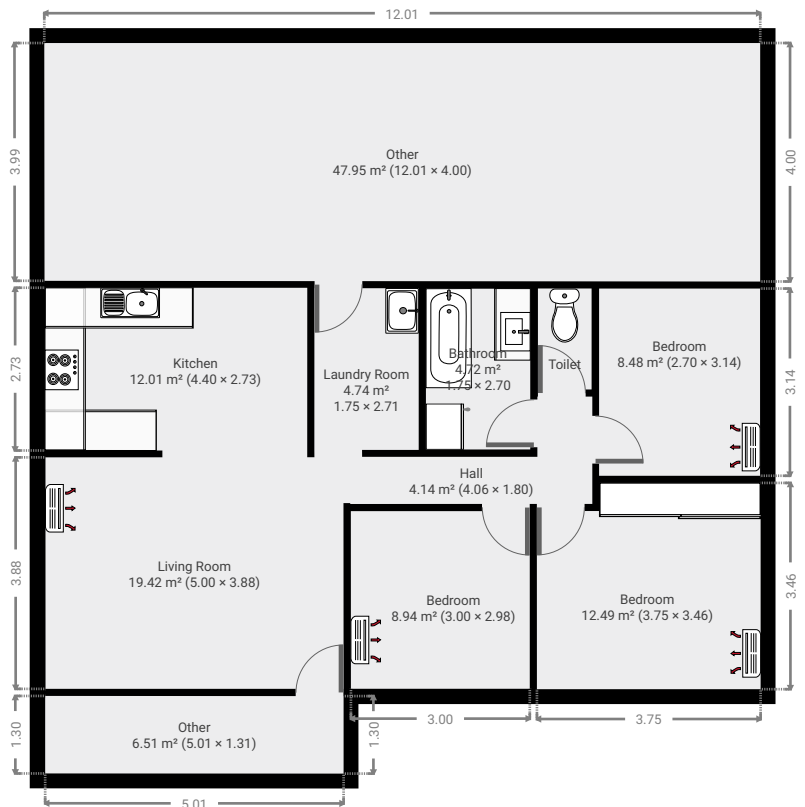
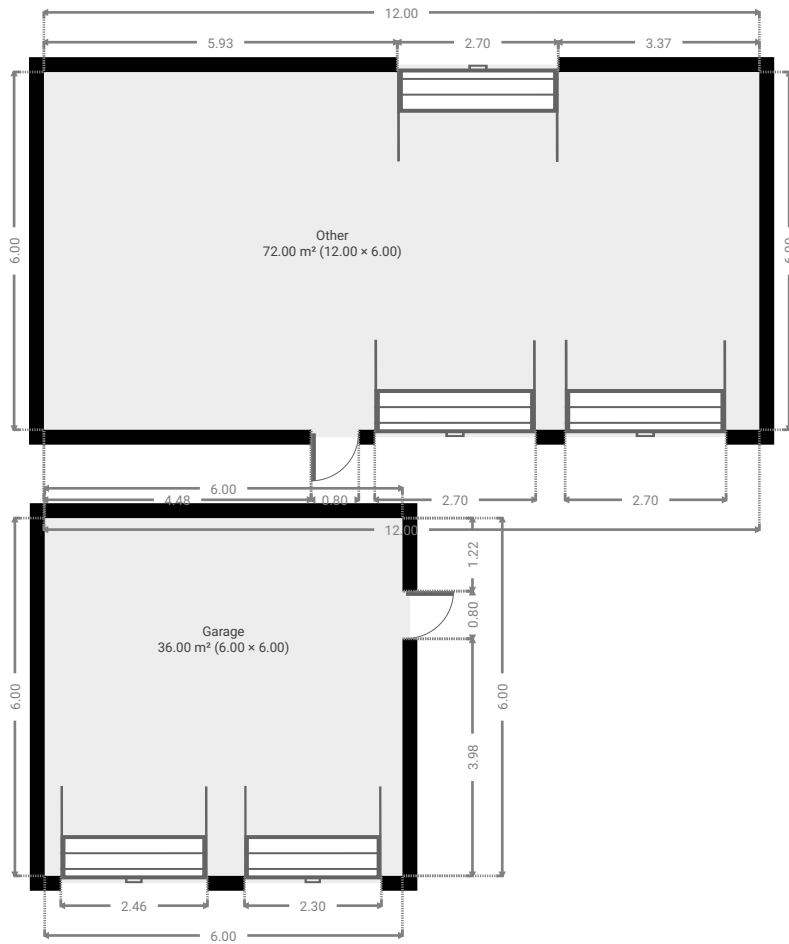

▼ Living Room
Ground Floor

WIDTH: 5.00 m • LENGTH: 3.88 m
AREA: 19.42 m² • PERIMETER: 17.77 m

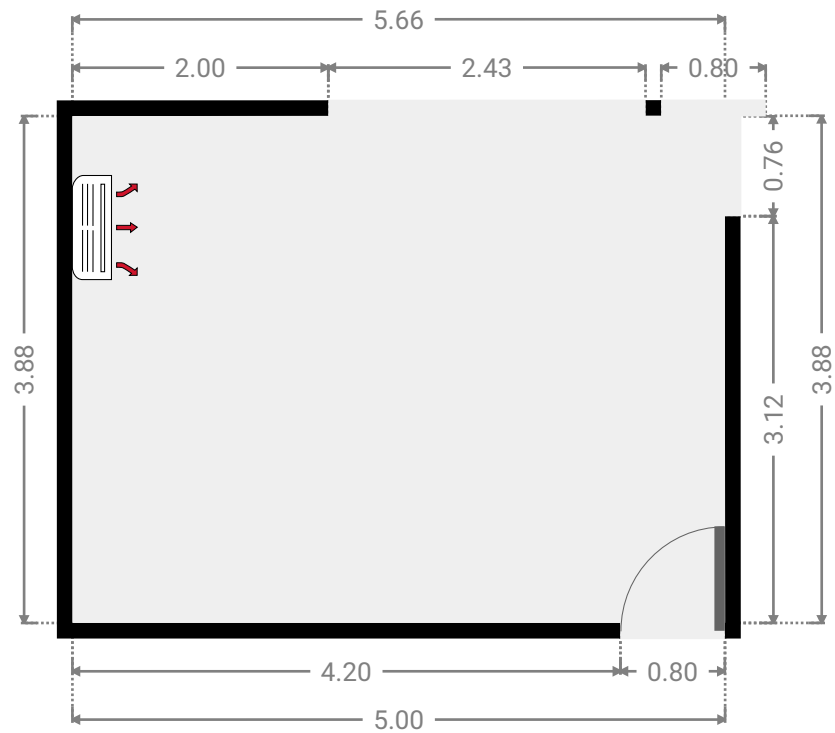
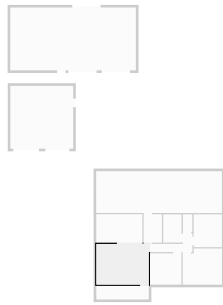

▼ Kitchen
Ground Floor

WIDTH: 4.40 m • LENGTH: 2.73 m
AREA: 12.01 m² • PERIMETER: 14.26 m

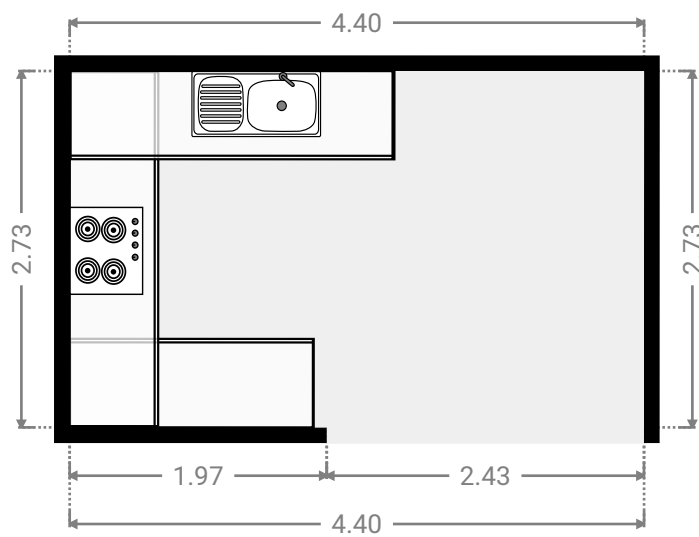
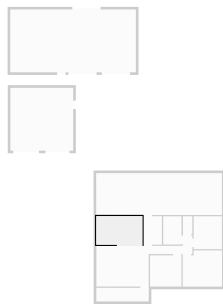

▼ Laundry Room
Ground Floor

WIDTH: 1.75 m • LENGTH: 2.71 m
AREA: 4.74 m² • PERIMETER: 8.92 m

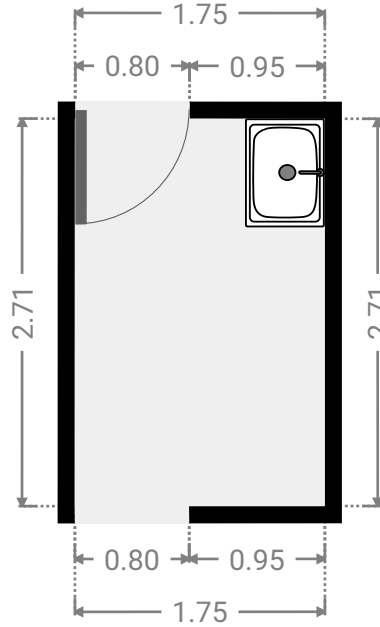
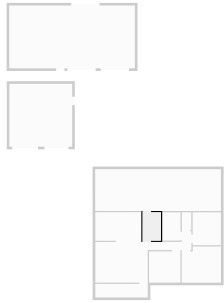

▼ Hall
Ground Floor

WIDTH: 4.06 m • LENGTH: 1.80 m
AREA: 4.14 m² • PERIMETER: 11.72 m

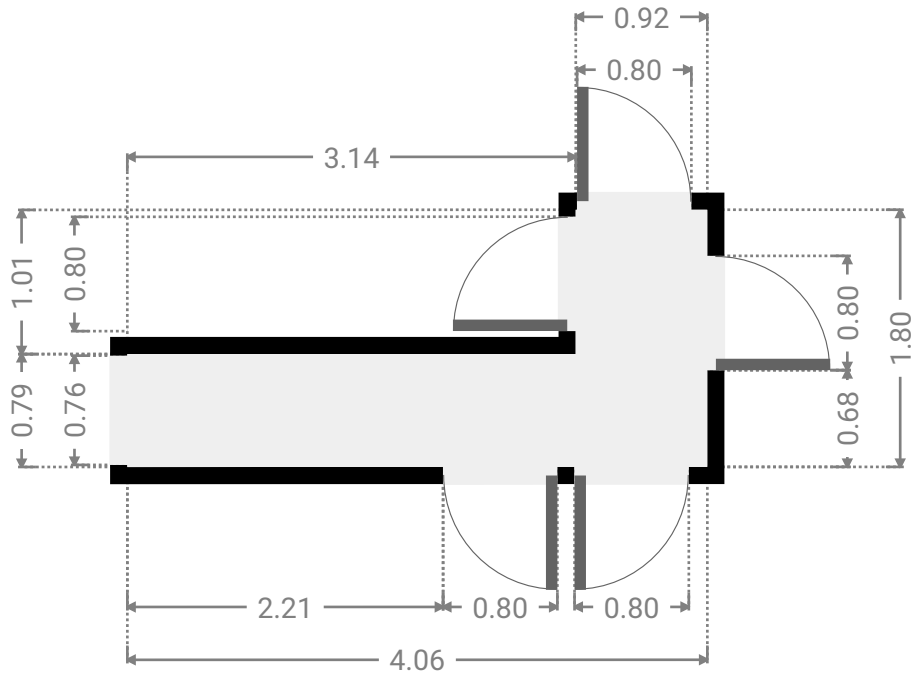
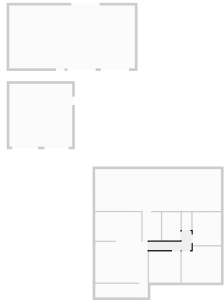

▼ **Bedroom**
Ground Floor

WIDTH: 3.00 m • LENGTH: 2.98 m
AREA: 8.94 m² • PERIMETER: 11.96 m

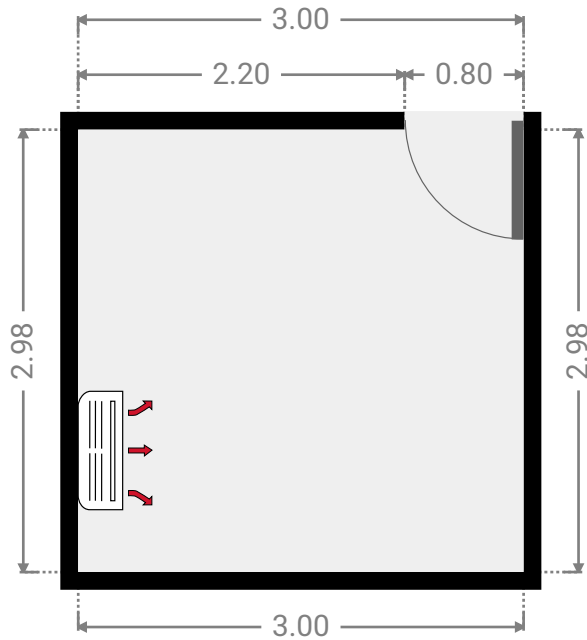
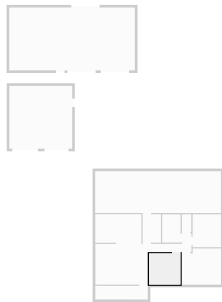

▼ **Bedroom**
Ground Floor

WIDTH: 3.75 m • LENGTH: 3.46 m
AREA: 12.49 m² • PERIMETER: 14.42 m

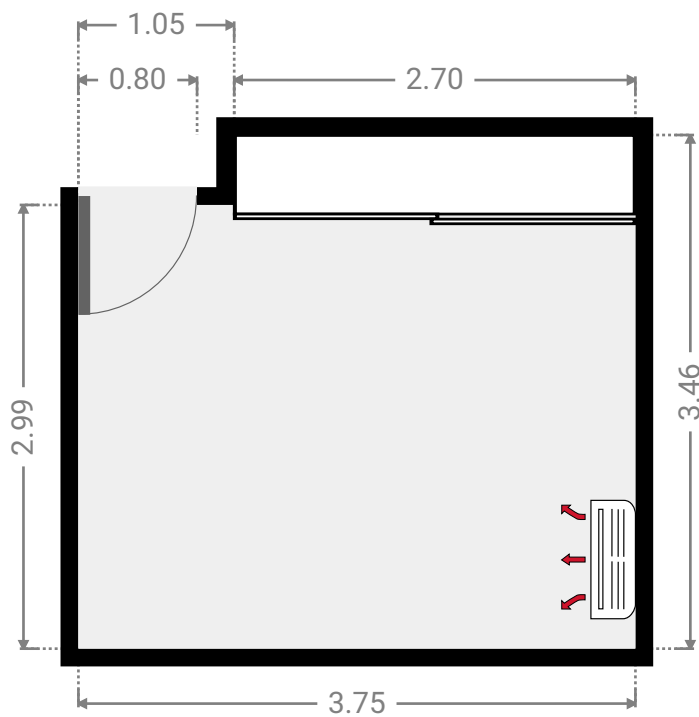
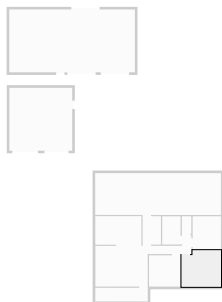

▼ **Bedroom**
Ground Floor

WIDTH: 2.70 m • LENGTH: 3.14 m
AREA: 8.48 m² • PERIMETER: 11.68 m

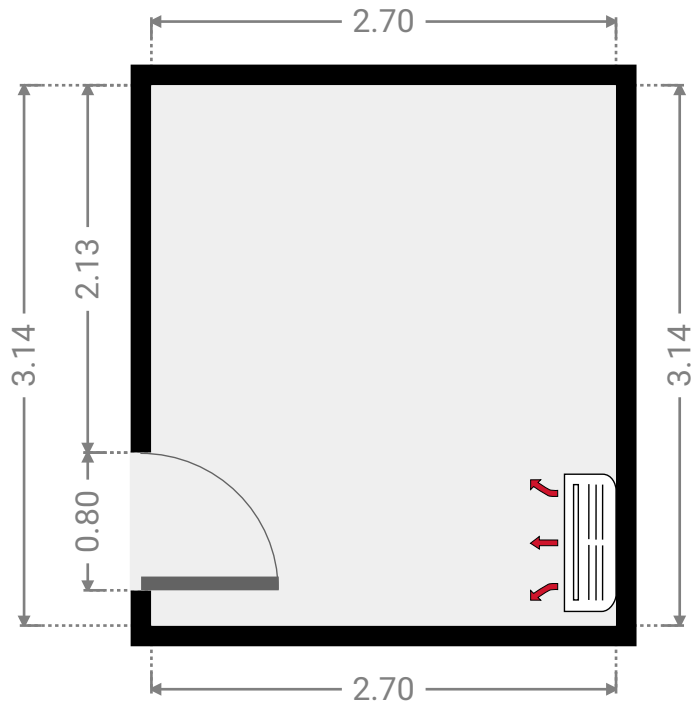
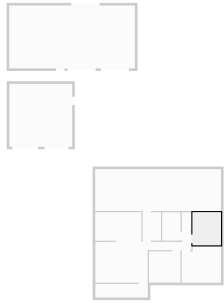

▼ **Toilet**
Ground Floor

WIDTH: 0.90 m • LENGTH: 1.69 m
AREA: 1.52 m² • PERIMETER: 5.19 m

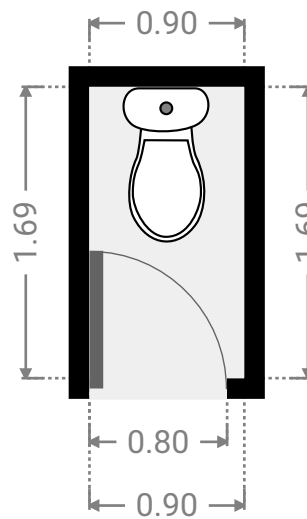
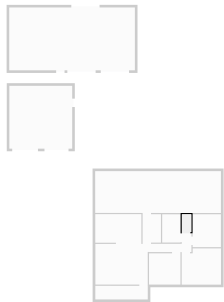

▼ **Bathroom**
Ground Floor

WIDTH: 1.75 m • LENGTH: 2.70 m
AREA: 4.72 m² • PERIMETER: 8.89 m

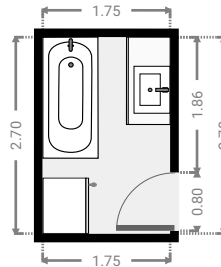
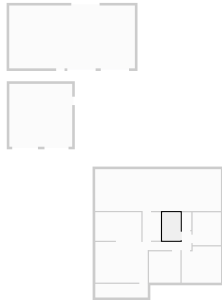

▼ **Other**
Ground Floor

WIDTH: 12.01 m • LENGTH: 4.00 m
AREA: 47.95 m² • PERIMETER: 32.00 m

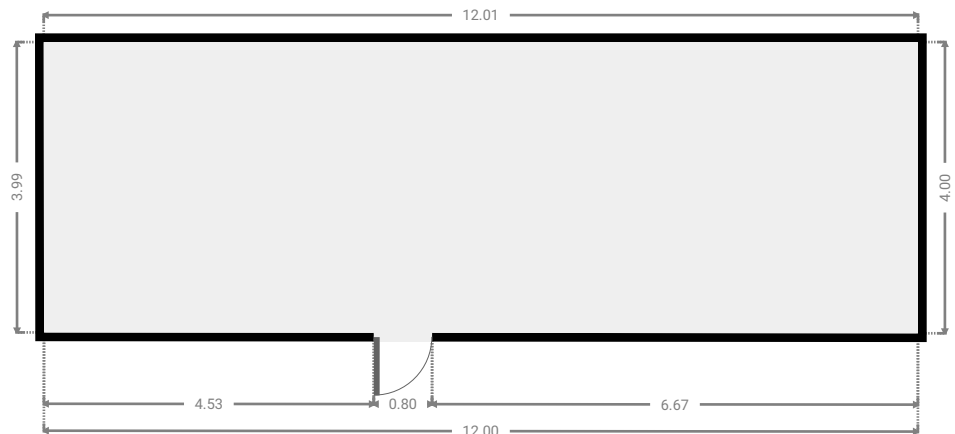
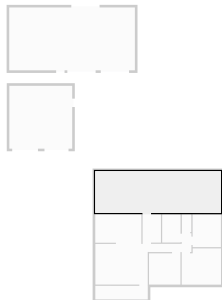

▼ **Garage**
Ground Floor

WIDTH: 6.00 m • LENGTH: 6.00 m
AREA: 36.00 m² • PERIMETER: 24.00 m

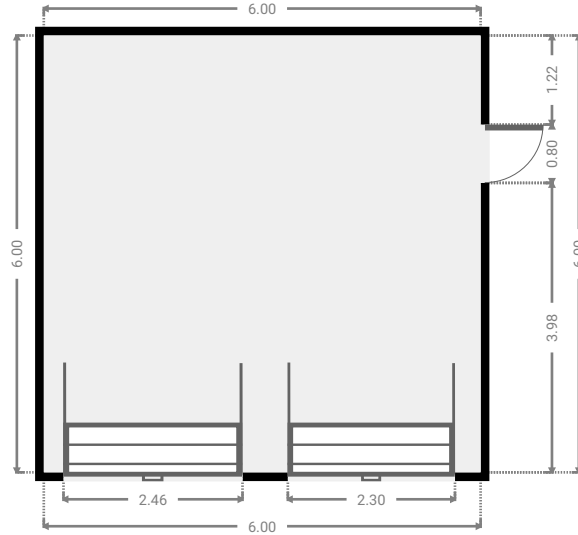
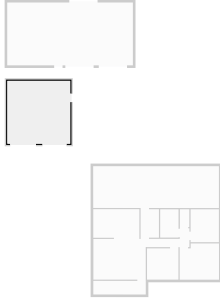

▼ **Other**
Ground Floor

WIDTH: 12.00 m • LENGTH: 6.00 m
AREA: 72.00 m² • PERIMETER: 36.00 m

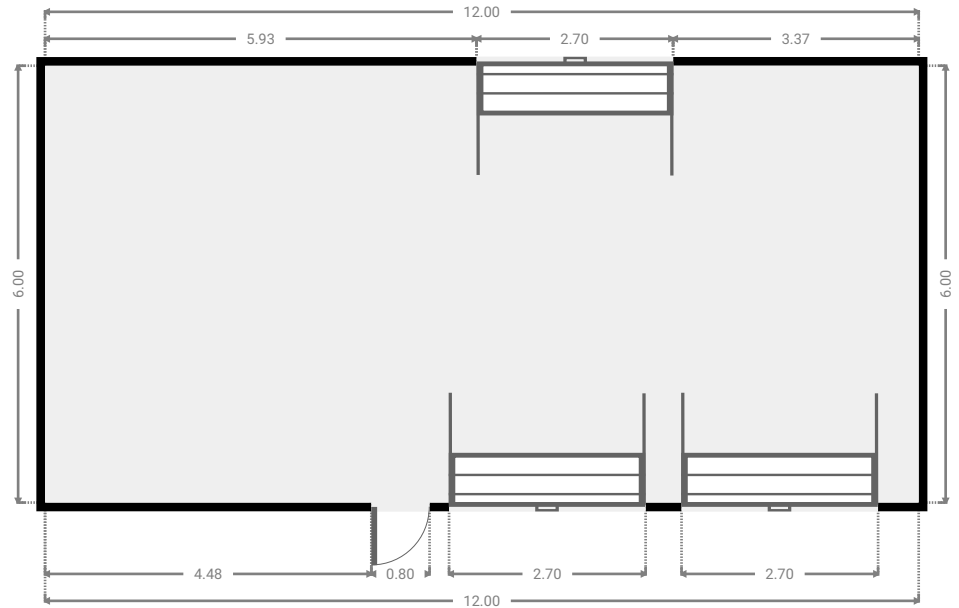
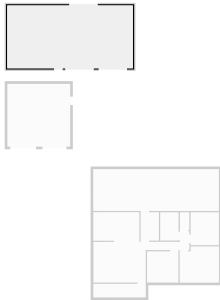

▼ Other
Ground Floor

WIDTH: 5.01 m • LENGTH: 1.31 m
AREA: 6.51 m² • PERIMETER: 12.61 m

