

11 Byrne Street

SUBMITTED BY
Ray White Rockhampton Casey
stockers@cqoz.com

CREATED ON
2022-03-29

Floors
2

▼ Ground Floor

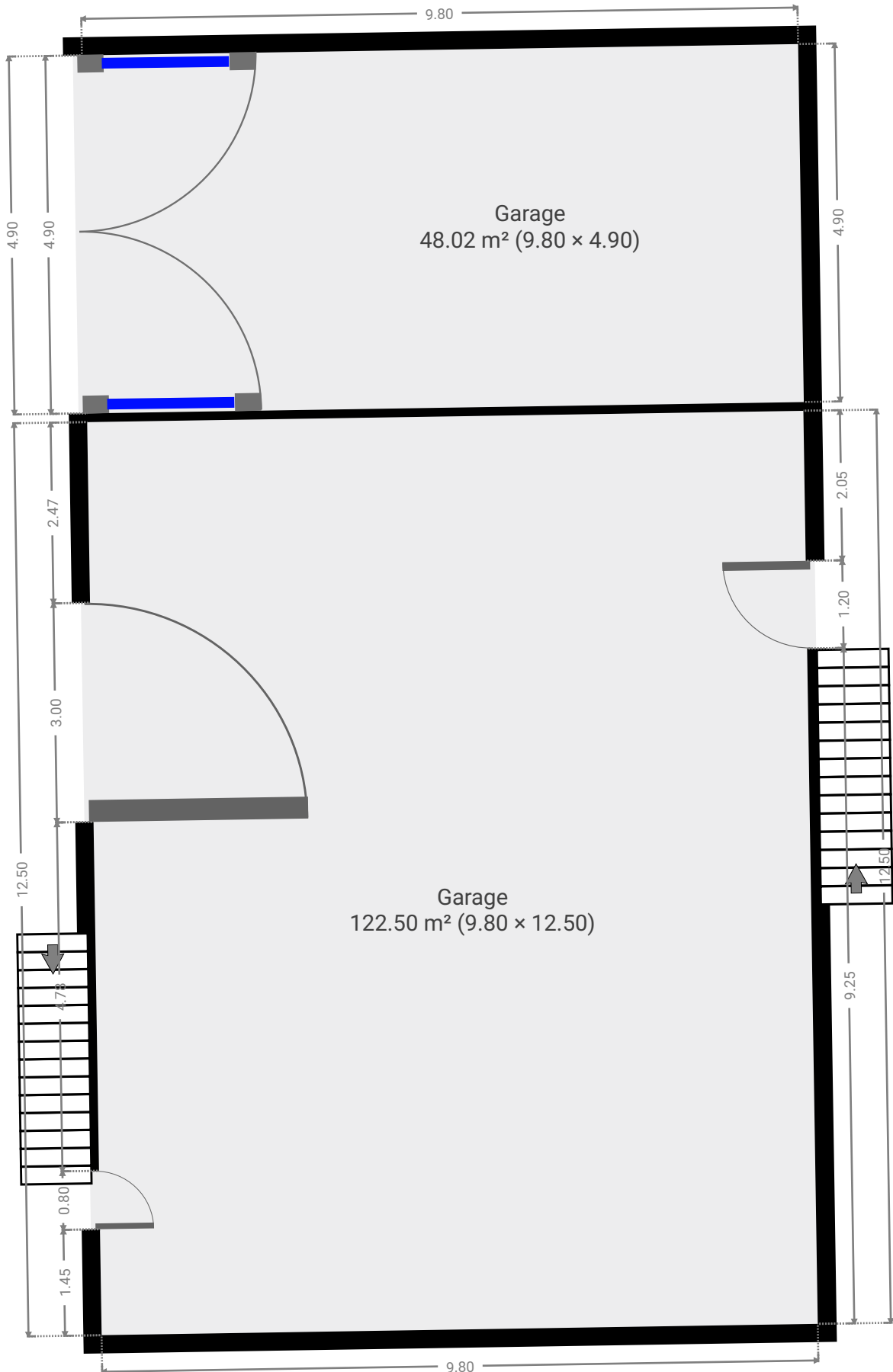

▼ **Garage**
Ground Floor

WIDTH: 4.90 m • LENGTH: 9.80 m
AREA: 48.02 m² • PERIMETER: 29.40 m

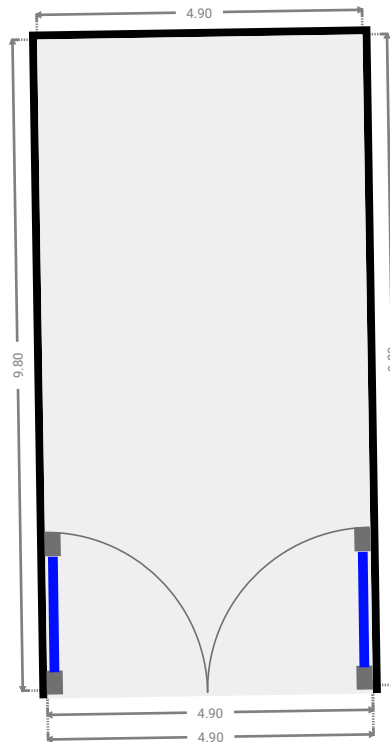
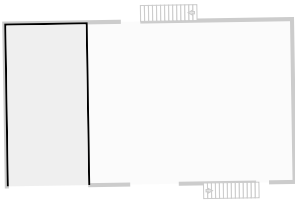

▼ **Garage**
Ground Floor

WIDTH: 12.50 m • LENGTH: 9.80 m
AREA: 122.50 m² • PERIMETER: 44.60 m

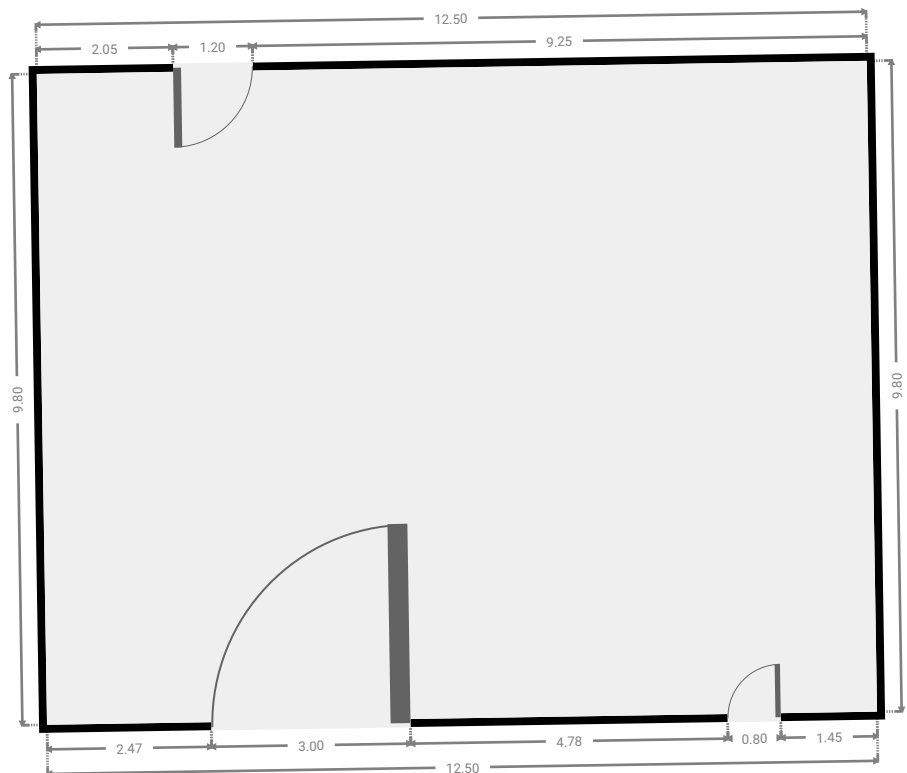
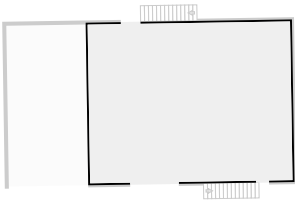

▼ 1st Floor



▼ **Living Room**
1st Floor

WIDTH: 2.56 m • LENGTH: 2.40 m
AREA: 6.14 m² • PERIMETER: 9.92 m

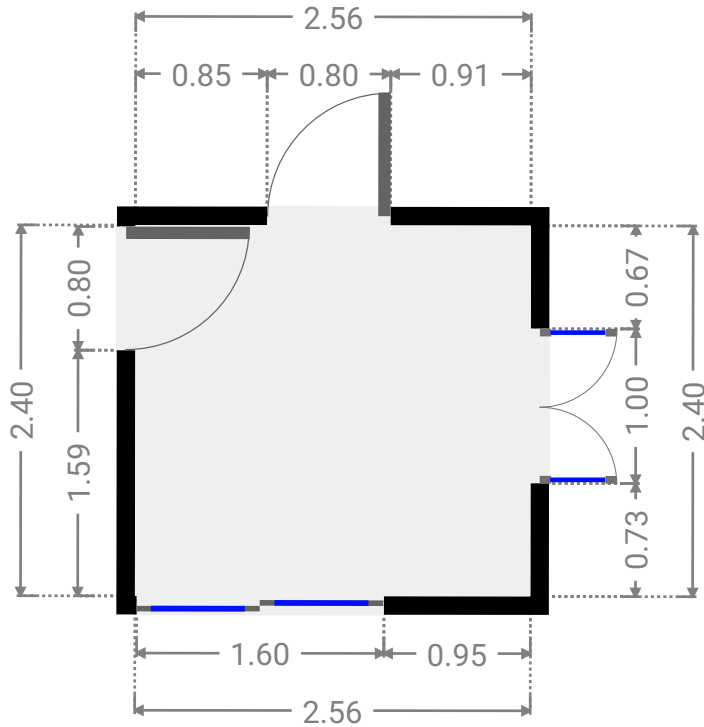
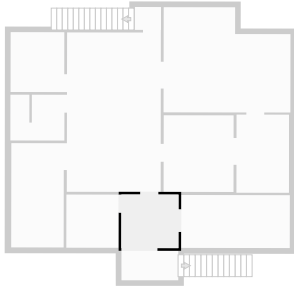

▼ **Study**
1st Floor

WIDTH: 2.35 m • LENGTH: 2.38 m
AREA: 5.59 m² • PERIMETER: 9.46 m

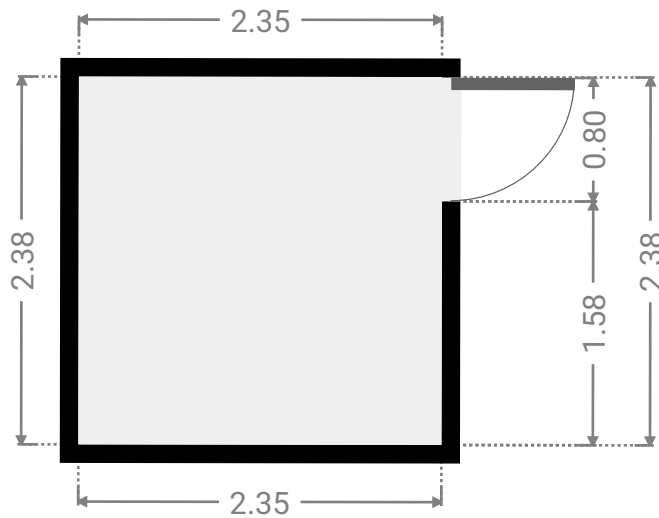
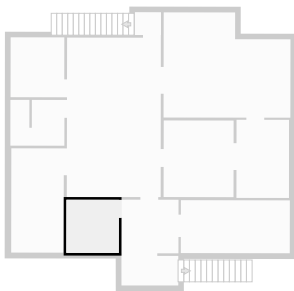

▼ Bedroom
1st Floor

WIDTH: 4.88 m • LENGTH: 2.37 m
AREA: 11.56 m² • PERIMETER: 14.50 m

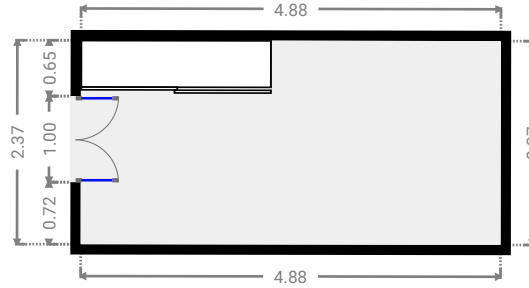
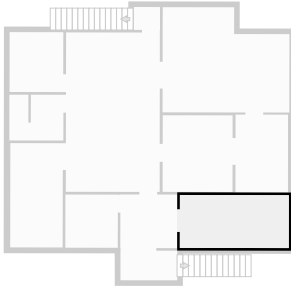

▼ Living Room
1st Floor

WIDTH: 4.21 m • LENGTH: 7.14 m
AREA: 30.01 m² • PERIMETER: 22.69 m

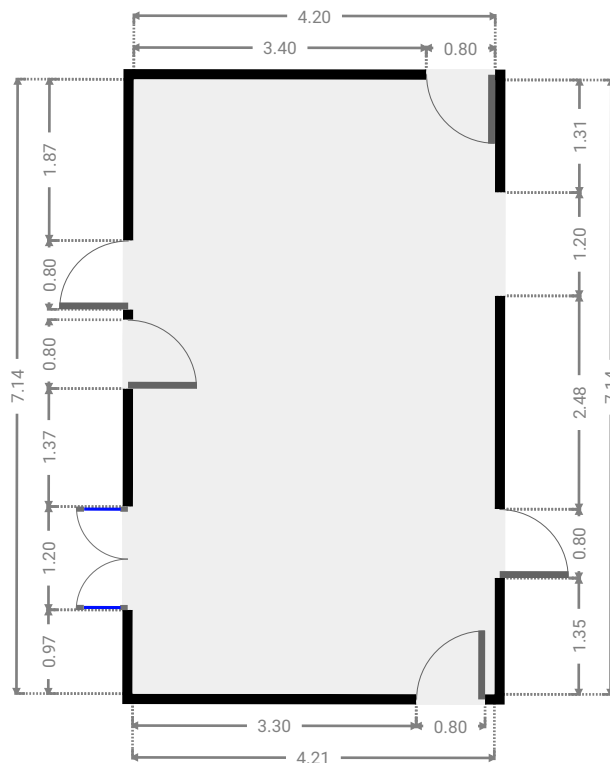
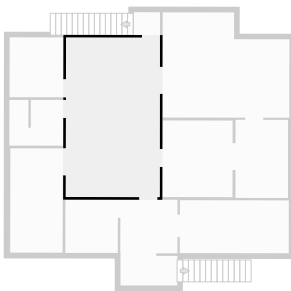

▼ Bedroom
1st Floor

WIDTH: 2.35 m • LENGTH: 4.67 m
AREA: 10.97 m² • PERIMETER: 14.04 m

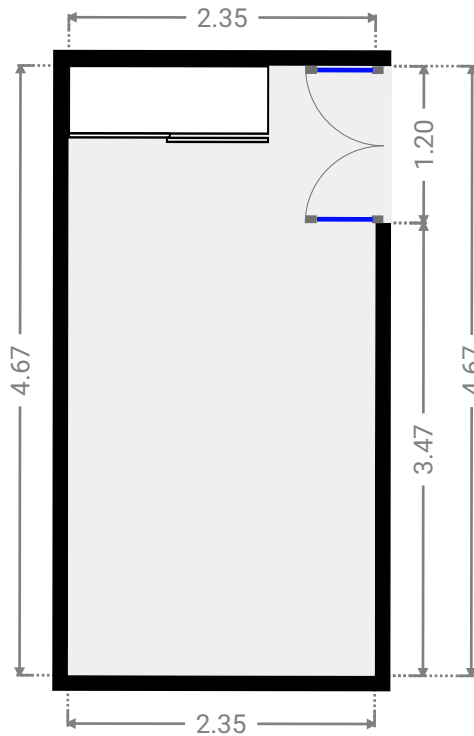
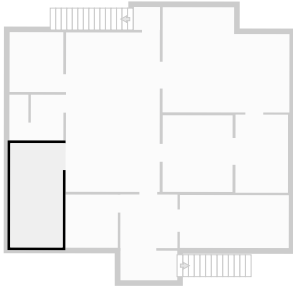

▼ Hall
1st Floor

WIDTH: 1.46 m • LENGTH: 2.05 m
AREA: 2.99 m² • PERIMETER: 7.02 m

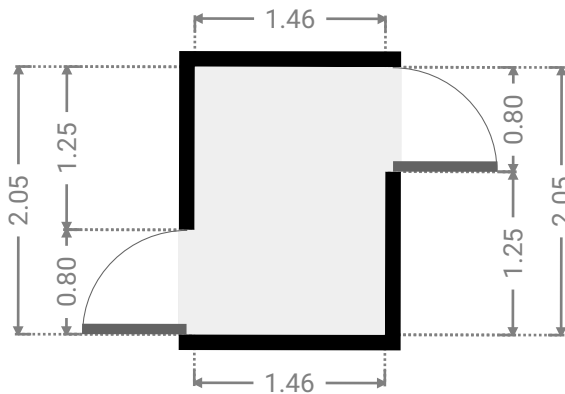
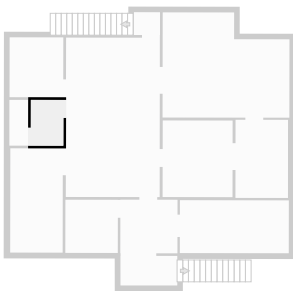

▼ **Toilet**
1st Floor

WIDTH: 0.85 m • LENGTH: 2.05 m
AREA: 1.74 m² • PERIMETER: 5.80 m

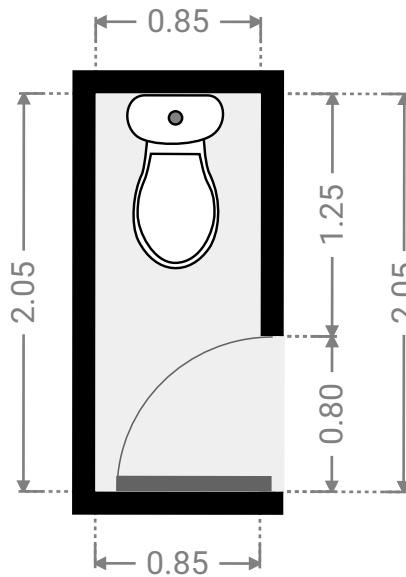
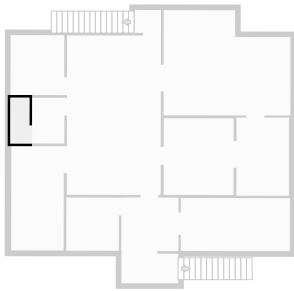

▼ **Bathroom**
1st Floor

WIDTH: 2.40 m • LENGTH: 2.68 m
AREA: 6.45 m² • PERIMETER: 10.17 m

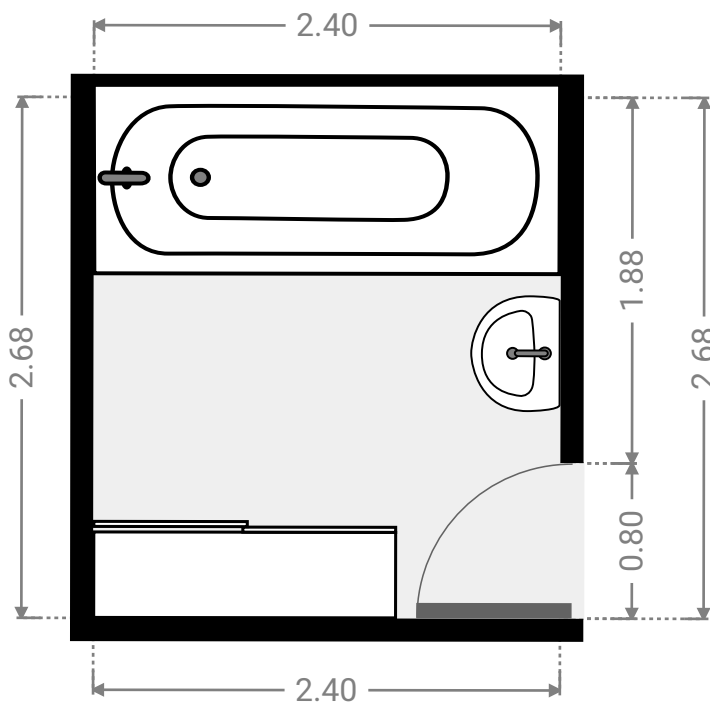
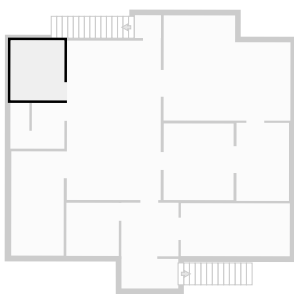

▼ **Kitchen**
1st Floor

WIDTH: 5.68 m • LENGTH: 4.71 m
AREA: 23.78 m² • PERIMETER: 20.78 m

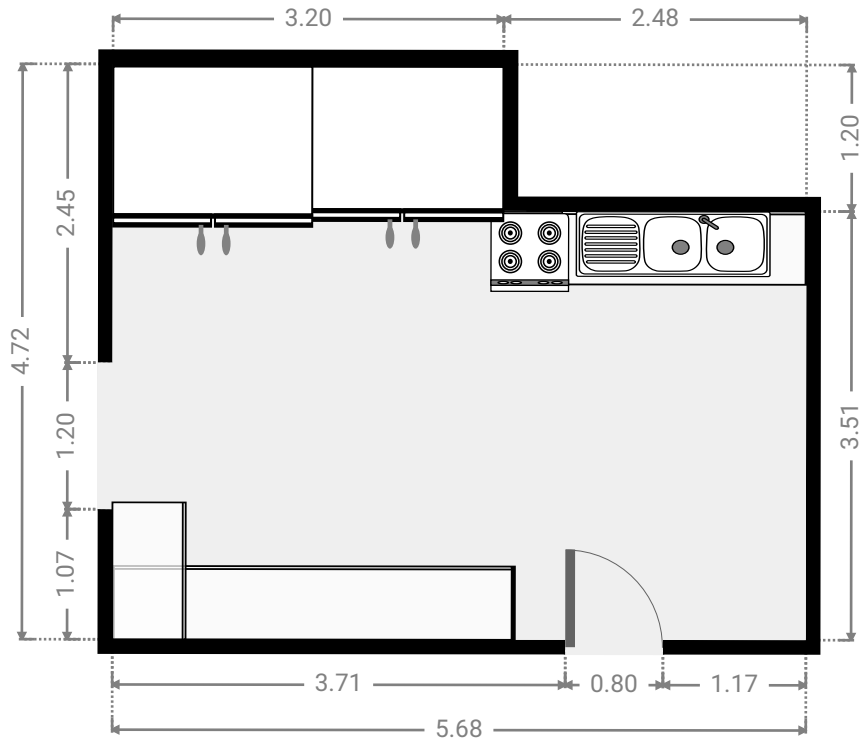
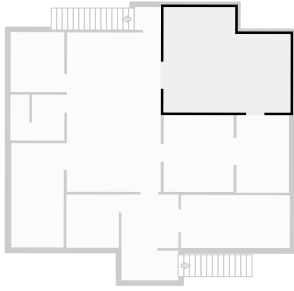

▼ **Bedroom**
1st Floor

WIDTH: 3.13 m • LENGTH: 3.43 m
AREA: 10.74 m² • PERIMETER: 13.12 m

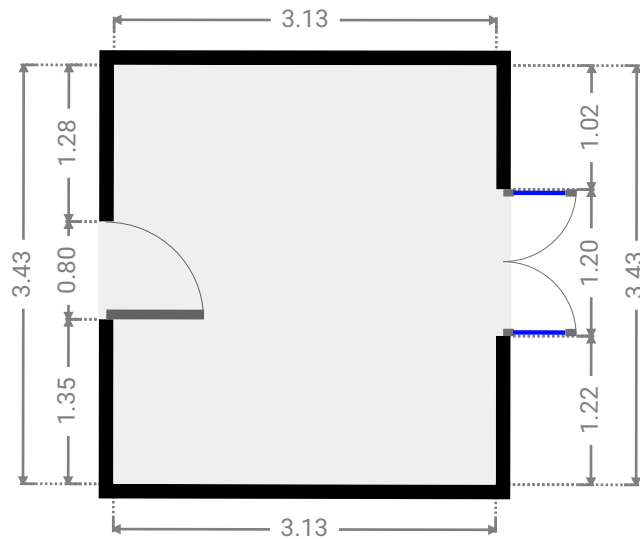
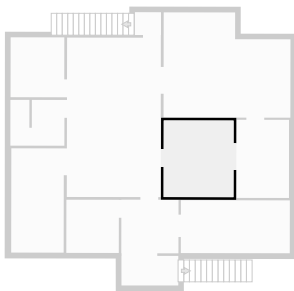

▼ **Closet**
1st Floor

WIDTH: 2.35 m • LENGTH: 3.50 m
AREA: 8.23 m² • PERIMETER: 11.70 m

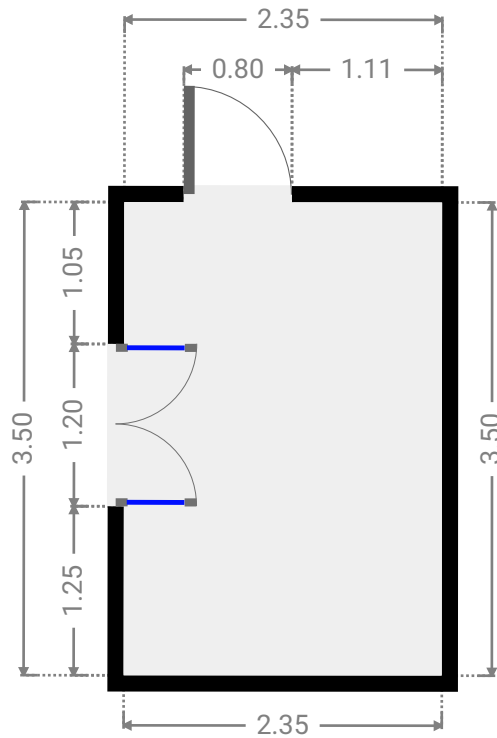
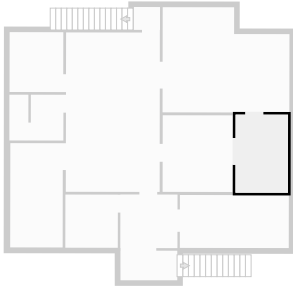

▼ **Other**
1st Floor

WIDTH: 1.17 m • LENGTH: 1.02 m
AREA: 1.20 m² • PERIMETER: 4.39 m

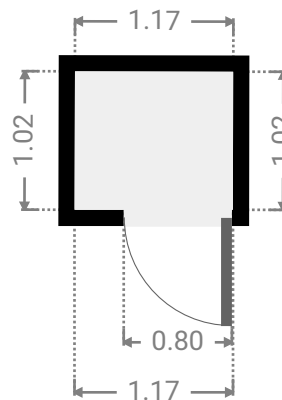
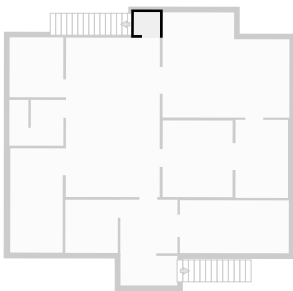

▼ Other
1st Floor

WIDTH: 2.55 m • LENGTH: 1.33 m
AREA: 3.37 m² • PERIMETER: 7.74 m

