

11 Ann STREET

SUBMITTED BY

Ray White Rockhampton Casey
stockers@cqoz.com

CREATED ON

2022-09-07

Floors

1

▼ Ground Floor

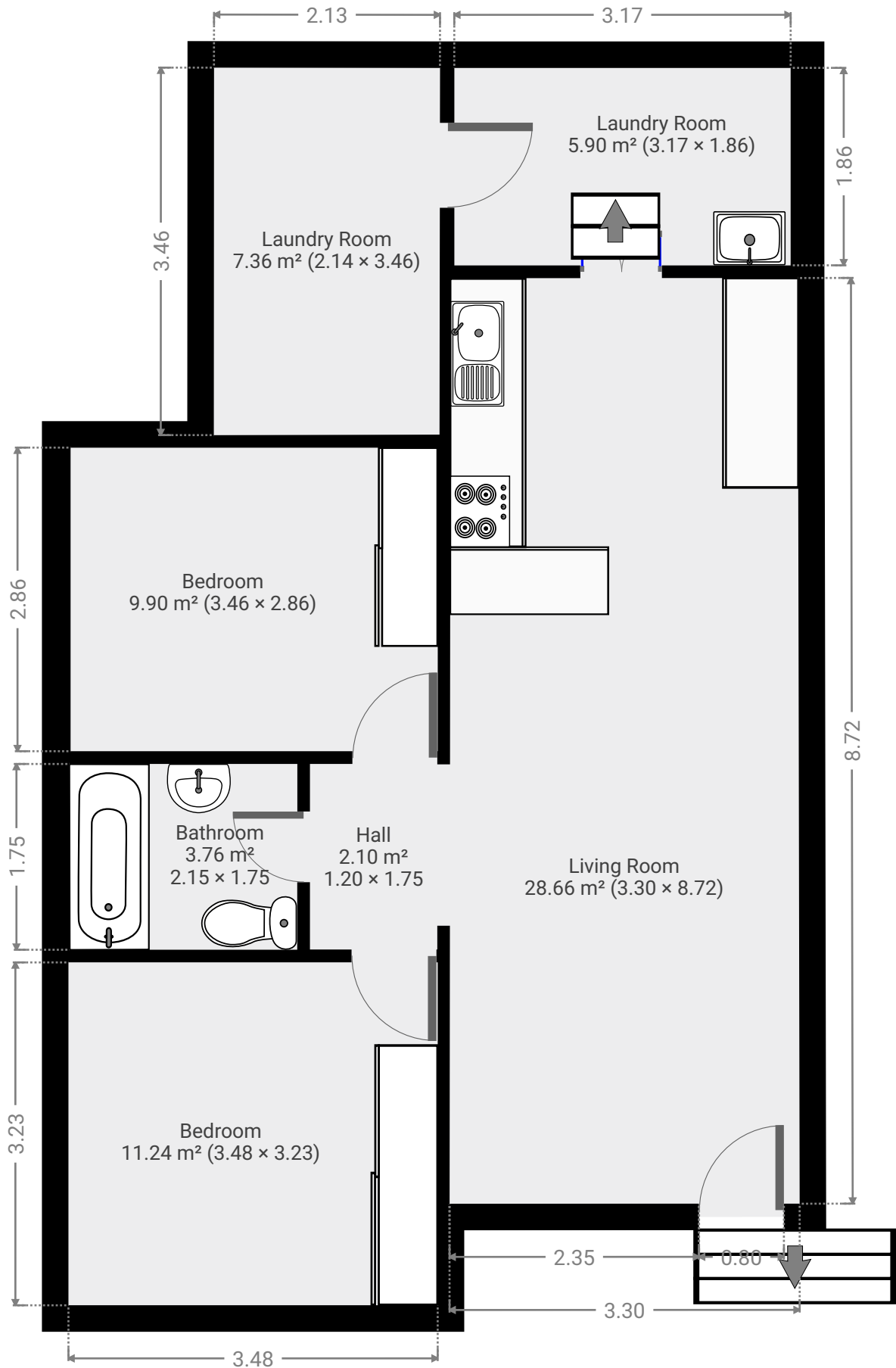

▼ **Bathroom**
Ground Floor

WIDTH: 2.15 m • LENGTH: 1.75 m
AREA: 3.76 m² • PERIMETER: 7.79 m

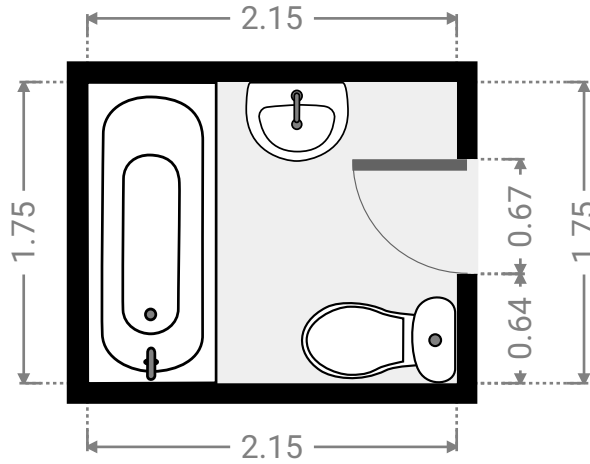
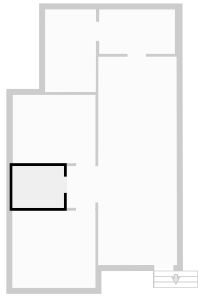

▼ **Bedroom**
Ground Floor

WIDTH: 3.46 m • LENGTH: 2.86 m
AREA: 9.90 m² • PERIMETER: 12.64 m

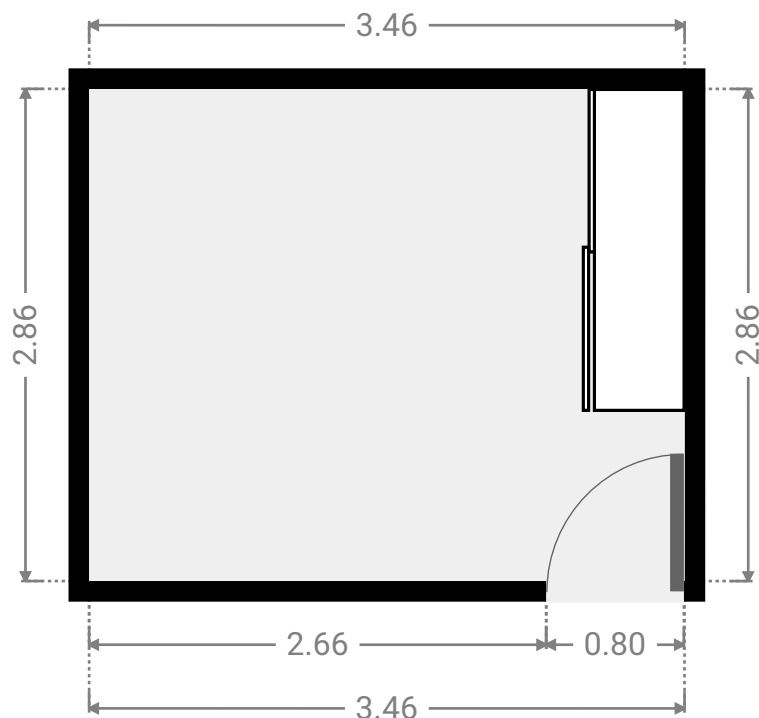
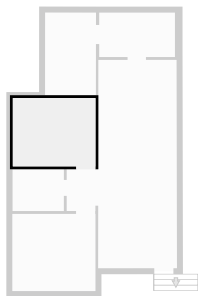

▼ **Bedroom**
Ground Floor

WIDTH: 3.48 m • LENGTH: 3.23 m
AREA: 11.24 m² • PERIMETER: 13.42 m

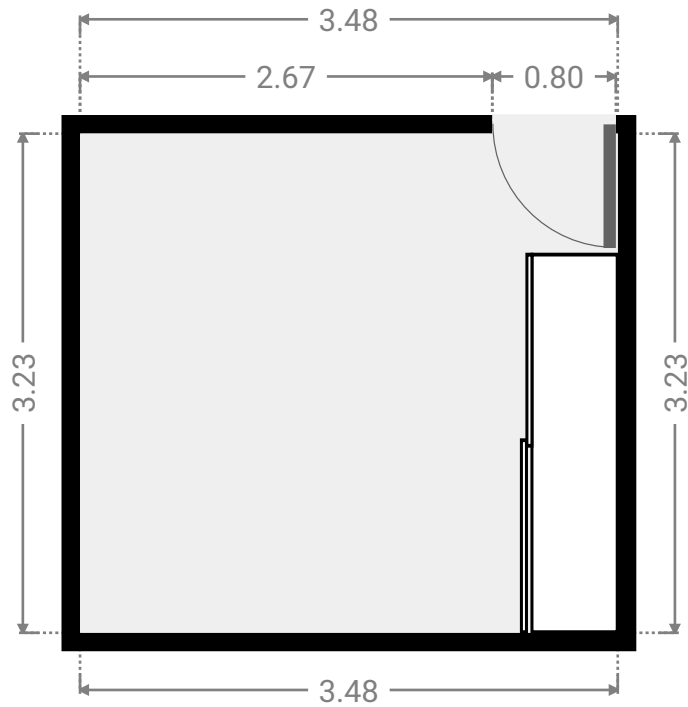
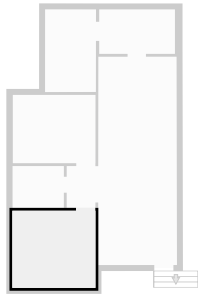

▼ **Hall**
Ground Floor

WIDTH: 1.20 m • LENGTH: 1.75 m
AREA: 2.10 m² • PERIMETER: 5.90 m

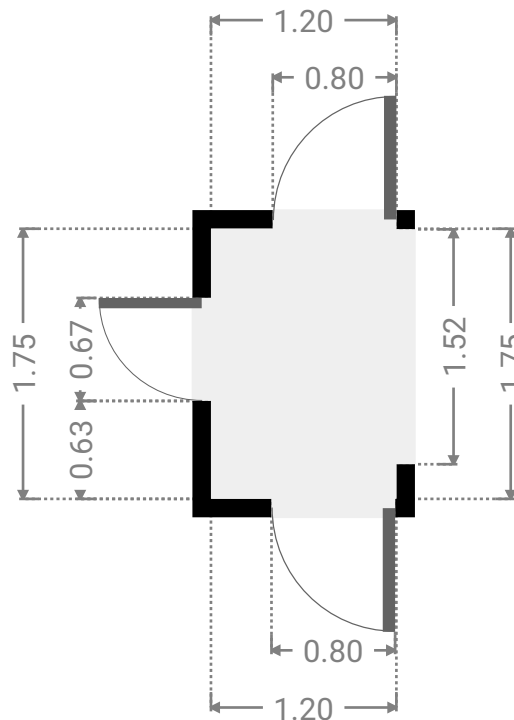
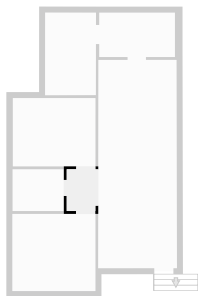

▼ **Laundry Room**
Ground Floor

WIDTH: 3.17 m • LENGTH: 1.86 m
AREA: 5.90 m² • PERIMETER: 10.06 m

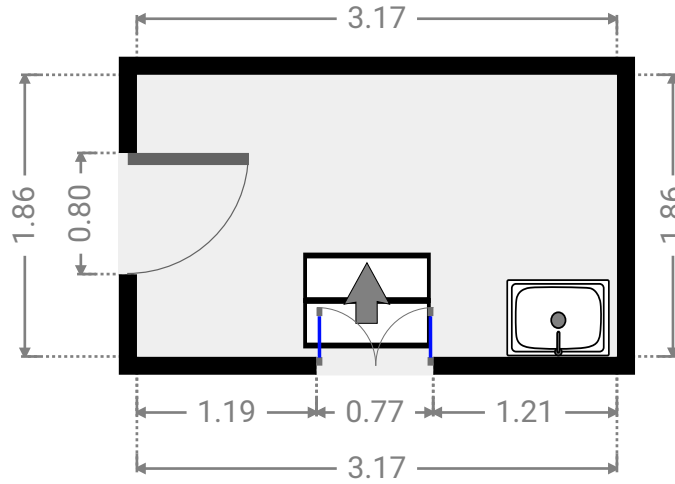
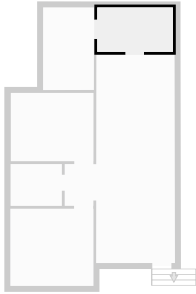

▼ **Laundry Room**
Ground Floor

WIDTH: 2.14 m • LENGTH: 3.46 m
AREA: 7.36 m² • PERIMETER: 11.17 m

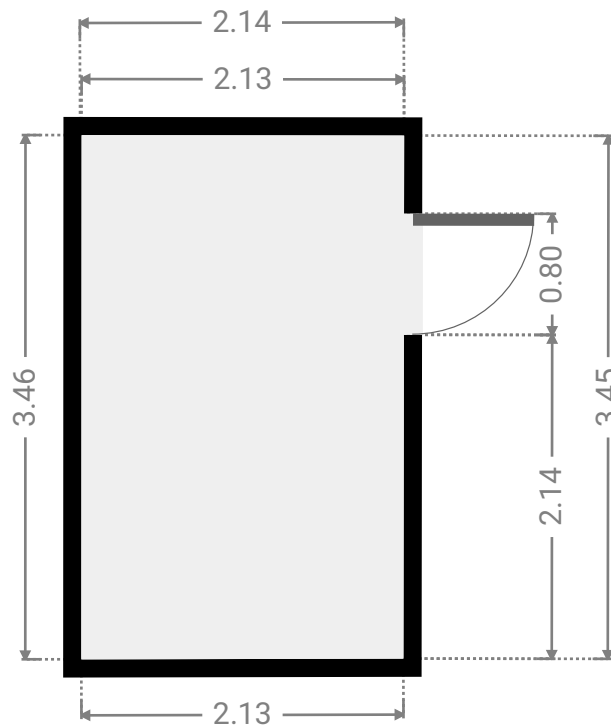
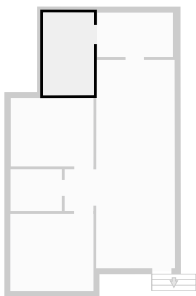

▼ Living Room
Ground Floor

WIDTH: 3.30 m • LENGTH: 8.72 m
AREA: 28.66 m² • PERIMETER: 24.01 m

