

108A Stanley Street

SUBMITTED BY

Ray White Rockhampton Casey
stockers@cqoz.com

CREATED ON

2022-06-13

Floors

2

▼ Ground Floor

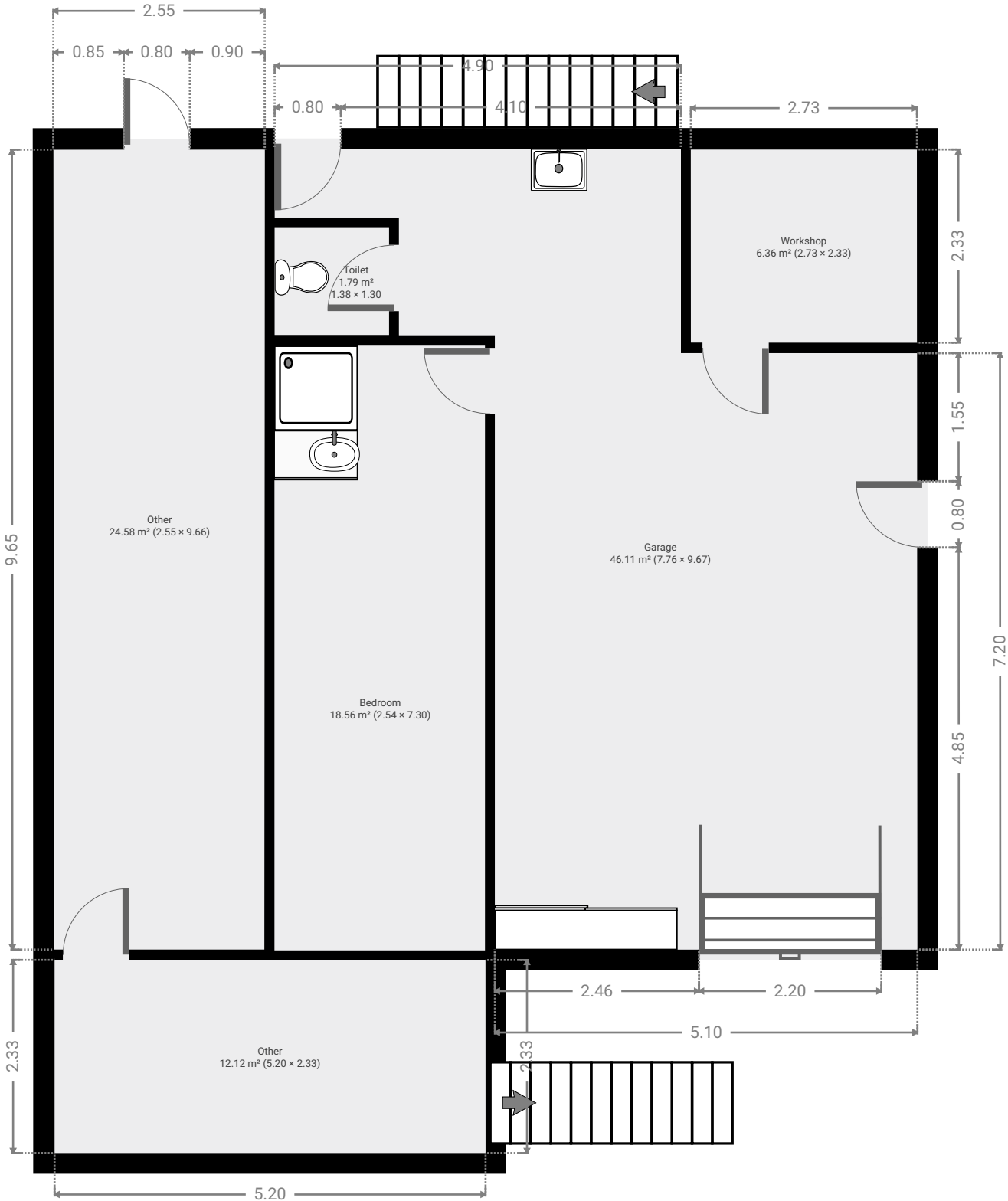

▼ **Bedroom**
Ground Floor

WIDTH: 2.53 m • LENGTH: 7.30 m
AREA: 18.56 m² • PERIMETER: 19.68 m

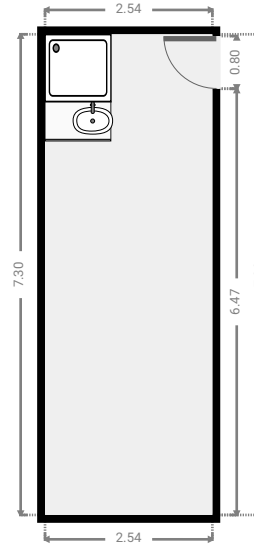
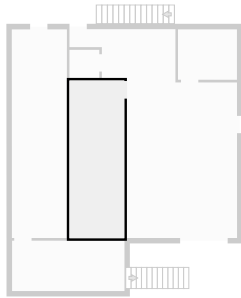

▼ **Garage**
Ground Floor

WIDTH: 7.76 m • LENGTH: 9.67 m
AREA: 46.11 m² • PERIMETER: 34.85 m

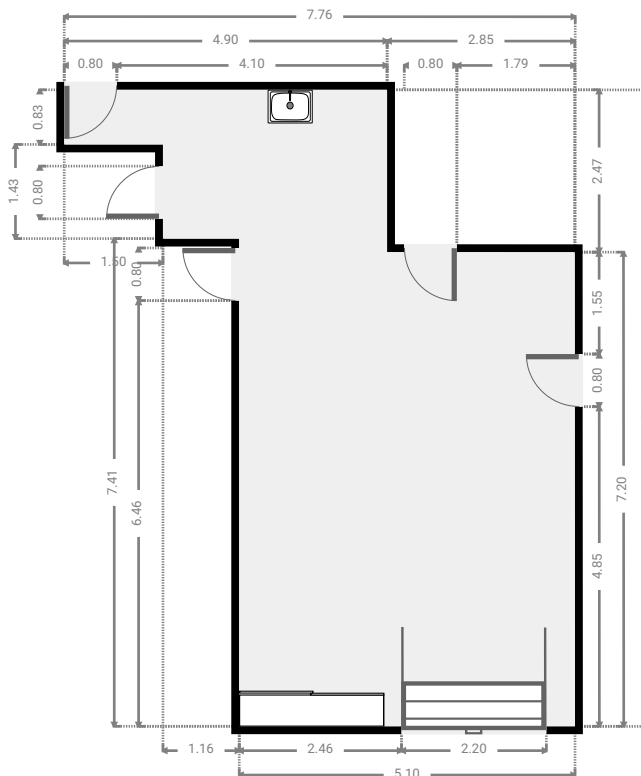
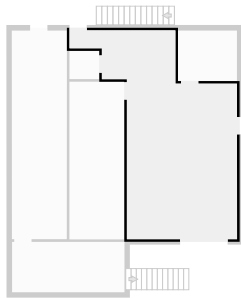

▼ **Other**
Ground Floor

WIDTH: 2.55 m • LENGTH: 9.66 m
AREA: 24.58 m² • PERIMETER: 24.40 m

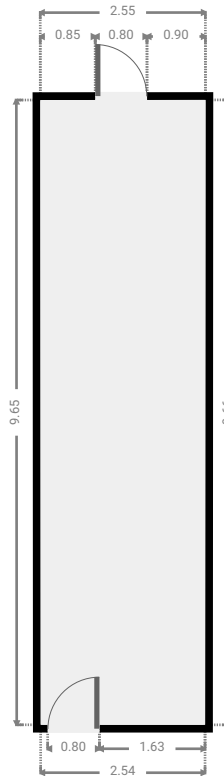
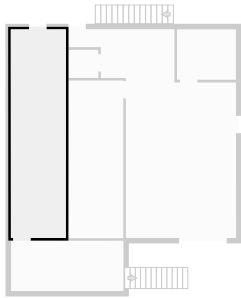

▼ **Other**
Ground Floor

WIDTH: 5.20 m • LENGTH: 2.33 m
AREA: 12.12 m² • PERIMETER: 15.07 m

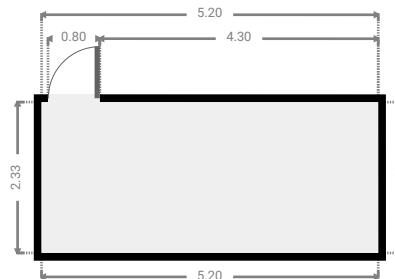
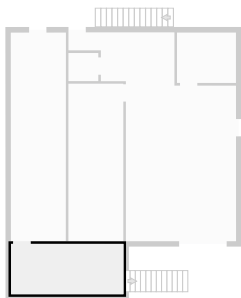

▼ **Toilet**
Ground Floor

WIDTH: 1.37 m • LENGTH: 1.31 m
AREA: 1.79 m² • PERIMETER: 5.36 m

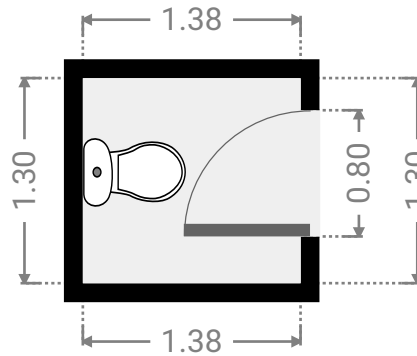
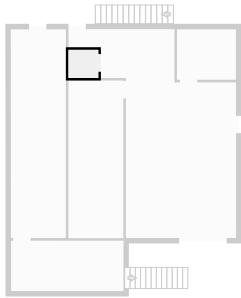

▼ **Workshop**
Ground Floor

WIDTH: 2.73 m • LENGTH: 2.23 m
AREA: 6.36 m² • PERIMETER: 10.12 m

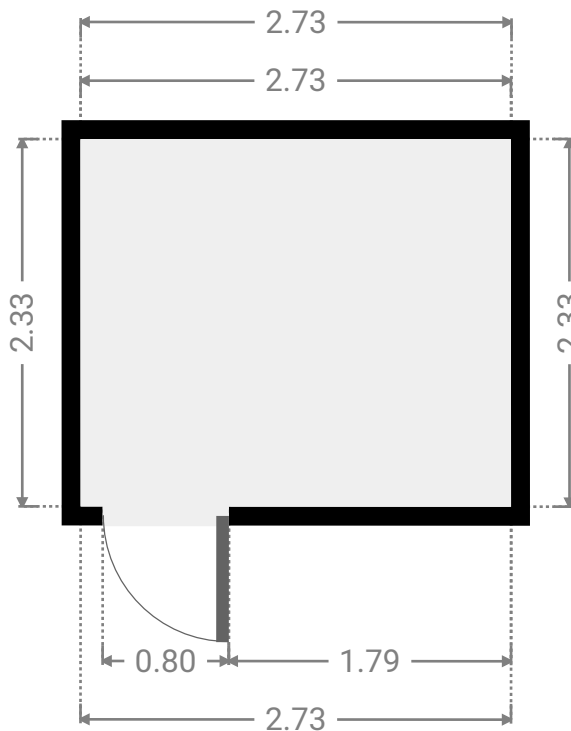
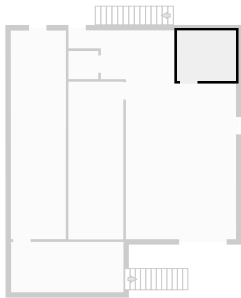

▼ 1st Floor

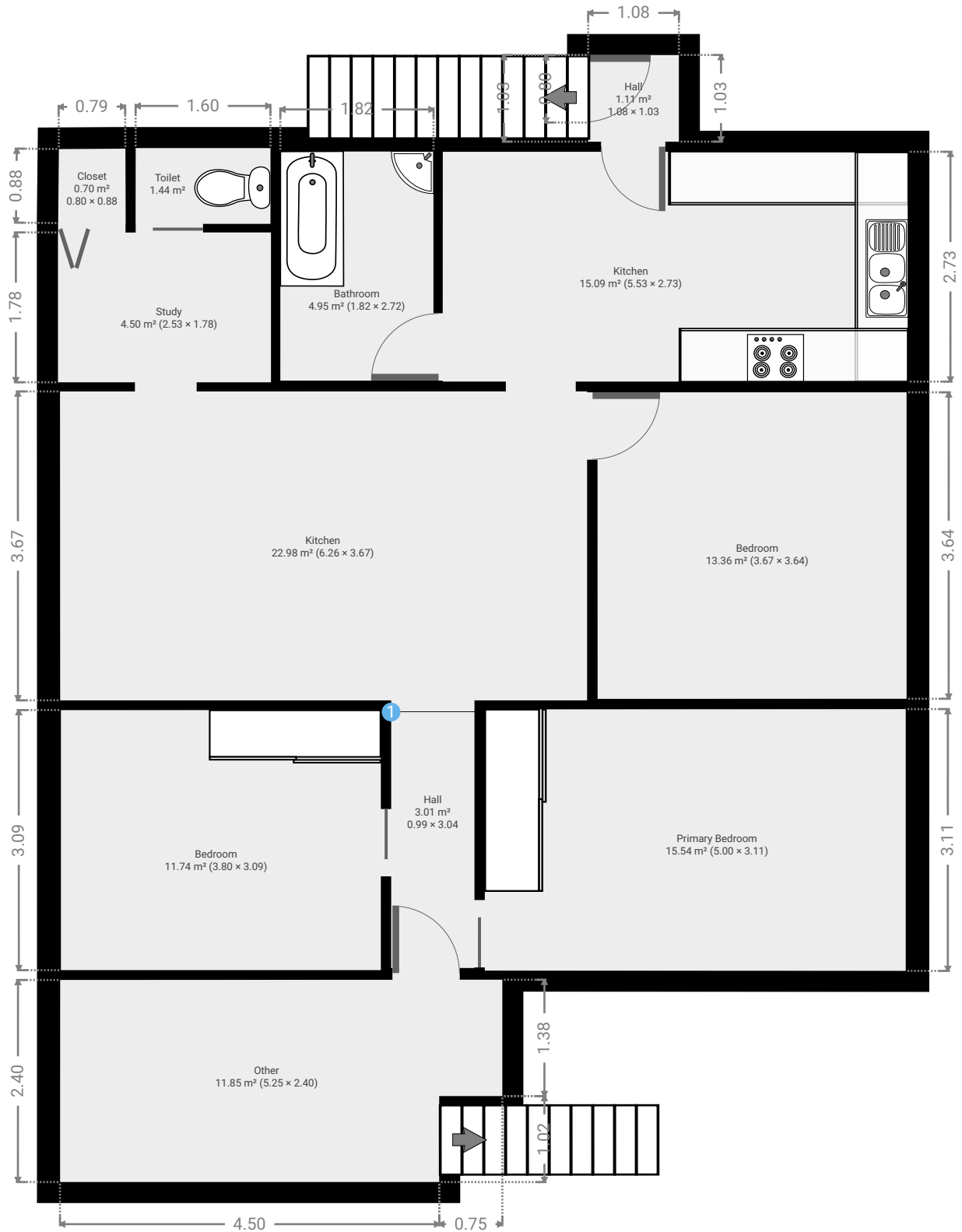

▼ **Bathroom**
1st Floor

WIDTH: 1.82 m • LENGTH: 2.72 m
AREA: 4.95 m² • PERIMETER: 9.08 m

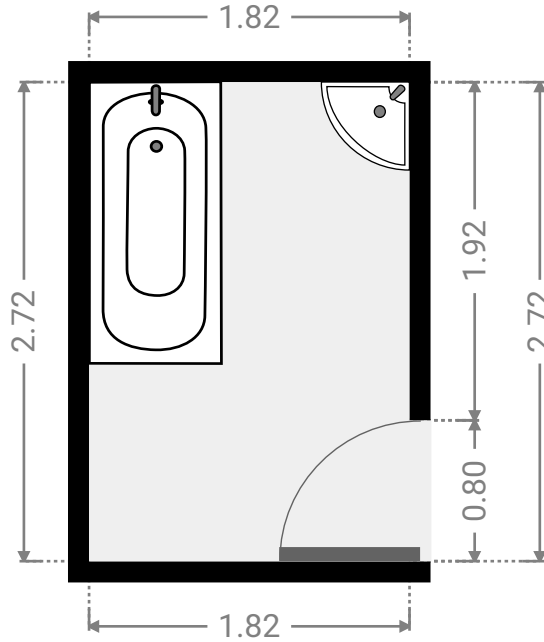
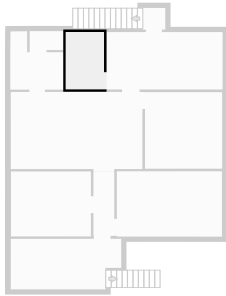

▼ **Bedroom**
1st Floor

WIDTH: 3.80 m • LENGTH: 3.09 m
AREA: 11.74 m² • PERIMETER: 13.78 m

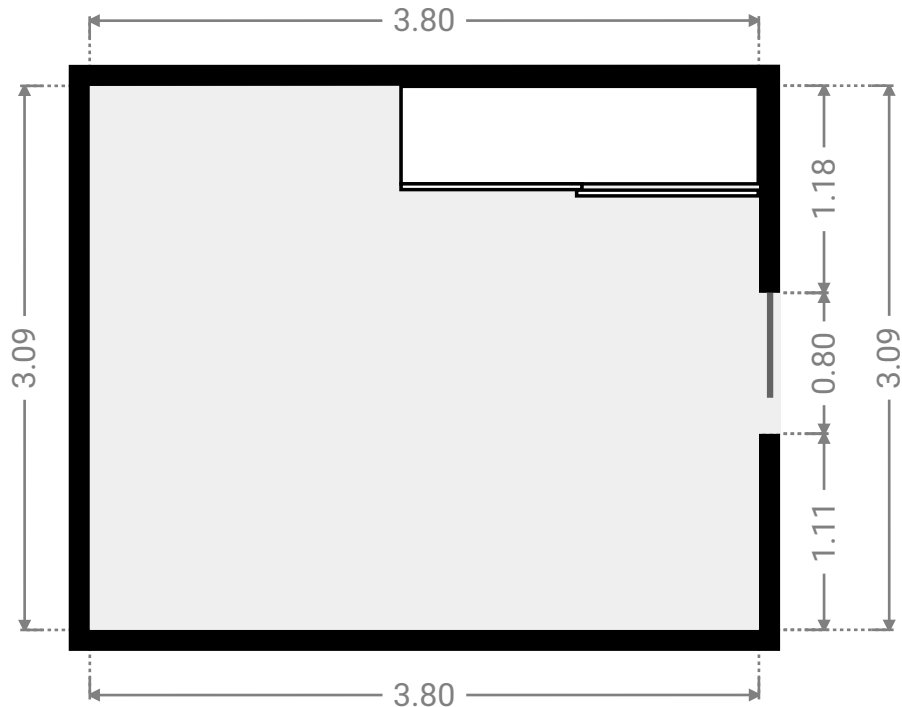
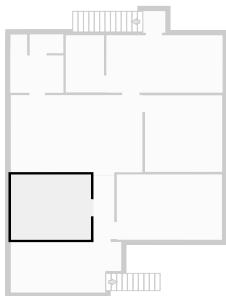

▼ **Bedroom**
1st Floor

WIDTH: 3.67 m • LENGTH: 3.64 m
AREA: 13.36 m² • PERIMETER: 14.62 m

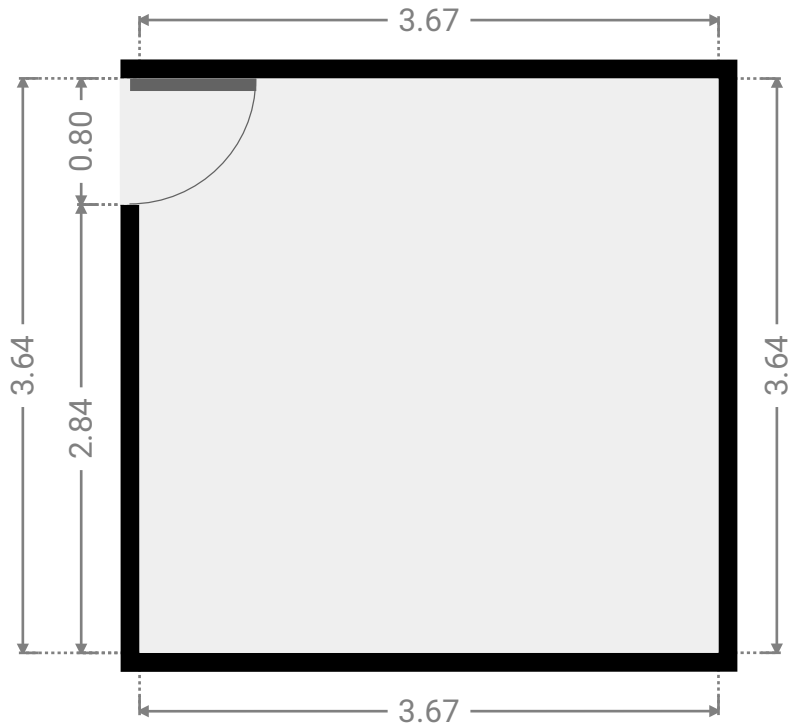
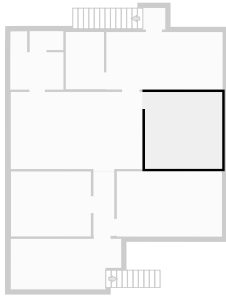

▼ **Hall**
1st Floor

WIDTH: 0.99 m • LENGTH: 3.04 m
AREA: 3.01 m² • PERIMETER: 8.06 m

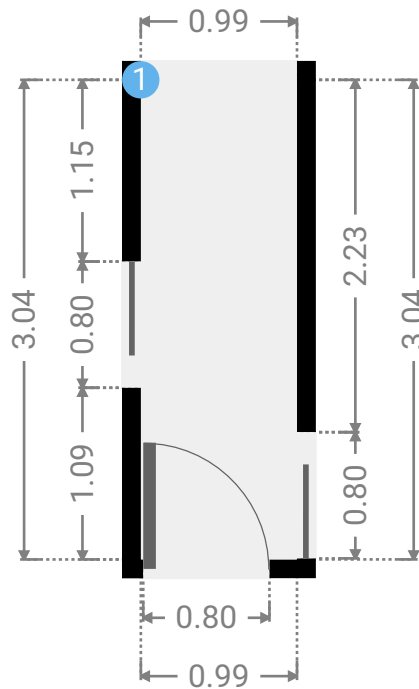
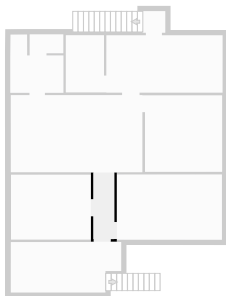

▼ Hall/1st Floor

1 OPENING

Height
0.00 m



▼ **Hall**
1st Floor

WIDTH: 1.08 m • LENGTH: 1.03 m
AREA: 1.11 m² • PERIMETER: 4.21 m

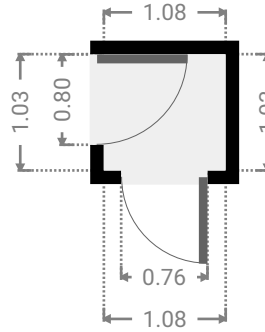
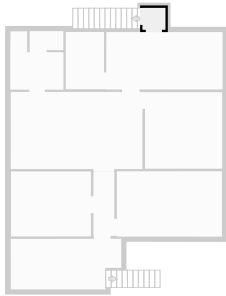

▼ **Kitchen**
1st Floor

WIDTH: 6.26 m • LENGTH: 3.67 m
AREA: 22.98 m² • PERIMETER: 19.86 m

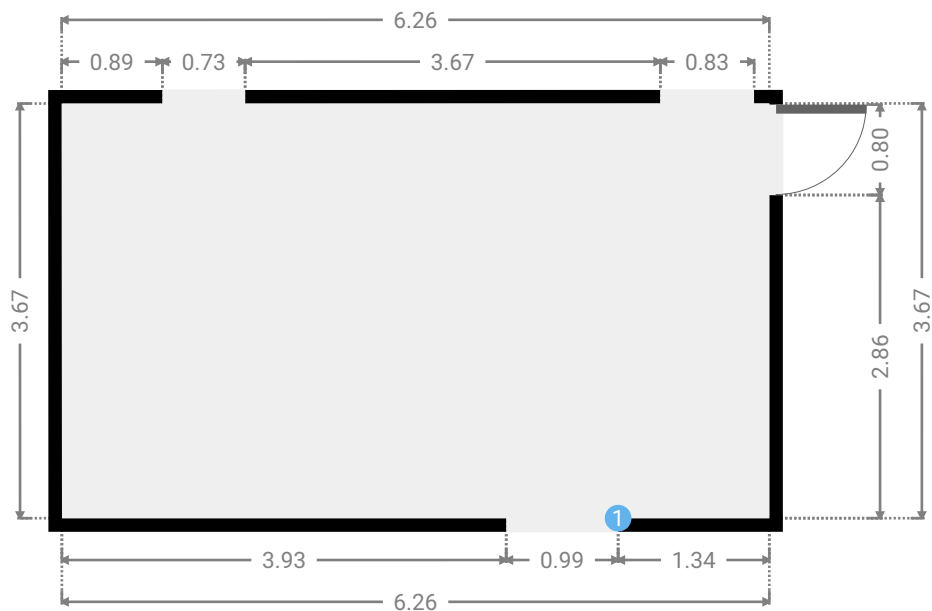
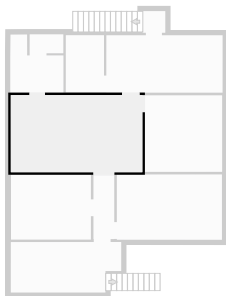

▼ **Kitchen**
1st Floor

WIDTH: 5.53 m • LENGTH: 2.73 m
AREA: 15.09 m² • PERIMETER: 16.52 m

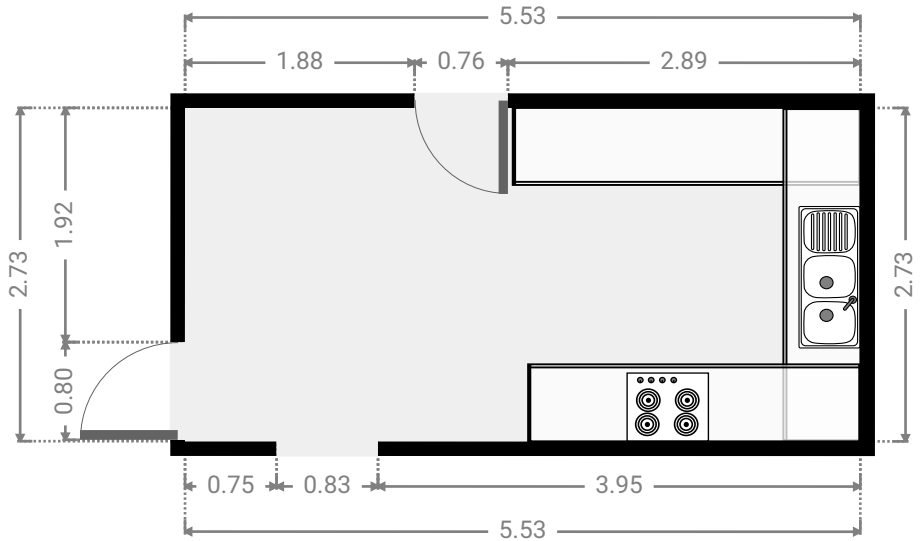
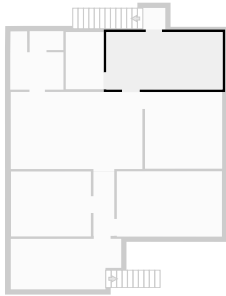

▼ **Other**
1st Floor

WIDTH: 5.25 m • LENGTH: 2.40 m
AREA: 11.85 m² • PERIMETER: 15.31 m

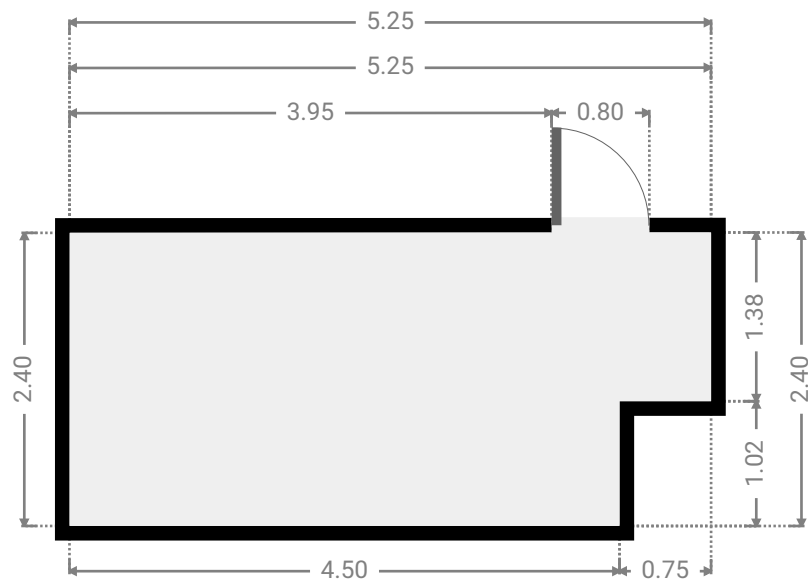
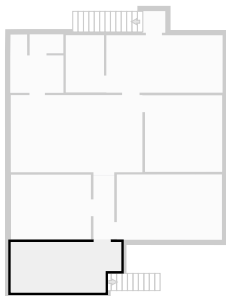

▼ **Primary Bedroom**
1st Floor

WIDTH: 5.00 m • LENGTH: 3.11 m
AREA: 15.54 m² • PERIMETER: 16.21 m

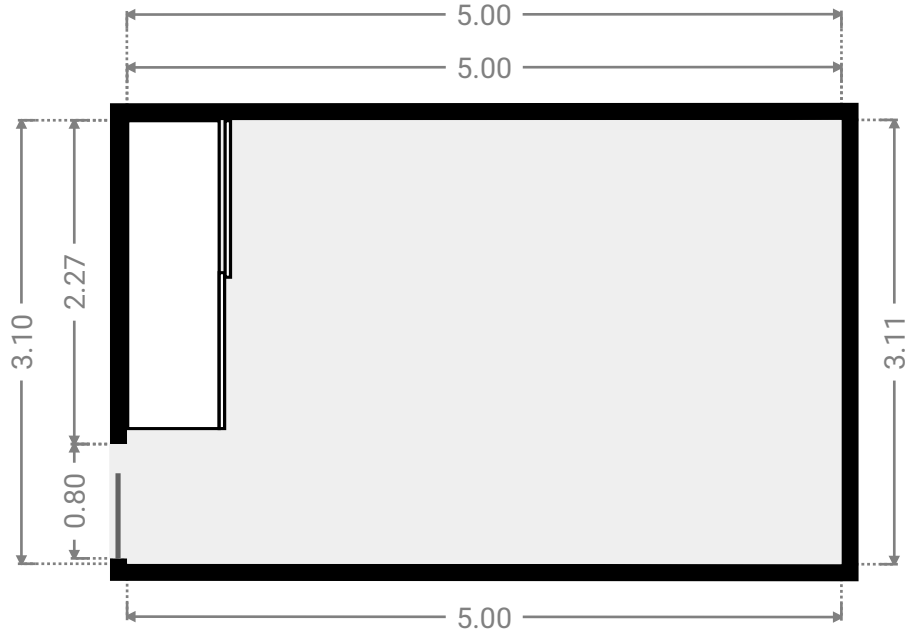
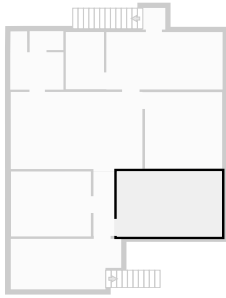

▼ **Study**
1st Floor

WIDTH: 2.53 m • LENGTH: 1.78 m
AREA: 4.50 m² • PERIMETER: 8.62 m

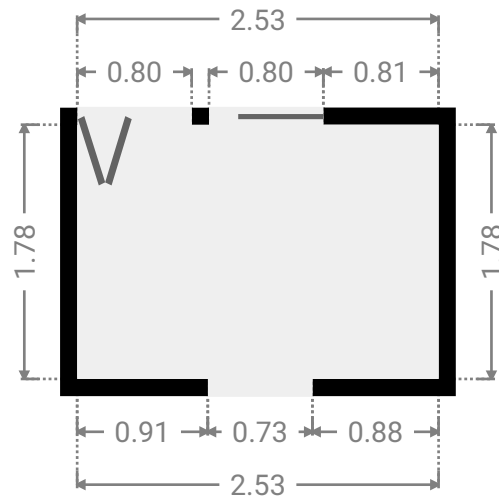
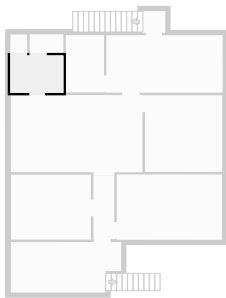

▼ **Closet**
1st Floor

WIDTH: 0.80 m • LENGTH: 0.88 m
AREA: 0.70 m² • PERIMETER: 3.35 m

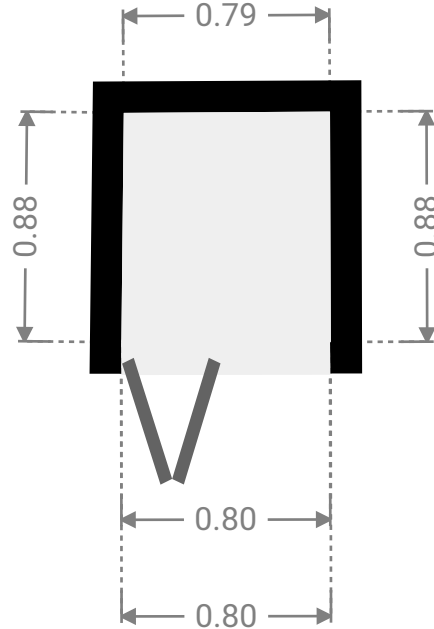
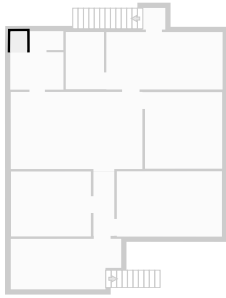

▼ **Toilet**
1st Floor

WIDTH: 1.60 m • LENGTH: 0.90 m
AREA: 1.44 m² • PERIMETER: 5.00 m

