

108 Larcombe Street

Ground Floor



THIS FLOORPLAN IS PROVIDED WITHOUT WARRANTY OF ANY KIND. SENSOPIA DISCLAIMS ANY WARRANTY INCLUDING, WITHOUT LIMITATION, SATISFACTORY QUALITY OR ACCURACY OF DIMENSIONS.



108 Larcombe Street

Laundry Room

Width: 1.97 m
Length: 2.98 m
Area: 5.87 m²
Perimeter: 9.90 m

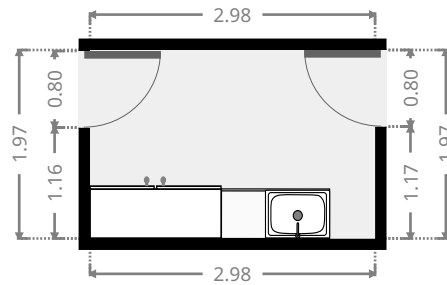
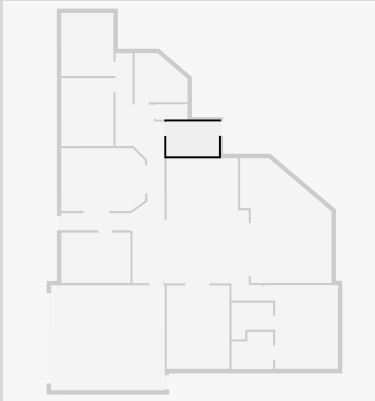

Outdoor Area

Width: 5.21 m
Length: 7.12 m
Area: 29.02 m²
Perimeter: 22.73 m

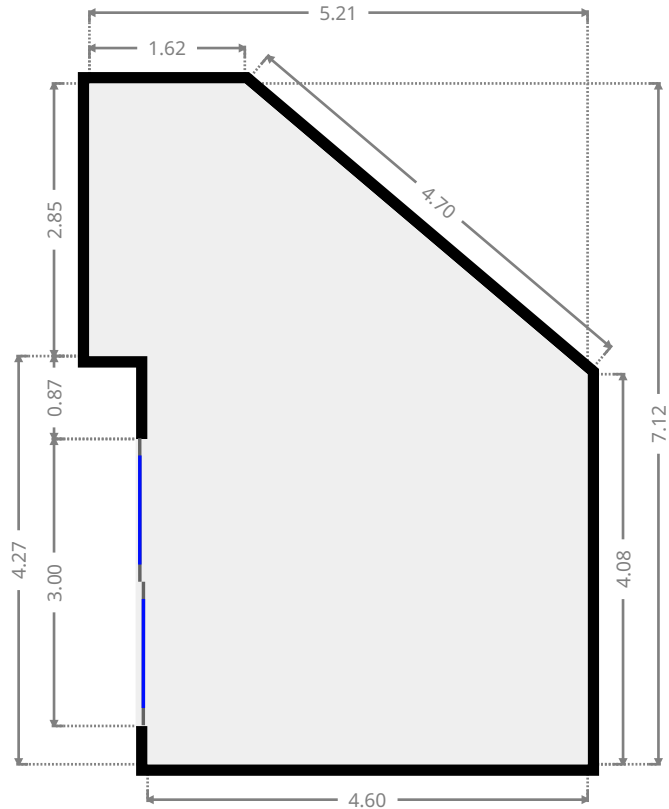
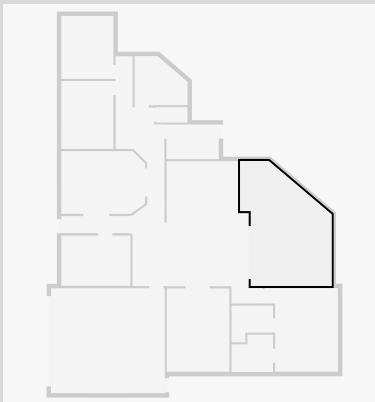

THIS FLOORPLAN IS PROVIDED WITHOUT WARRANTY OF ANY KIND. SENSOPIA DISCLAIMS ANY WARRANTY INCLUDING, WITHOUT LIMITATION, SATISFACTORY QUALITY OR ACCURACY OF DIMENSIONS.

108 Larcombe Street

Garage

Width: 5.99 m
Length: 6.49 m
Area: 38.75 m²
Perimeter: 24.92 m

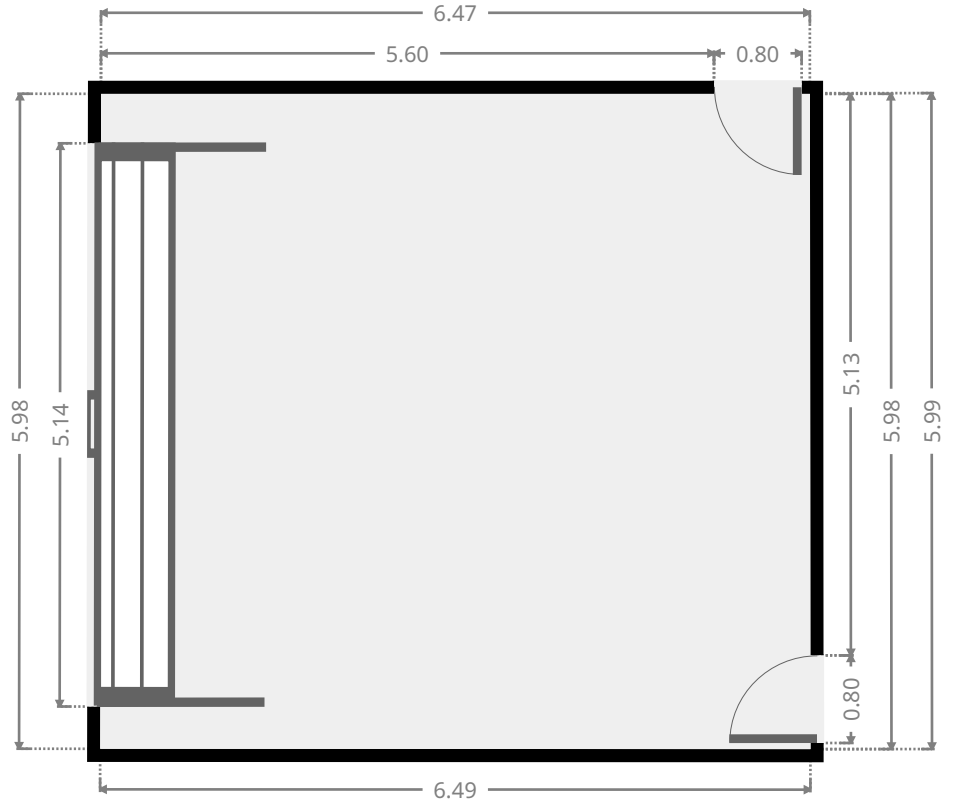
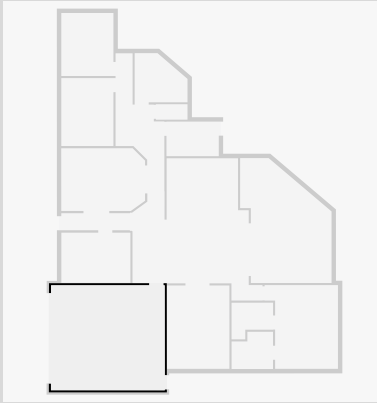

Bedroom

Width: 2.97 m
Length: 3.59 m
Area: 10.66 m²
Perimeter: 13.12 m

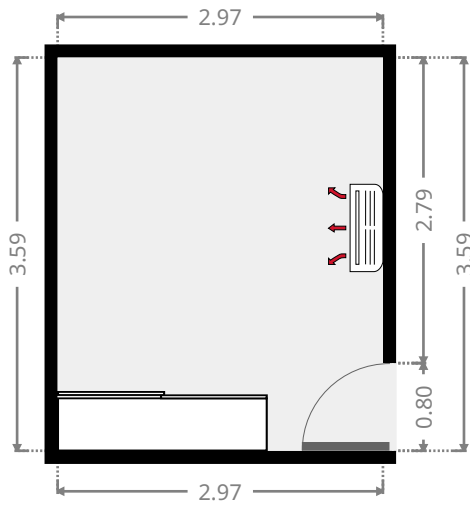
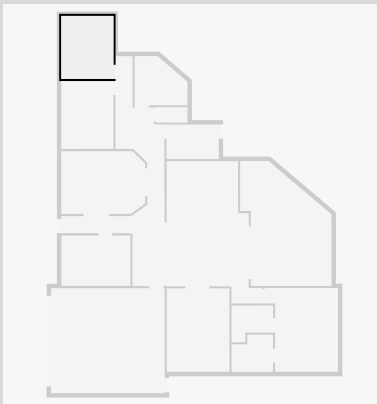

108 Larcombe Street

Bedroom

Width: 2.97 m
Length: 3.87 m
Area: 11.49 m²
Perimeter: 13.68 m

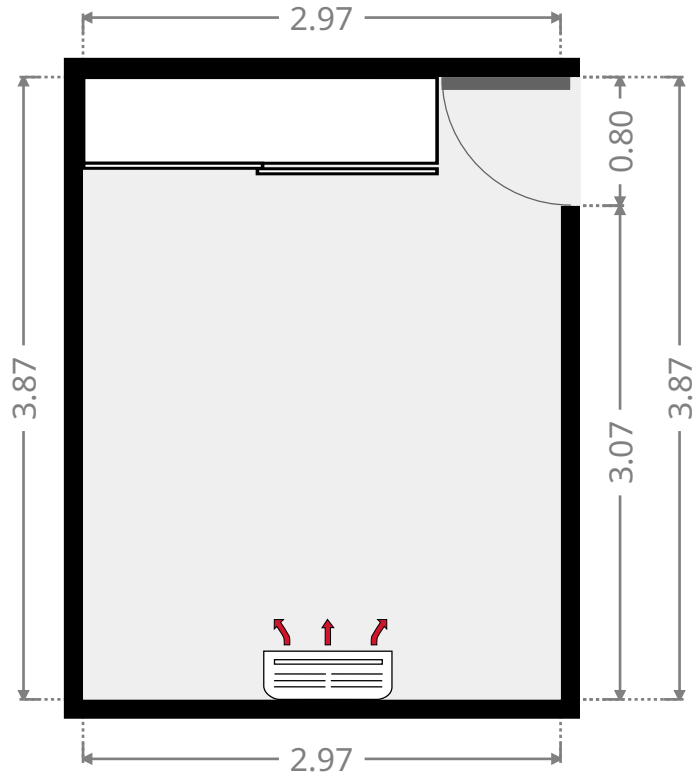
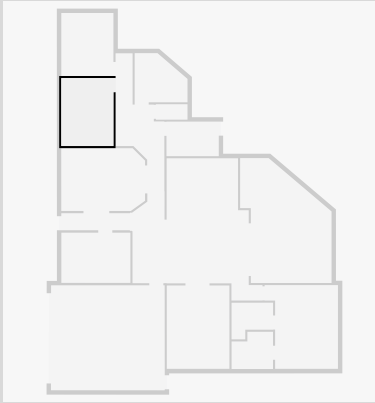

Bathroom

Width: 2.80 m
Length: 3.01 m
Area: 7.18 m²
Perimeter: 10.70 m

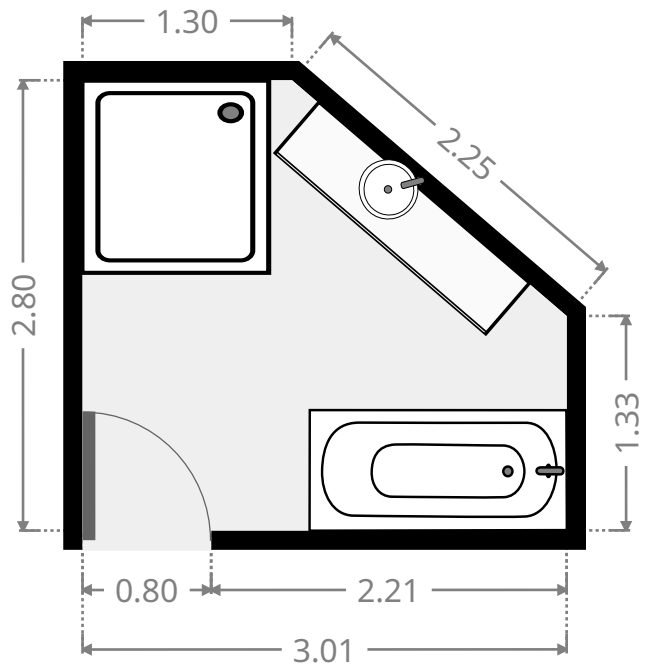
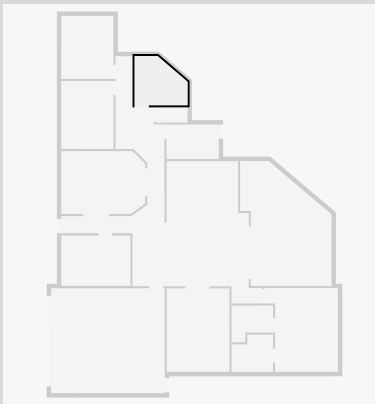

108 Larcombe Street

Toilet / Half Bath

Width: 0.88 m
Length: 1.80 m
Area: 1.58 m²
Perimeter: 5.36 m

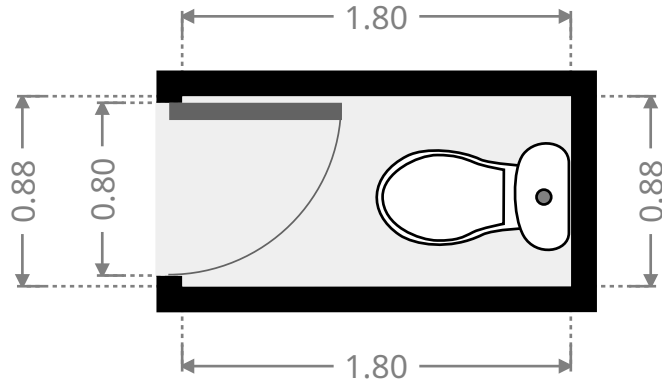
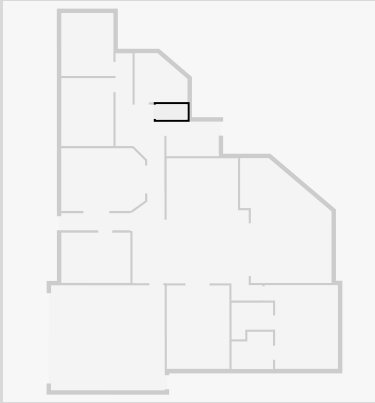

Closet

Width: 2.09 m
Length: 2.37 m
Area: 4.07 m²
Perimeter: 8.91 m

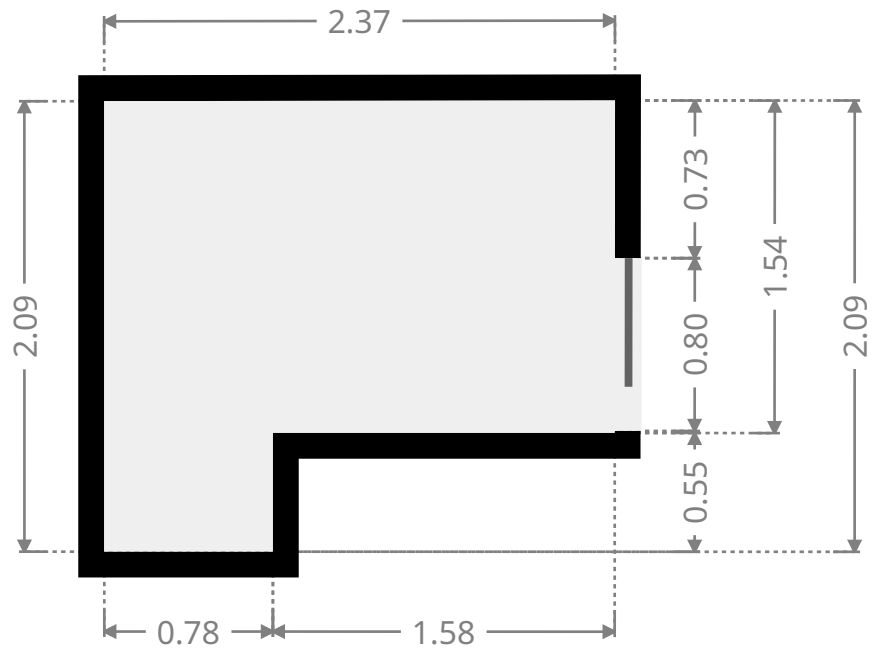
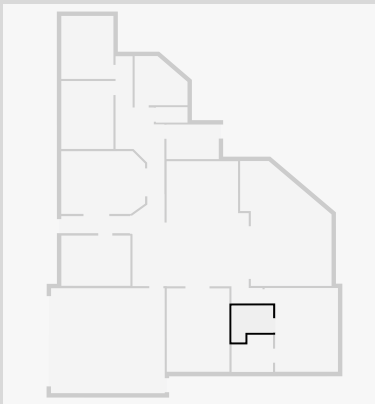

108 Larcombe Street

Bathroom

Width: 2.12 m
 Length: 2.36 m
 Area: 4.51 m²
 Perimeter: 8.96 m

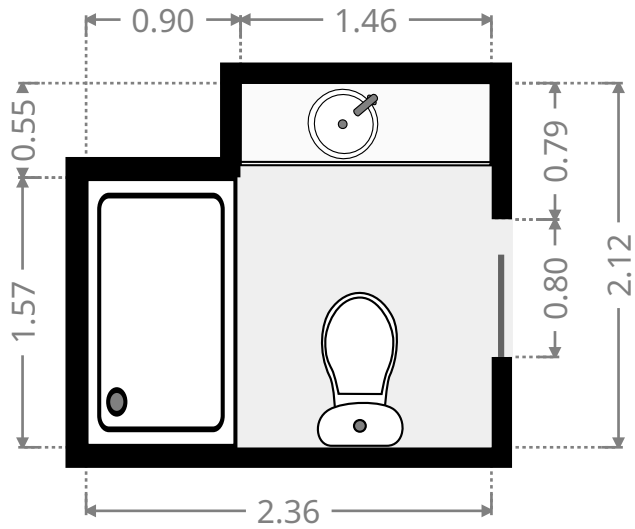
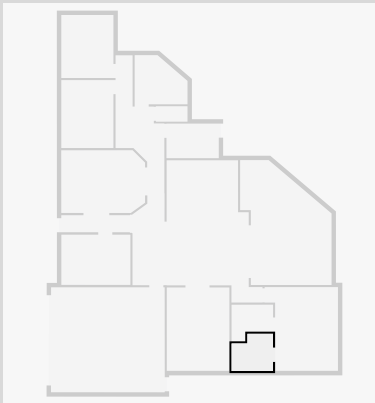

Hall

Width: 0.97 m
 Length: 3.91 m
 Area: 3.80 m²
 Perimeter: 9.77 m

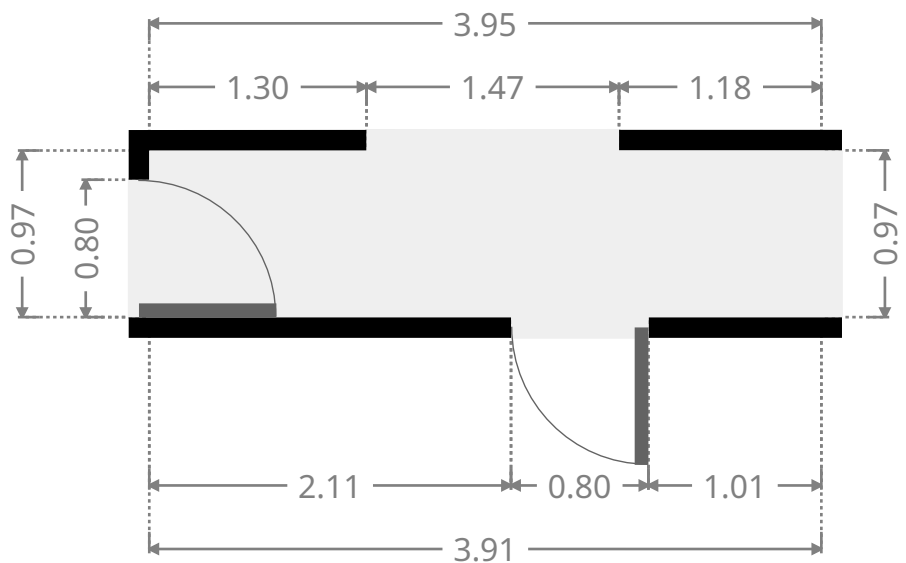
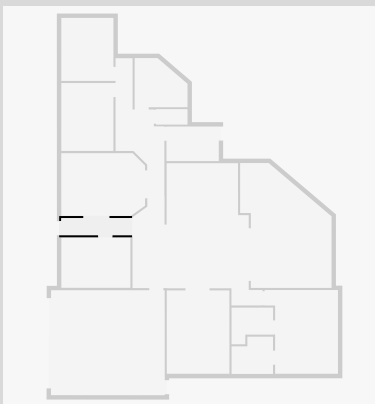

THIS FLOORPLAN IS PROVIDED WITHOUT WARRANTY OF ANY KIND. SENSOPIA DISCLAIMS ANY WARRANTY INCLUDING, WITHOUT LIMITATION, SATISFACTORY QUALITY OR ACCURACY OF DIMENSIONS.

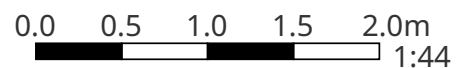

108 Larcombe Street

Hall

Width: 2.78 m
 Length: 7.86 m
 Area: 11.66 m²
 Perimeter: 20.83 m

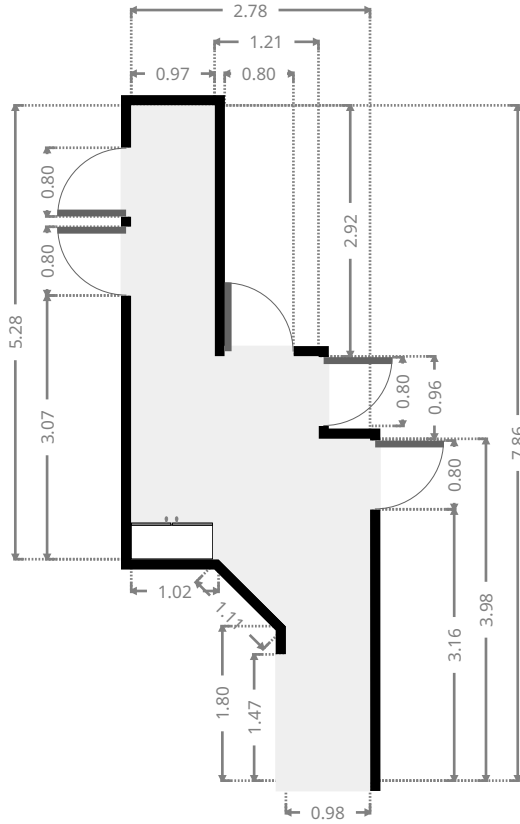
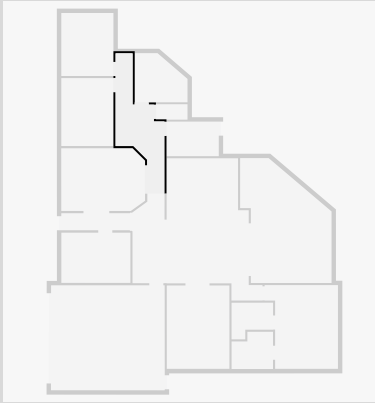

Bedroom

Width: 2.86 m
 Length: 3.93 m
 Area: 11.25 m²
 Perimeter: 13.59 m

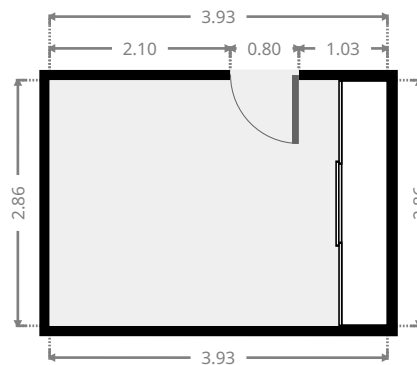
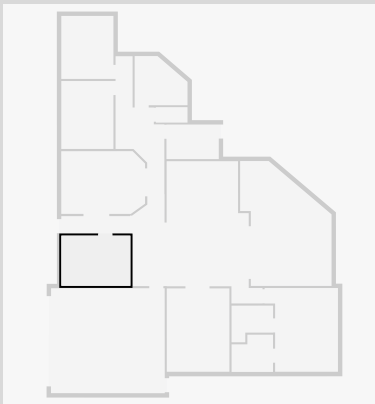

108 Larcombe Street

Master Bedroom

Width: 4.18 m
 Length: 4.77 m
 Area: 17.60 m²
 Perimeter: 17.90 m

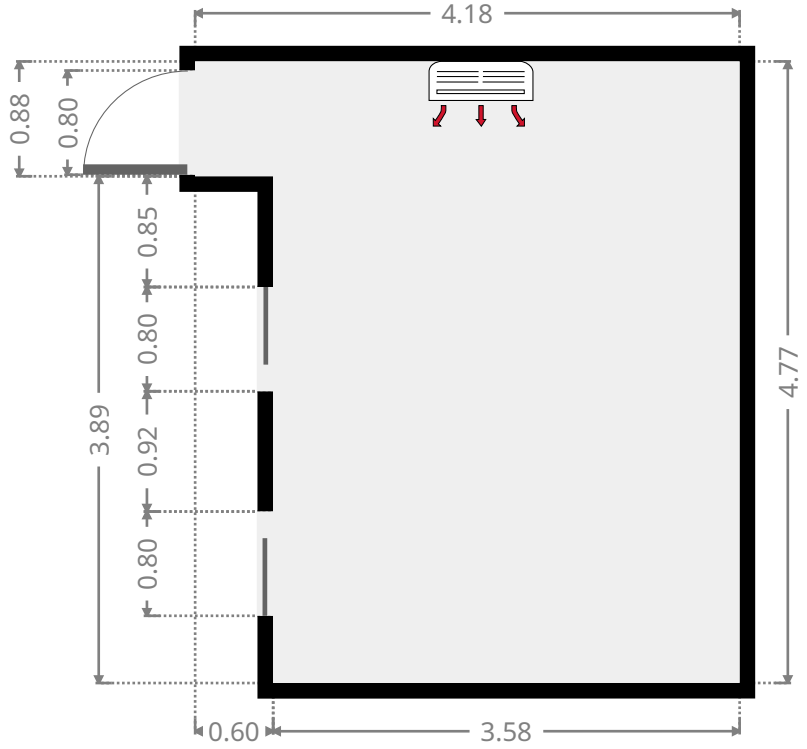
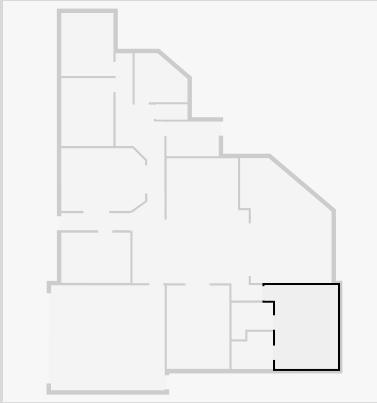

Living Room

Width: 3.57 m
 Length: 4.75 m
 Area: 16.96 m²
 Perimeter: 16.64 m

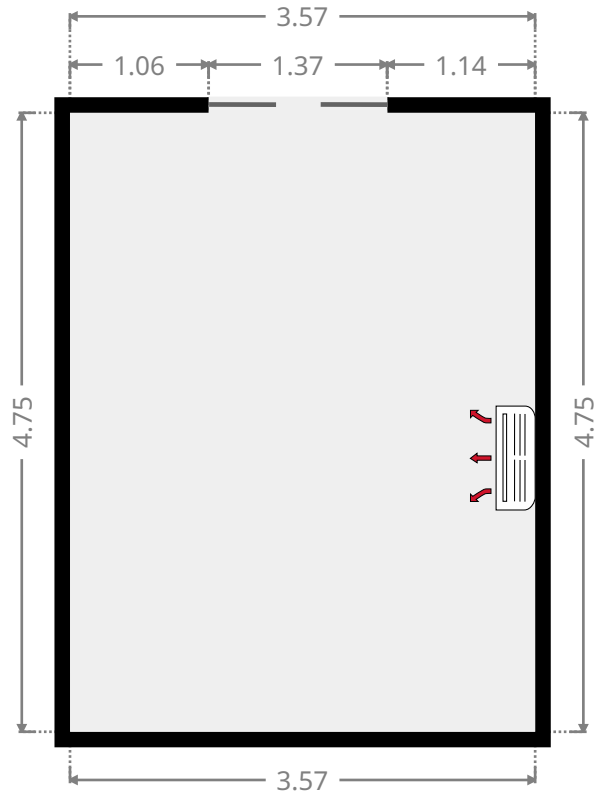
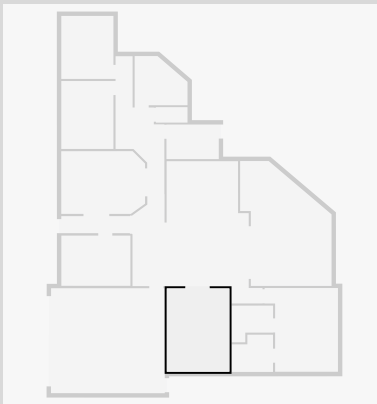

THIS FLOORPLAN IS PROVIDED WITHOUT WARRANTY OF ANY KIND. SENSOPIA DISCLAIMS ANY WARRANTY INCLUDING, WITHOUT LIMITATION, SATISFACTORY QUALITY OR ACCURACY OF DIMENSIONS.

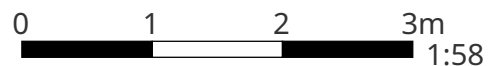

108 Larcombe Street

Kitchen

Width: 5.46 m
 Length: 8.11 m
 Area: 33.19 m²
 Perimeter: 27.14 m

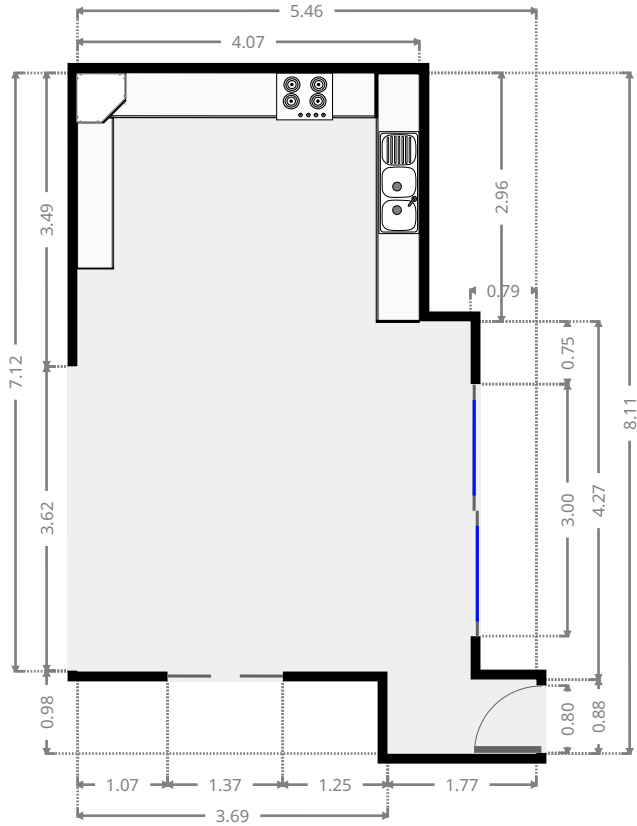
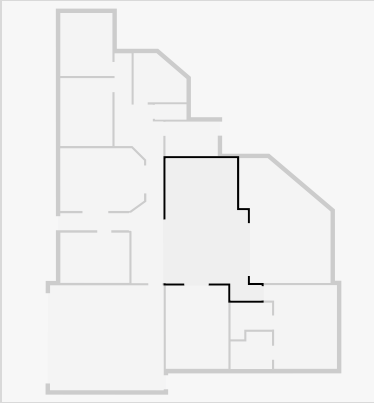

Dining Room

Width: 1.86 m
 Length: 5.12 m
 Area: 8.71 m²
 Perimeter: 13.49 m

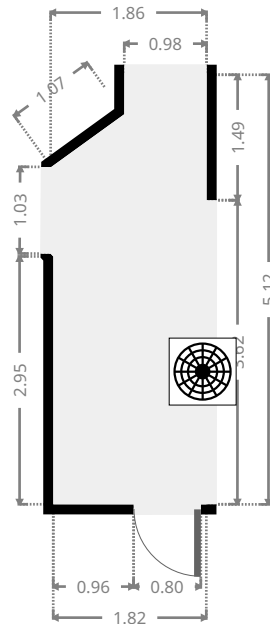
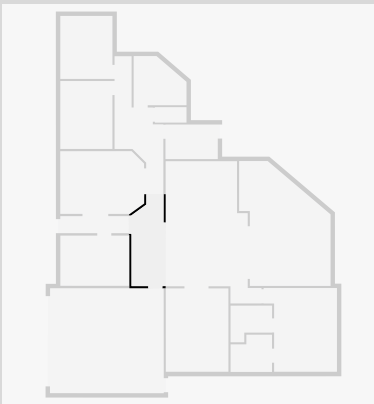

108 Larcombe Street

Living Room

Width: 3.57 m
Length: 4.78 m
Area: 16.57 m²
Perimeter: 15.89 m

