

105 Rose street

SUBMITTED BY

Ray White Rockhampton Casey
stockers@cqoz.com

CREATED ON

2022-03-16

Floors

1

▼ Ground Floor



FLOORS: 1

▼ **Hall**
Ground Floor

WIDTH: 1.83 m • LENGTH: 1.66 m
AREA: 3.04 m² • PERIMETER: 6.98 m

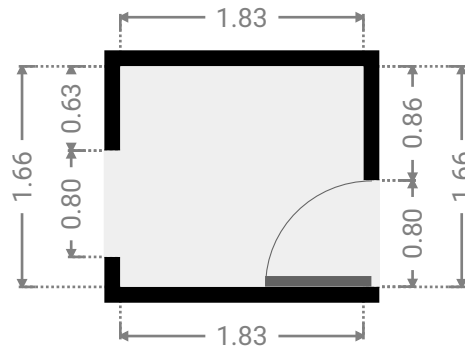
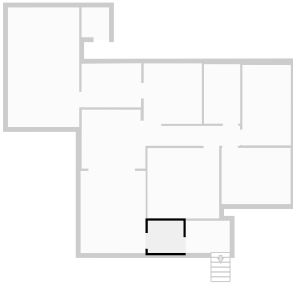

▼ **Living Room**
Ground Floor

WIDTH: 3.36 m • LENGTH: 4.24 m
AREA: 14.25 m² • PERIMETER: 15.20 m

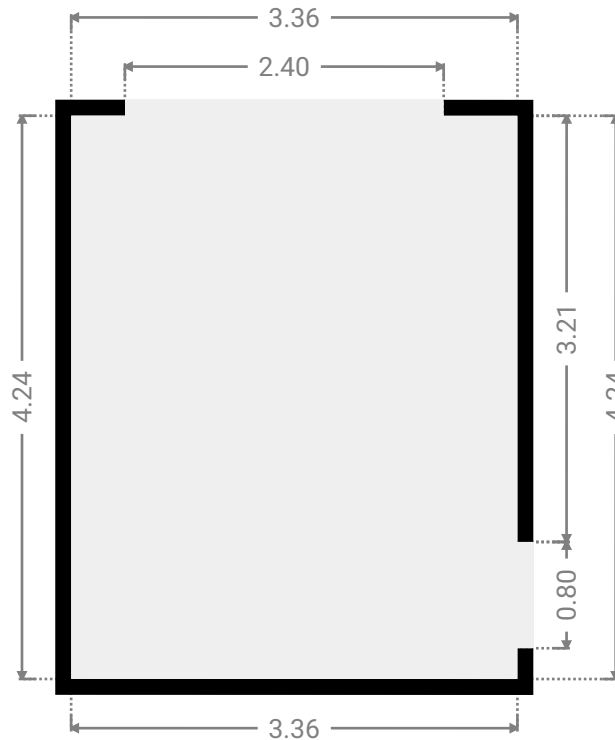
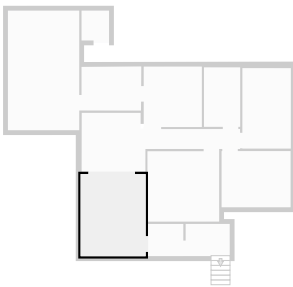

▼ **Dining Room**
Ground Floor

WIDTH: 3.29 m • LENGTH: 3.04 m
AREA: 9.77 m² • PERIMETER: 12.66 m

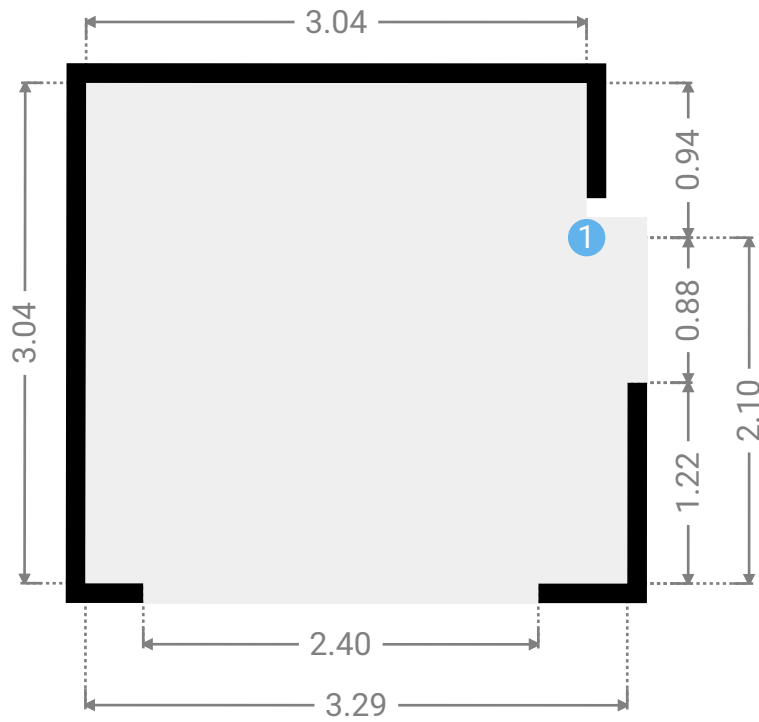
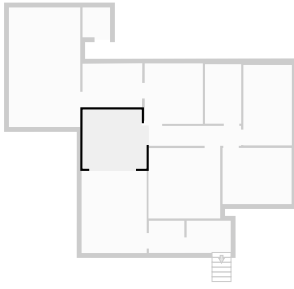

▼ **Dining Room/**Ground Floor

1 OPENING

Height
0.00 m



▼ Hall
Ground Floor

WIDTH: 4.88 m • LENGTH: 1.03 m
AREA: 5.01 m² • PERIMETER: 11.81 m

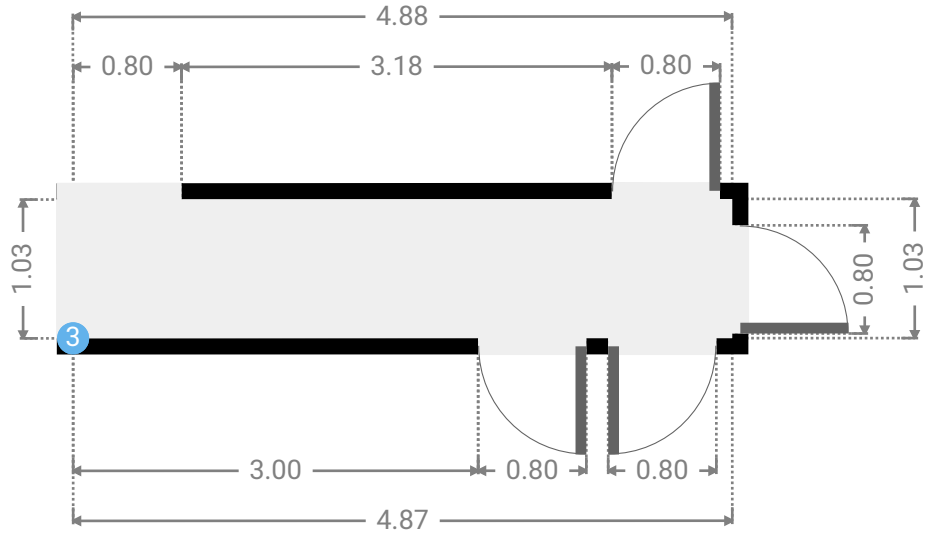
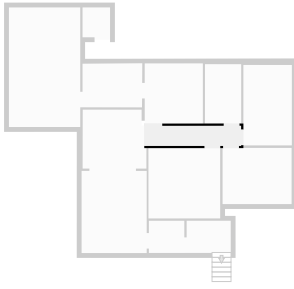

▼ Hall/Ground Floor

2 OPENING

Height
0.00 m



3 OPENING

Height
0.00 m



▼ **Bedroom**
Ground Floor

WIDTH: 3.70 m • LENGTH: 3.63 m
AREA: 13.43 m² • PERIMETER: 14.66 m

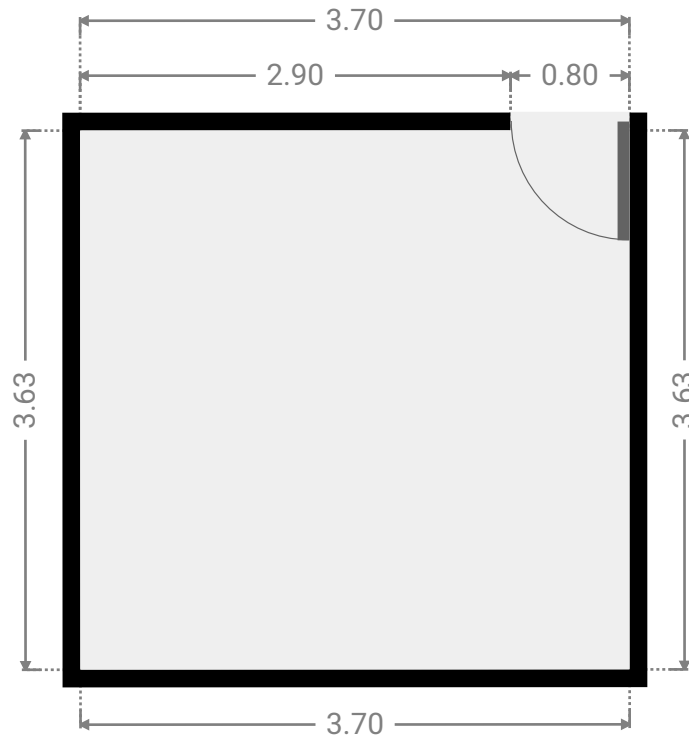
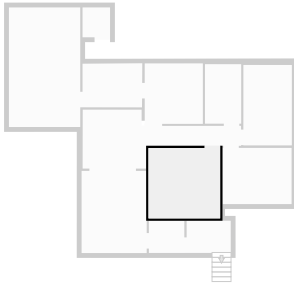

▼ **Bedroom**
Ground Floor

WIDTH: 3.56 m • LENGTH: 2.90 m
AREA: 10.32 m² • PERIMETER: 12.92 m

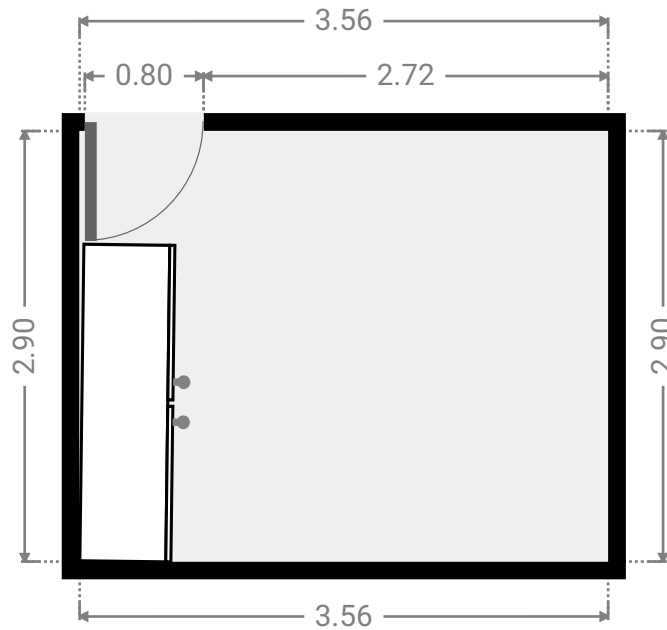
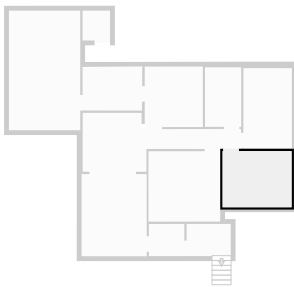

▼ **Bedroom**
Ground Floor

WIDTH: 2.50 m • LENGTH: 4.15 m
AREA: 10.38 m² • PERIMETER: 13.30 m

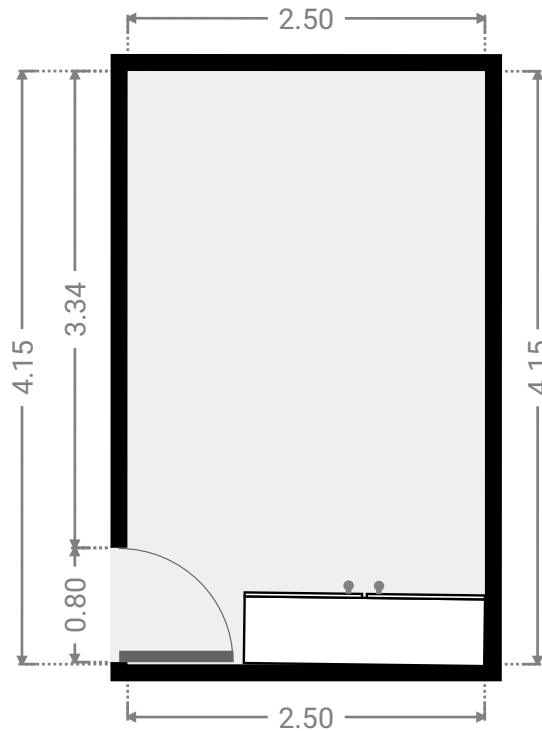
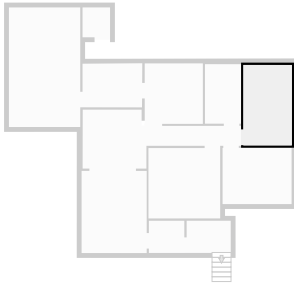

▼ **Bathroom**
Ground Floor

WIDTH: 1.87 m • LENGTH: 3.07 m
AREA: 5.74 m² • PERIMETER: 9.88 m

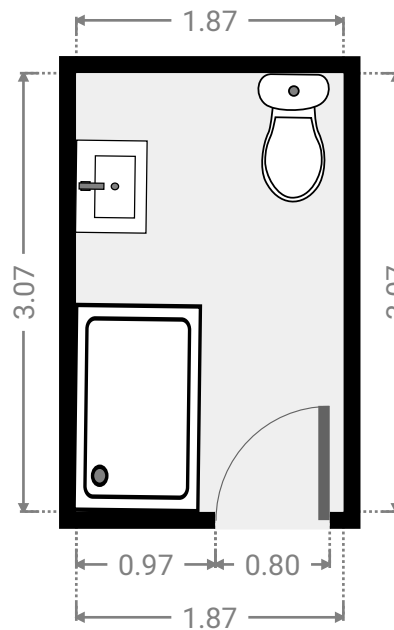
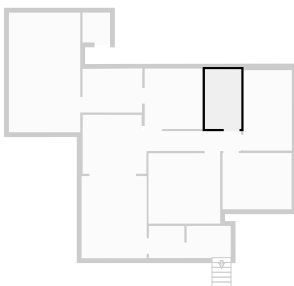

▼ Kitchen
Ground Floor

WIDTH: 3.00 m • LENGTH: 3.12 m
AREA: 9.36 m² • PERIMETER: 12.24 m

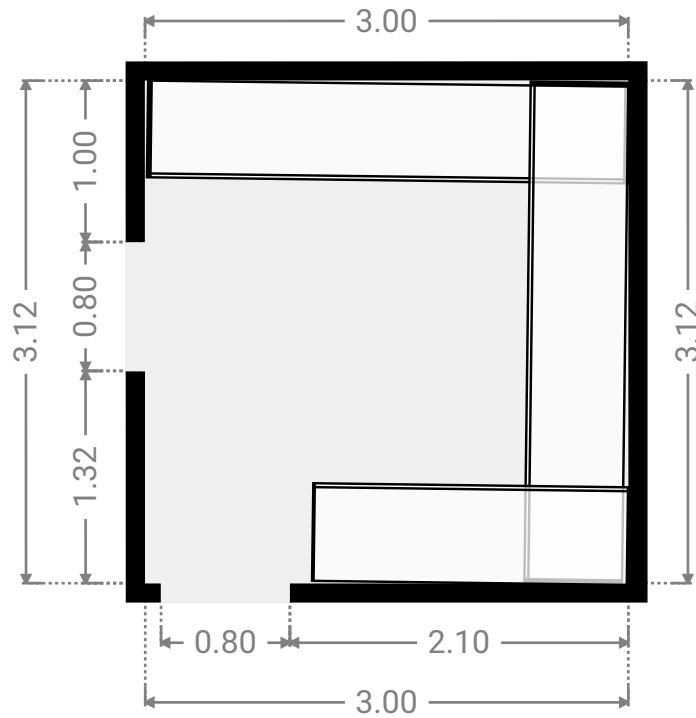
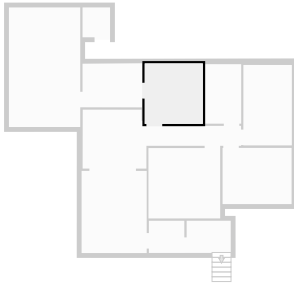

▼ Laundry Room
Ground Floor

WIDTH: 3.10 m • LENGTH: 2.28 m
AREA: 6.96 m² • PERIMETER: 10.68 m

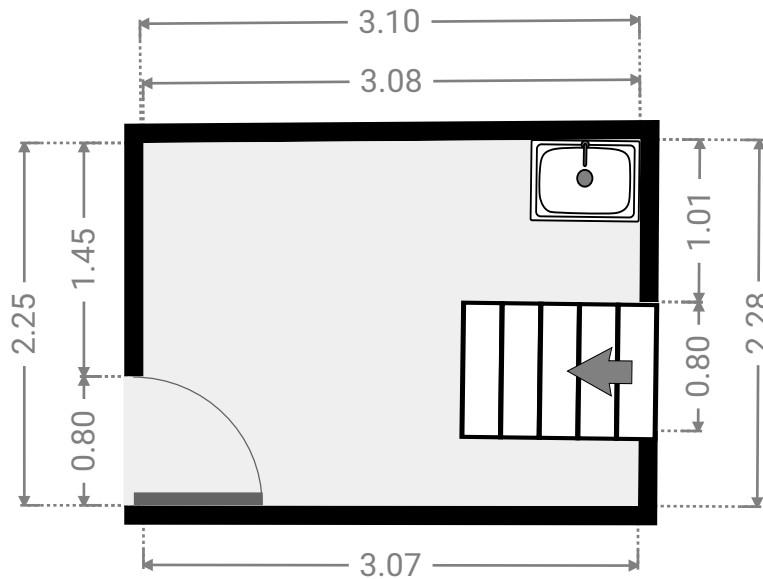
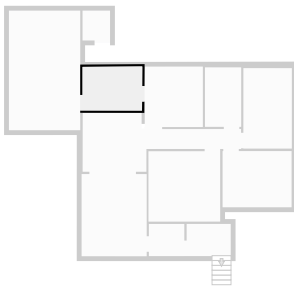

▼ **Garage**
Ground Floor

WIDTH: 3.68 m • LENGTH: 6.17 m
AREA: 22.71 m² • PERIMETER: 19.70 m

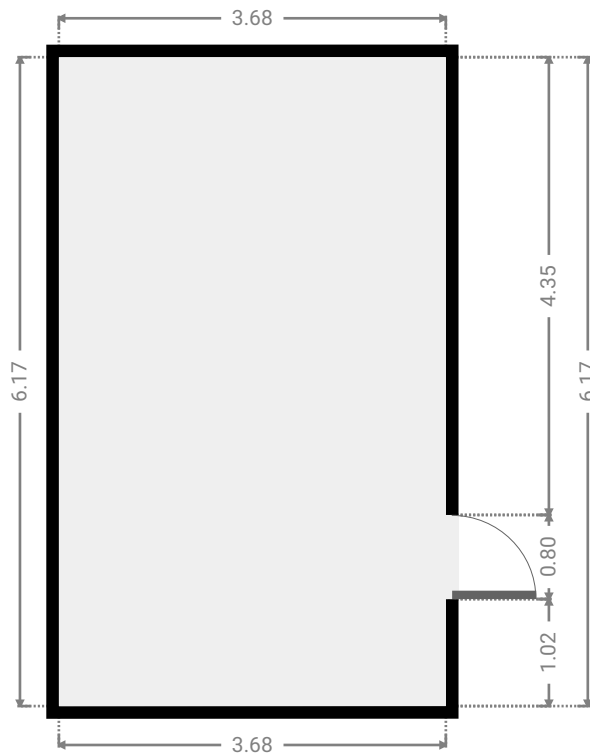
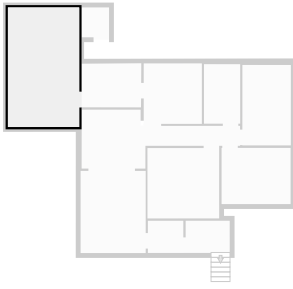

▼ **Toilet**
Ground Floor

WIDTH: 1.42 m • LENGTH: 1.54 m
AREA: 2.19 m² • PERIMETER: 5.92 m

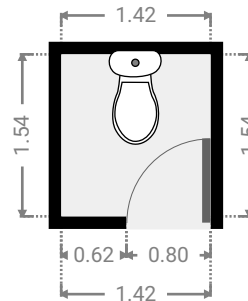
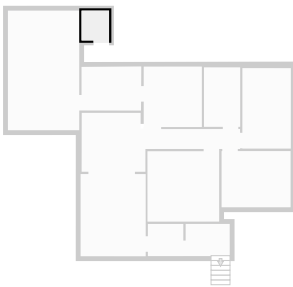

▼ Other
Ground Floor

WIDTH: 2.27 m • LENGTH: 1.66 m
AREA: 3.77 m² • PERIMETER: 7.87 m

