

# 105 Boland Street

Created on  
2021-02-16

Floors  
2

▼ Ground Floor

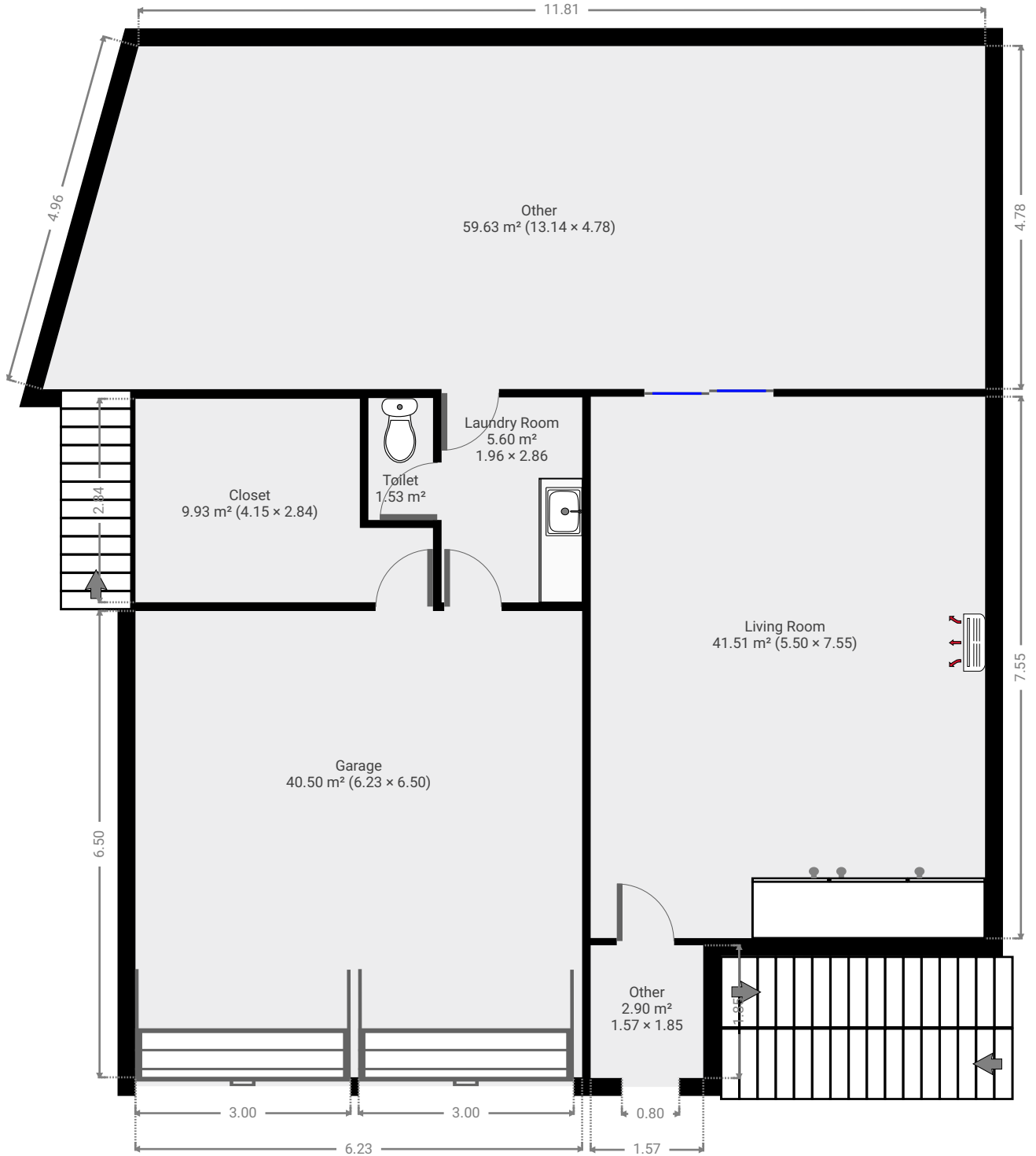

▼ **Garage**  
Ground Floor

WIDTH: 6.23 m • LENGTH: 6.50 m  
AREA: 40.50 m<sup>2</sup> • PERIMETER: 25.46 m

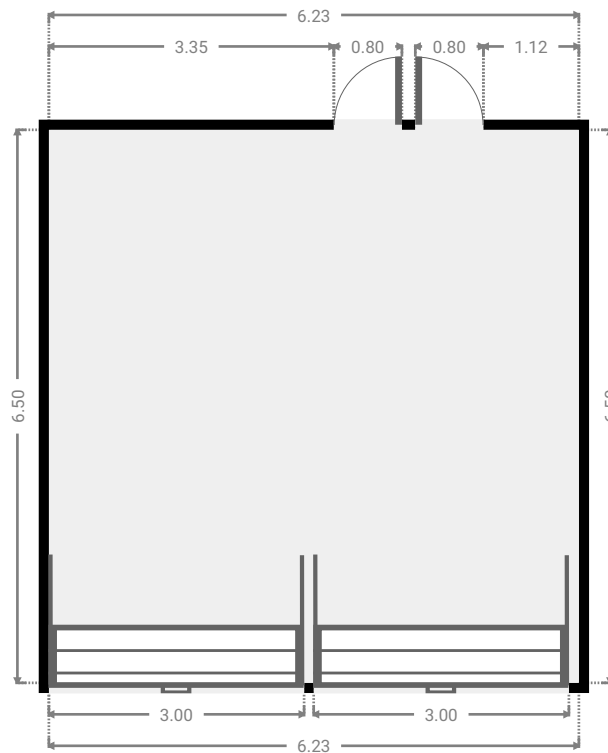
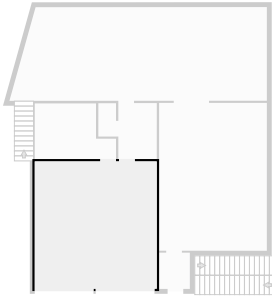

▼ **Closet**  
Ground Floor

WIDTH: 4.15 m • LENGTH: 2.84 m  
AREA: 9.93 m<sup>2</sup> • PERIMETER: 13.97 m

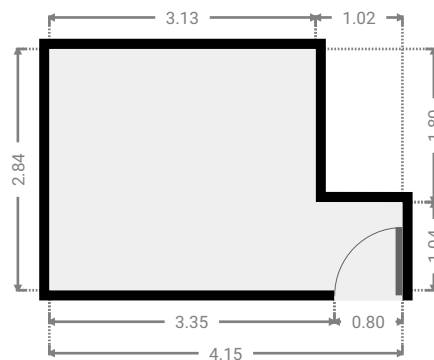
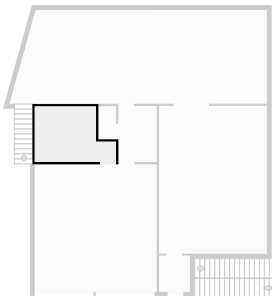

▼ Living Room  
Ground Floor

WIDTH: 5.50 m • LENGTH: 7.55 m  
AREA: 41.51 m<sup>2</sup> • PERIMETER: 26.10 m

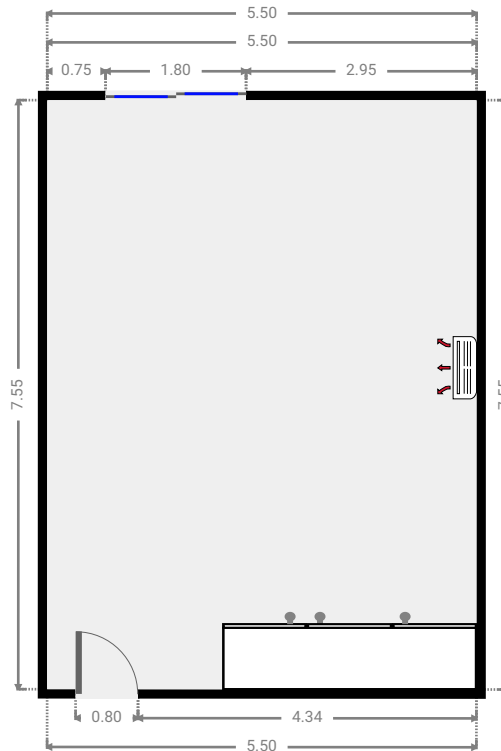
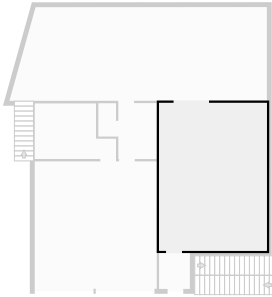

▼ Other  
Ground Floor

WIDTH: 1.57 m • LENGTH: 1.85 m  
AREA: 2.90 m<sup>2</sup> • PERIMETER: 6.84 m

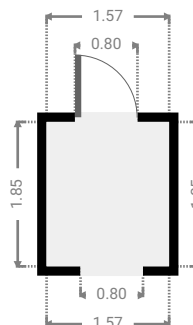
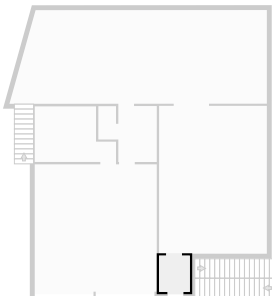

▼ **Laundry Room**  
Ground Floor

WIDTH: 1.96 m • LENGTH: 2.86 m  
AREA: 5.60 m<sup>2</sup> • PERIMETER: 9.64 m

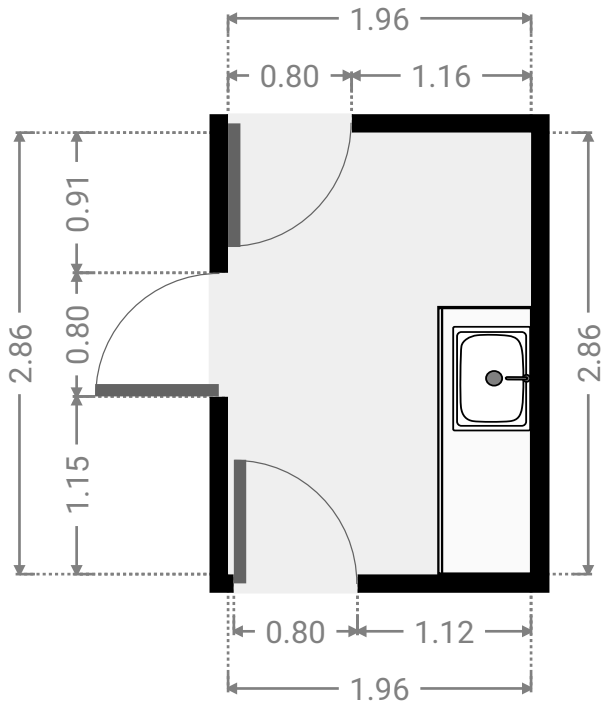
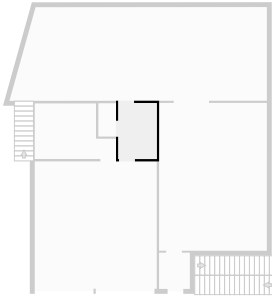

▼ **Toilet**  
Ground Floor

WIDTH: 0.90 m • LENGTH: 1.70 m  
AREA: 1.53 m<sup>2</sup> • PERIMETER: 5.20 m

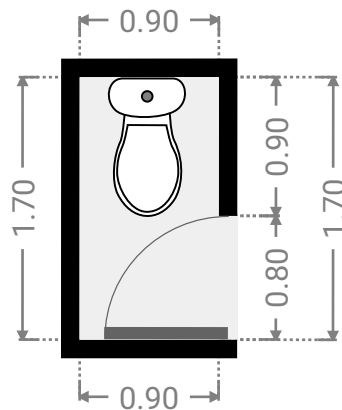
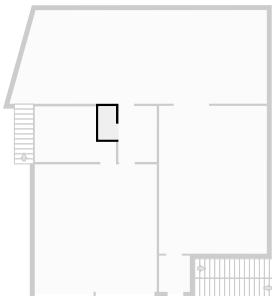

▼ Other  
Ground Floor

WIDTH: 13.14 m • LENGTH: 4.78 m  
AREA: 59.63 m<sup>2</sup> • PERIMETER: 34.69 m

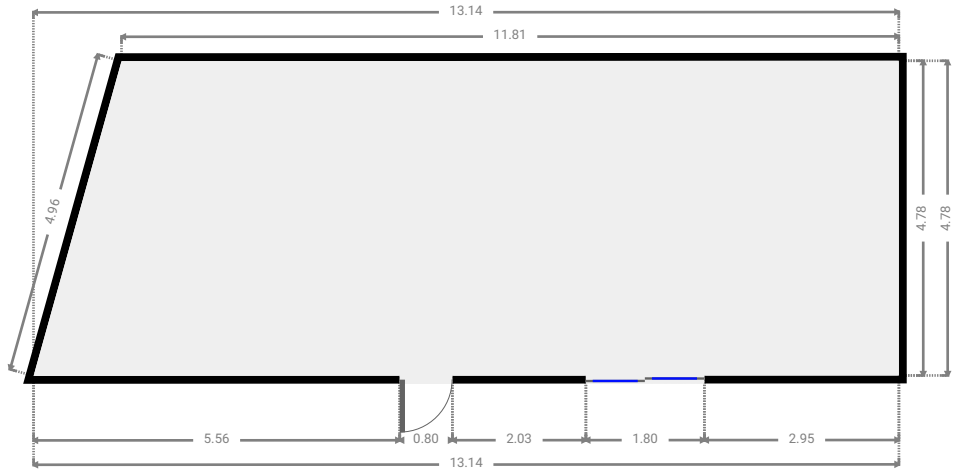
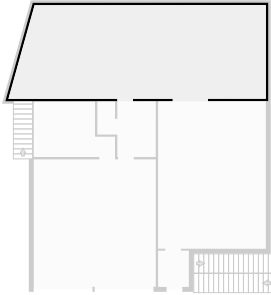

▼ 1st Floor

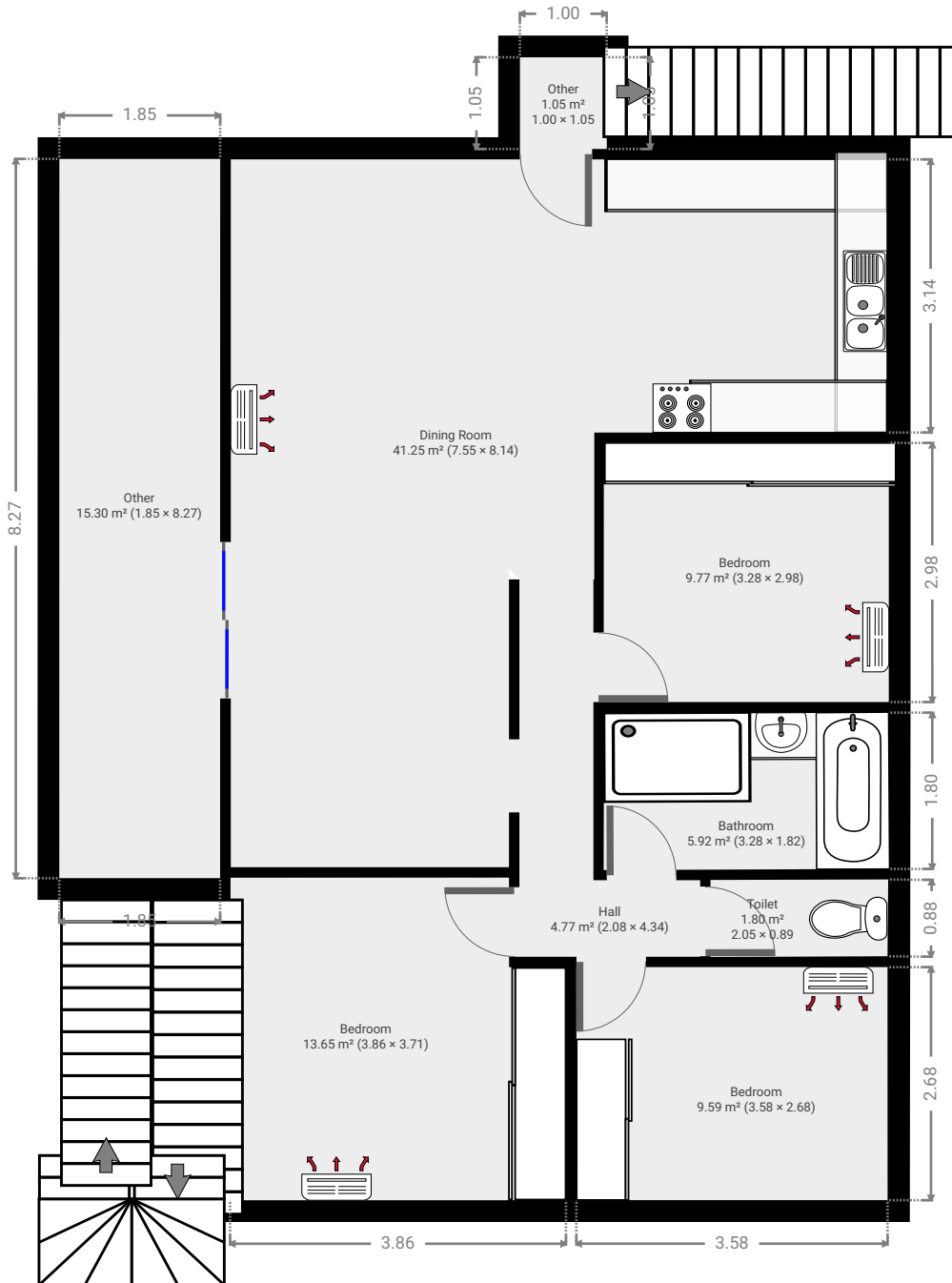

▼ Dining Room  
1st Floor

WIDTH: 8.14 m • LENGTH: 7.55 m  
AREA: 41.25 m<sup>2</sup> • PERIMETER: 31.38 m

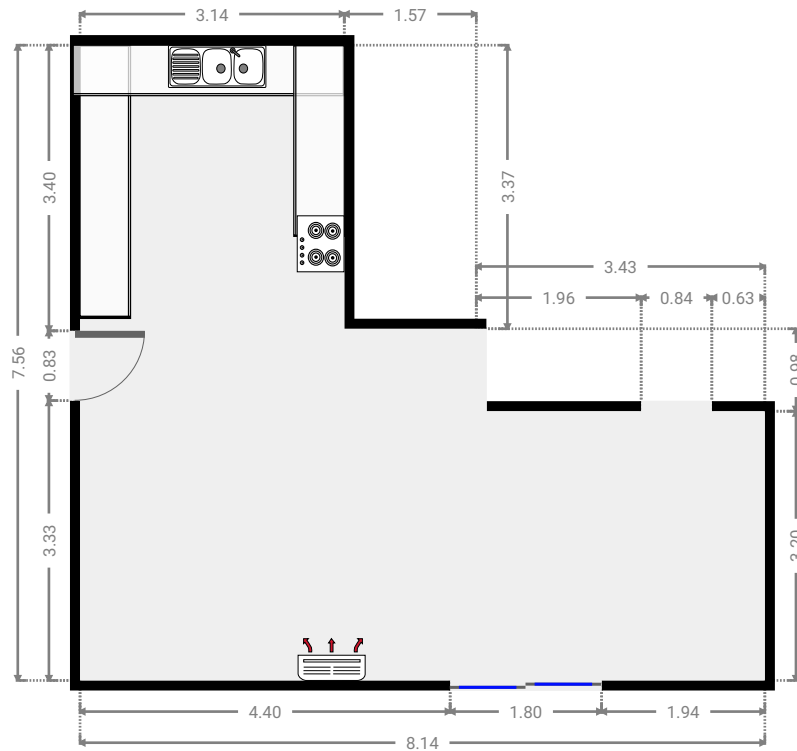

▼ Hall  
1st Floor

WIDTH: 4.34 m • LENGTH: 2.08 m  
AREA: 4.77 m<sup>2</sup> • PERIMETER: 12.84 m

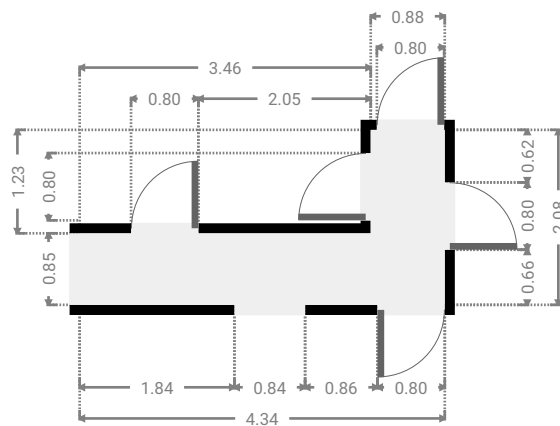
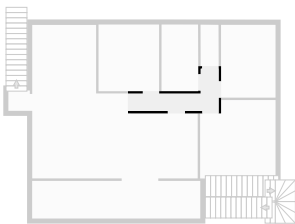



▼ **Bedroom**  
1st Floor

WIDTH: 2.98 m • LENGTH: 3.28 m  
AREA: 9.77 m<sup>2</sup> • PERIMETER: 12.52 m

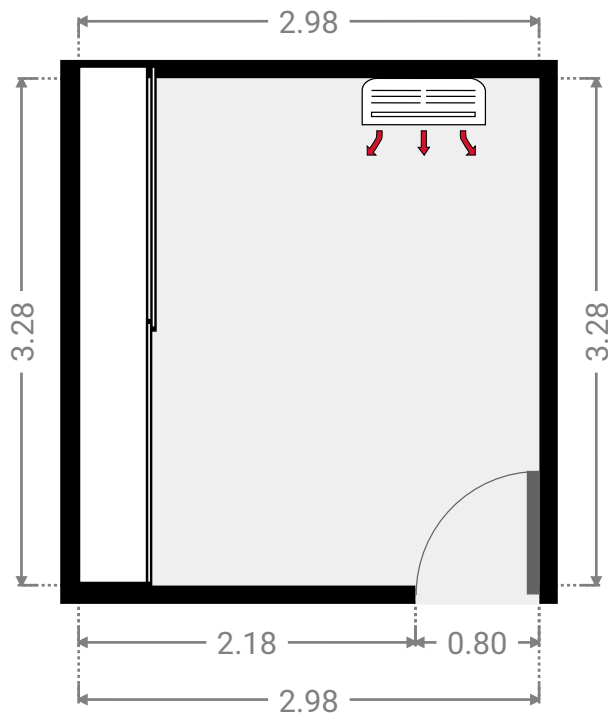
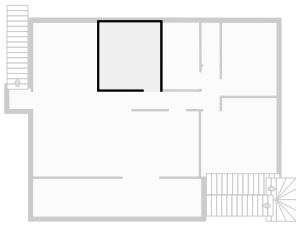

▼ **Bathroom**  
1st Floor

WIDTH: 1.82 m • LENGTH: 3.28 m  
AREA: 5.92 m<sup>2</sup> • PERIMETER: 10.17 m

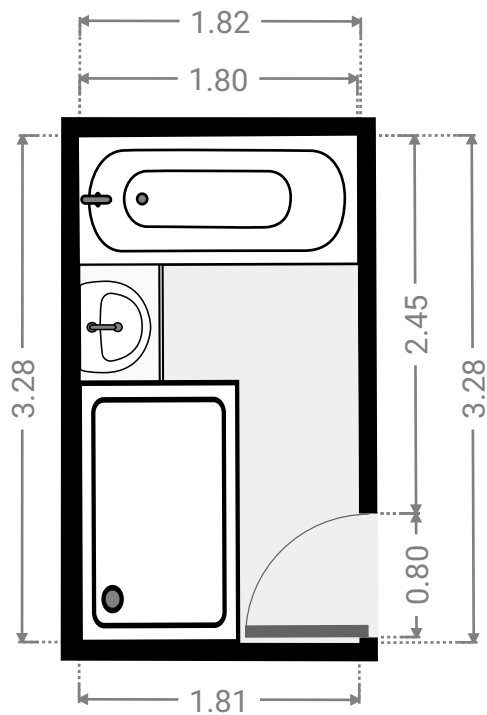
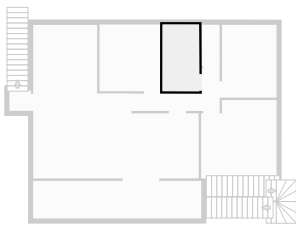

▼ Toilet  
1st Floor

WIDTH: 0.89 m • LENGTH: 2.05 m  
AREA: 1.80 m<sup>2</sup> • PERIMETER: 5.85 m

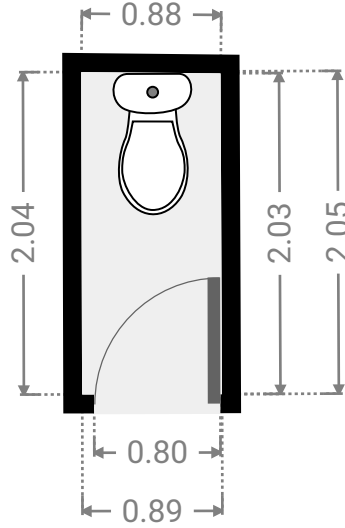

▼ Bedroom  
1st Floor

WIDTH: 2.68 m • LENGTH: 3.58 m  
AREA: 9.59 m<sup>2</sup> • PERIMETER: 12.52 m

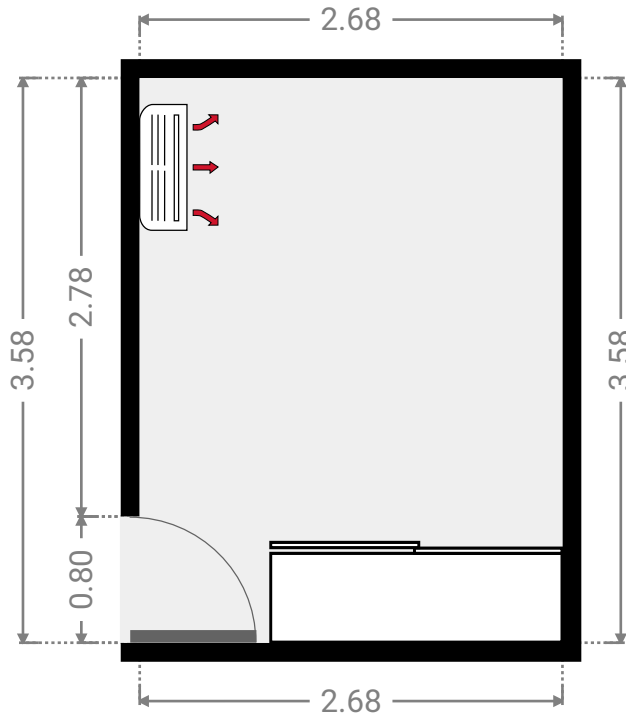

▼ **Bedroom**  
1st Floor

WIDTH: 3.71 m • LENGTH: 3.86 m  
AREA: 13.65 m<sup>2</sup> • PERIMETER: 15.14 m

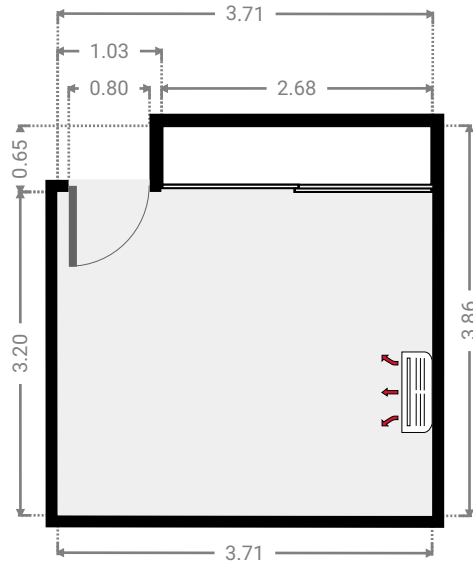
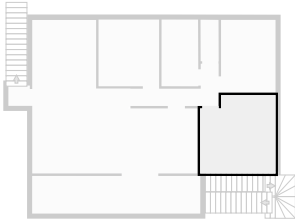

▼ **Other**  
1st Floor

WIDTH: 8.27 m • LENGTH: 1.85 m  
AREA: 15.30 m<sup>2</sup> • PERIMETER: 20.24 m

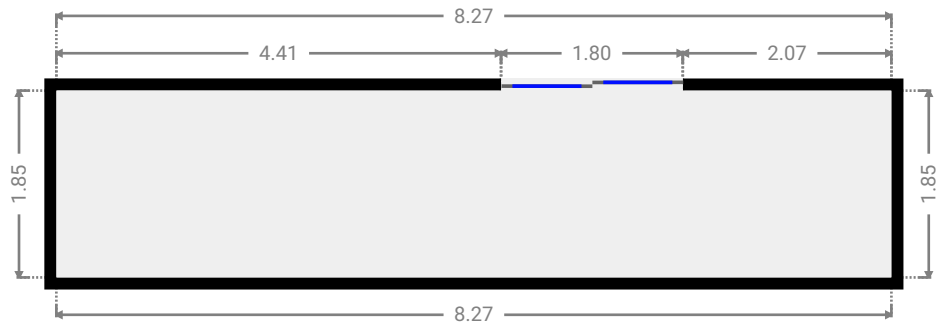
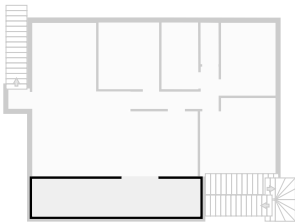

▼ Other  
1st Floor

WIDTH: 1.05 m • LENGTH: 1.00 m  
AREA: 1.05 m<sup>2</sup> • PERIMETER: 4.11 m

