

104 Stack Street

SUBMITTED BY

Ray White Rockhampton Casey
stockers@cqoz.com

CREATED ON

2022-08-02

Floors

2

▼ Ground Floor

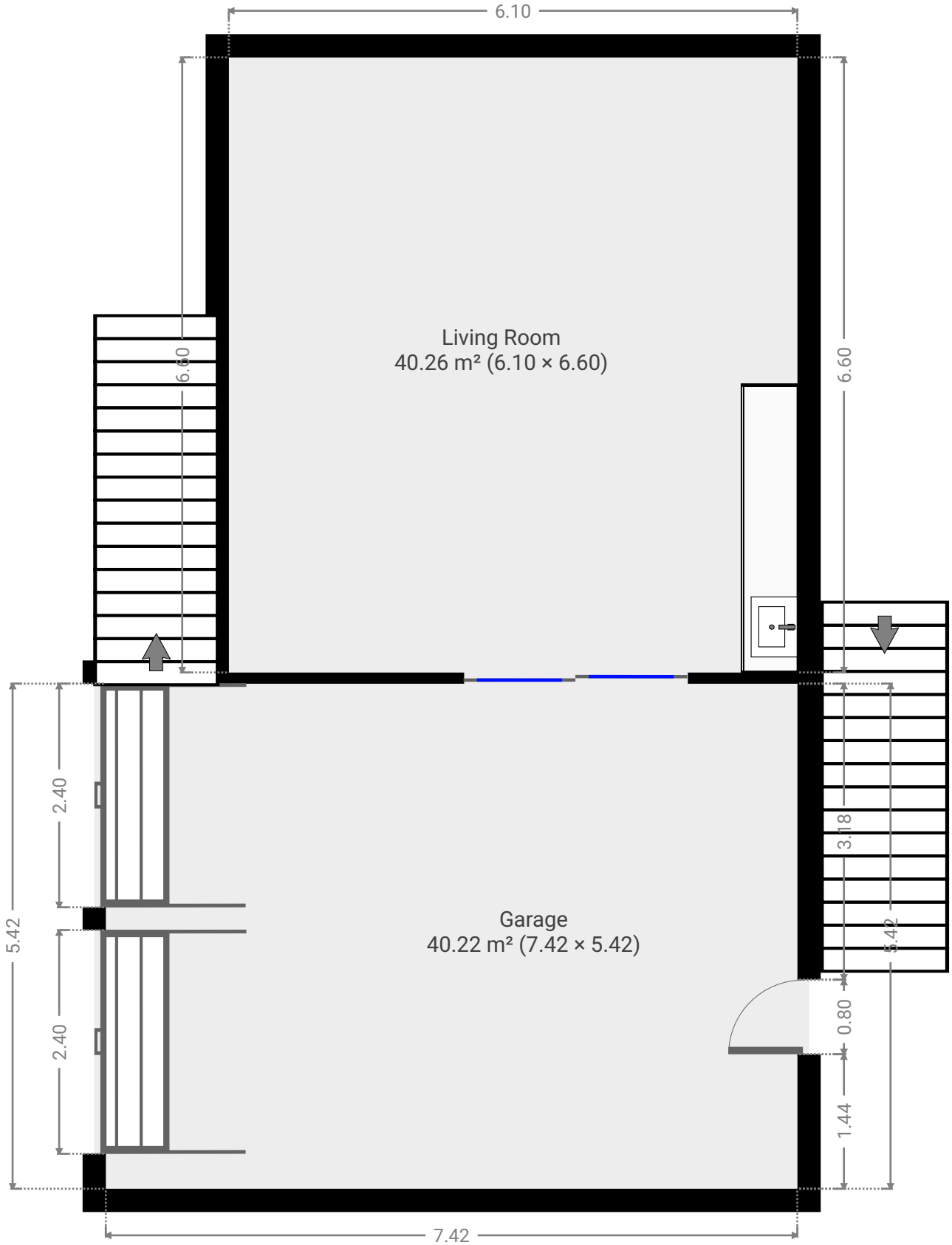

▼ **Garage**
Ground Floor

WIDTH: 5.42 m • LENGTH: 7.42 m
AREA: 40.22 m² • PERIMETER: 25.68 m

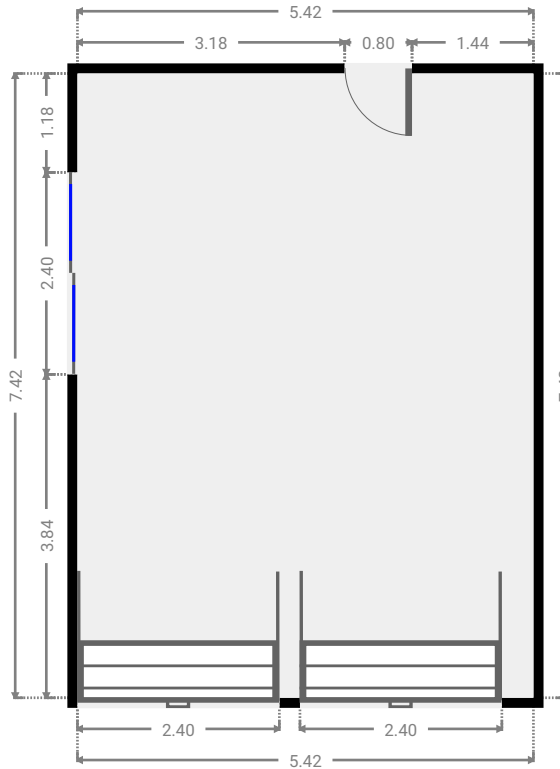
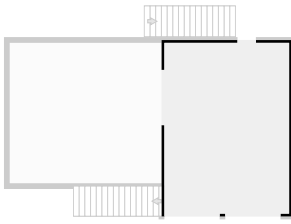

▼ **Living Room**
Ground Floor

WIDTH: 6.60 m • LENGTH: 6.10 m
AREA: 40.26 m² • PERIMETER: 25.40 m

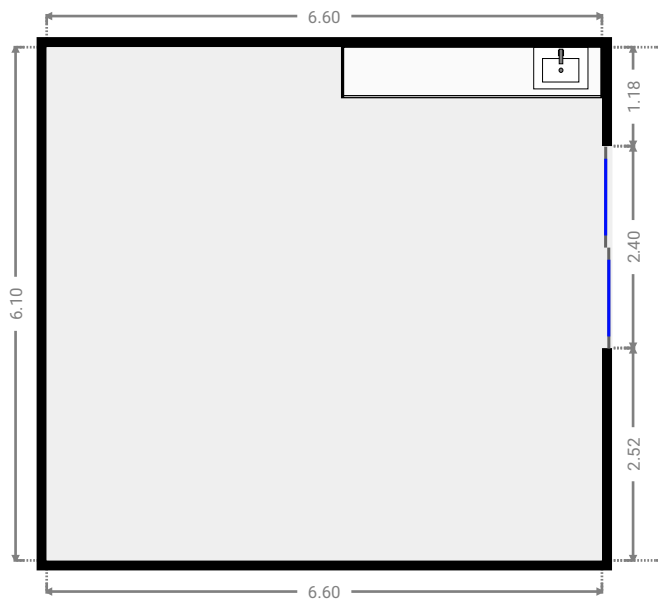
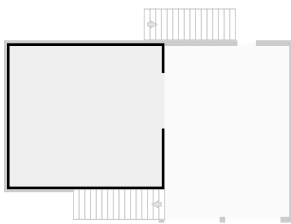

▼ 1st Floor

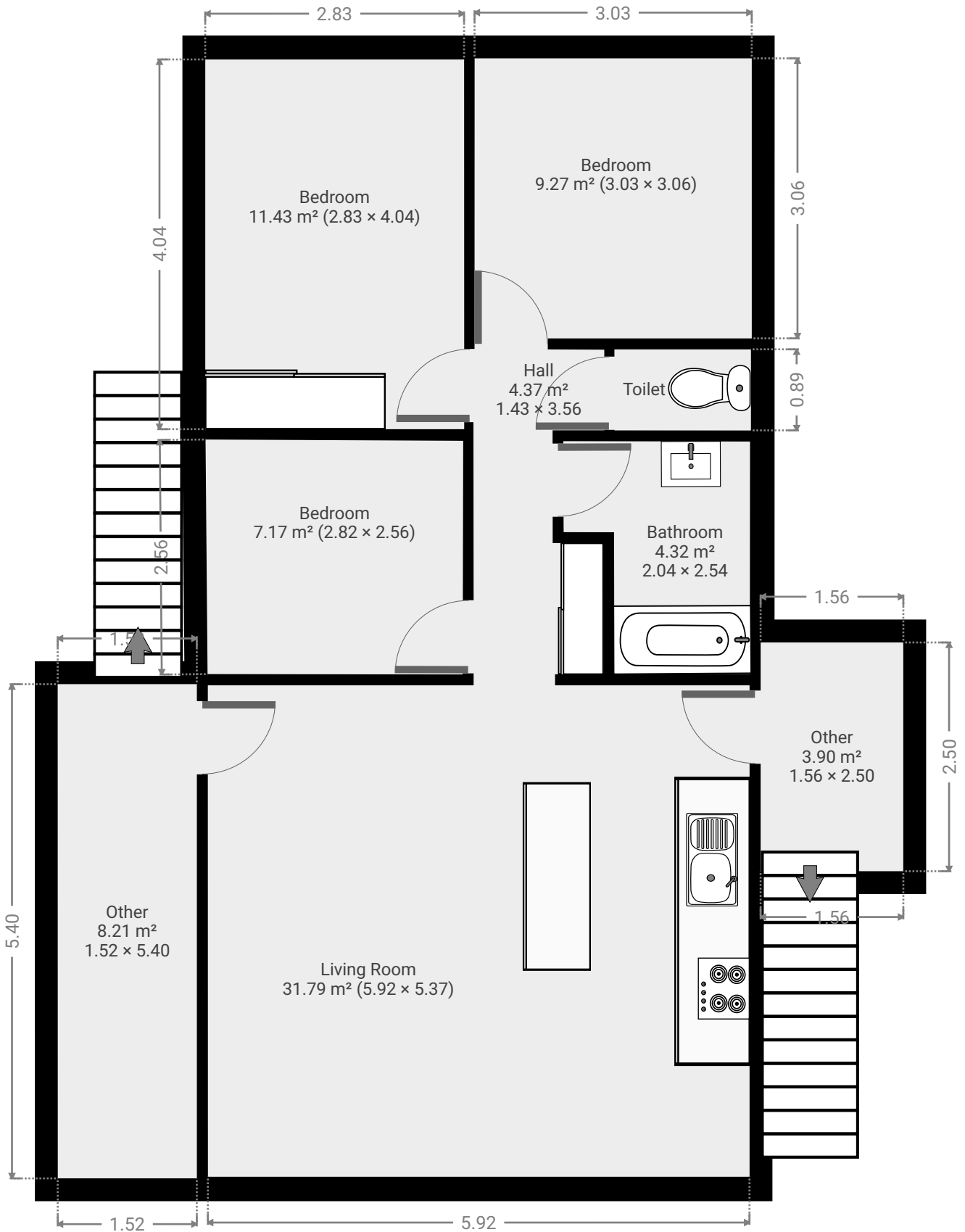

▼ Bathroom
1st Floor

WIDTH: 2.54 m • LENGTH: 2.04 m
AREA: 4.32 m² • PERIMETER: 9.16 m

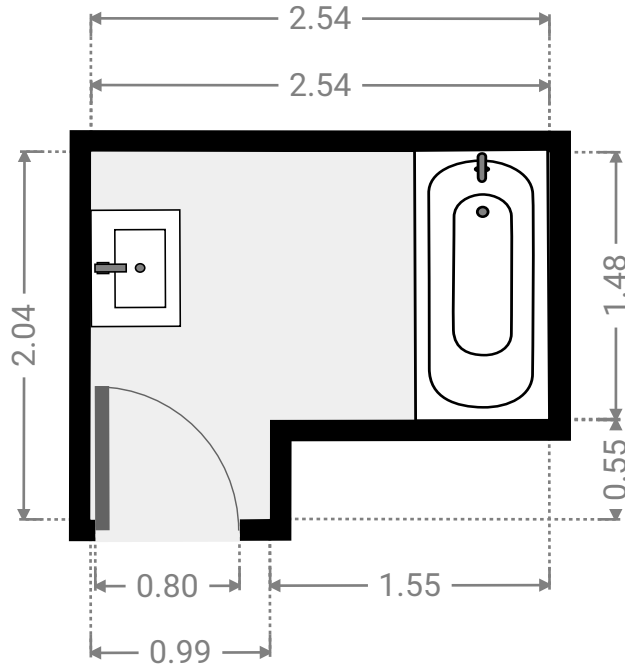
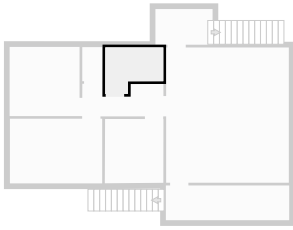

▼ Bedroom
1st Floor

WIDTH: 3.06 m • LENGTH: 3.03 m
AREA: 9.27 m² • PERIMETER: 12.18 m

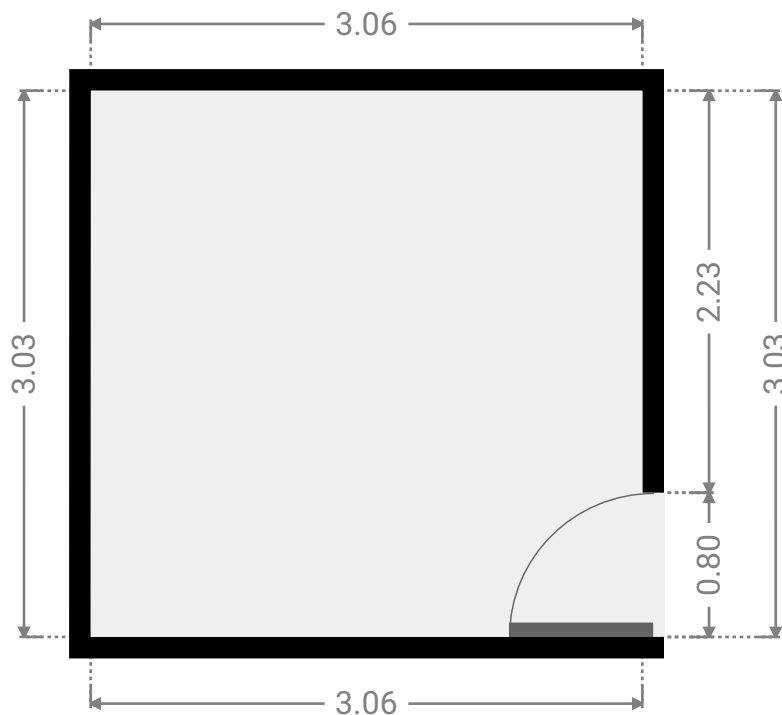
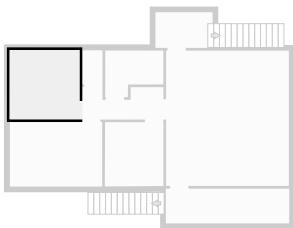

▼ **Bedroom**
1st Floor

WIDTH: 4.04 m • LENGTH: 2.83 m
AREA: 11.43 m² • PERIMETER: 13.74 m

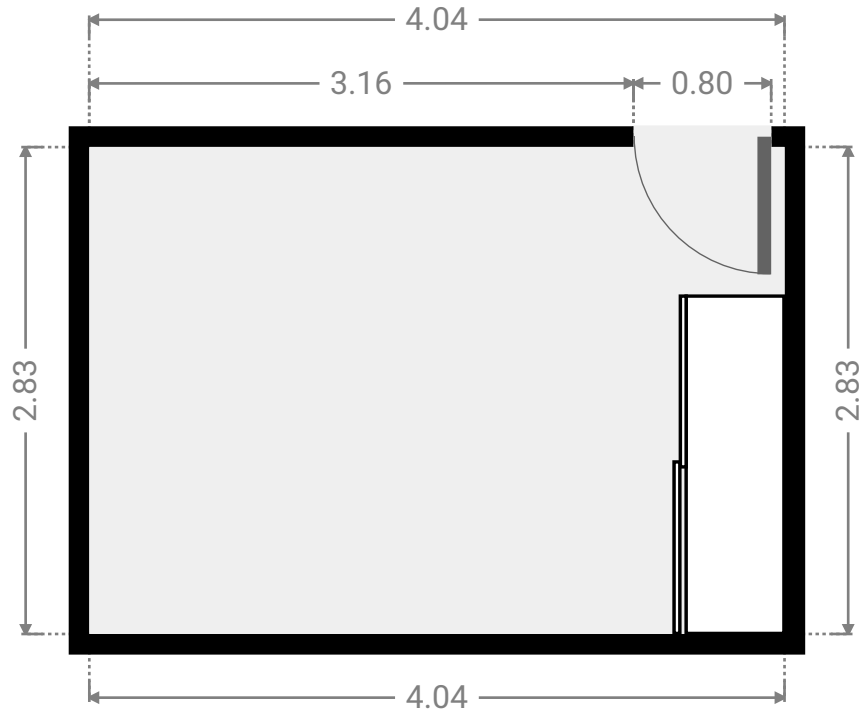
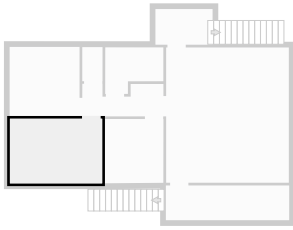

▼ **Bedroom**
1st Floor

WIDTH: 2.56 m • LENGTH: 2.82 m
AREA: 7.17 m² • PERIMETER: 10.72 m

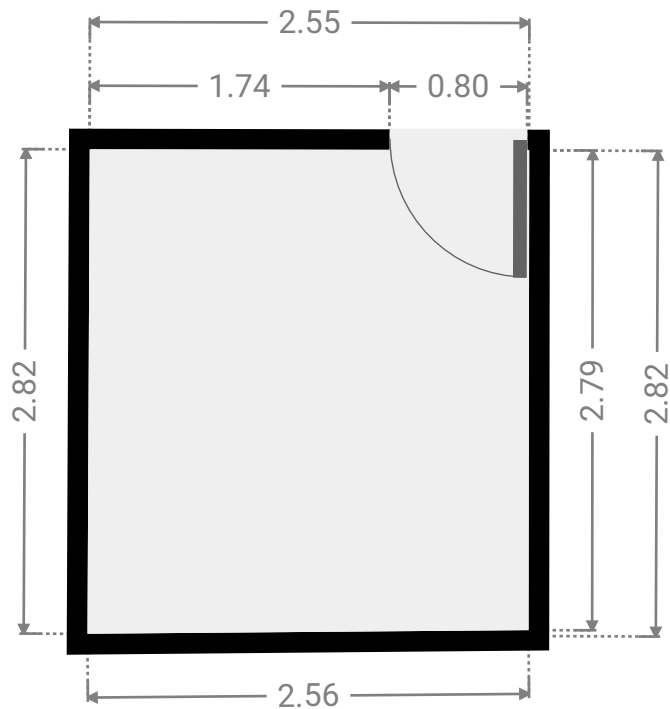
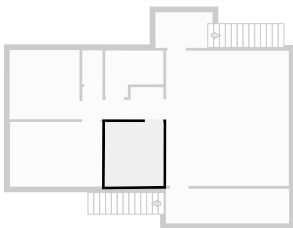

▼ **Hall**
1st Floor

WIDTH: 3.56 m • LENGTH: 1.43 m
AREA: 4.37 m² • PERIMETER: 11.07 m

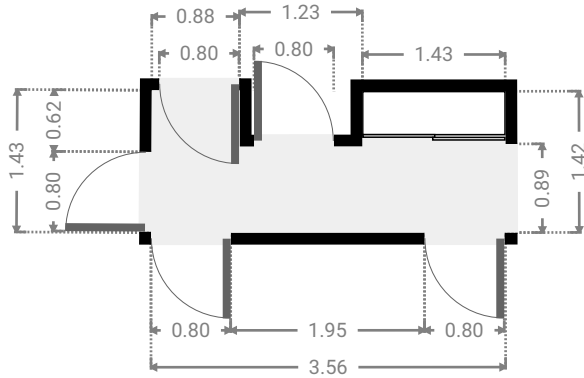
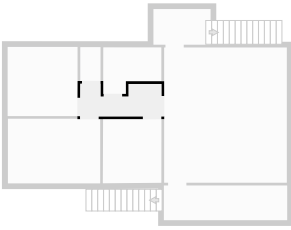

▼ **Living Room**
1st Floor

WIDTH: 5.37 m • LENGTH: 5.92 m
AREA: 31.79 m² • PERIMETER: 22.58 m

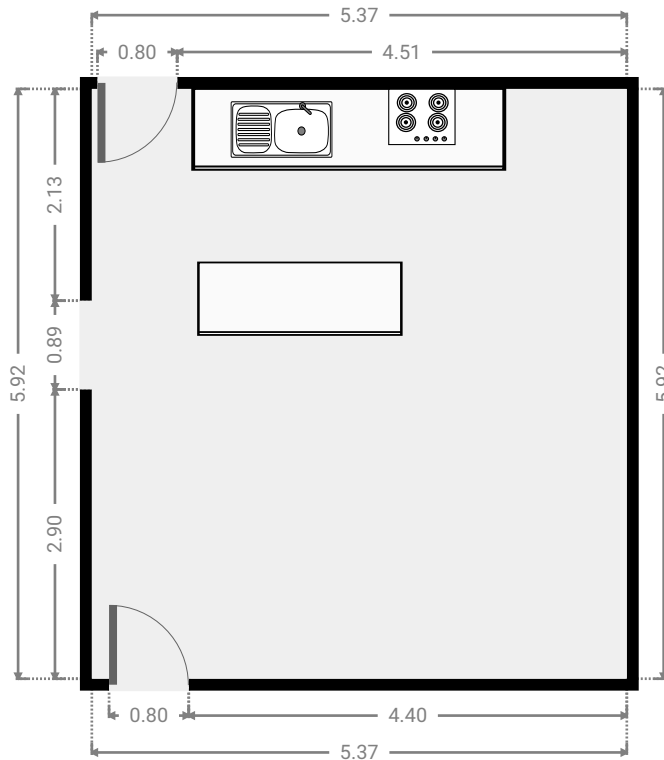
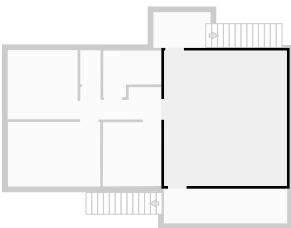

▼ Other
1st Floor

WIDTH: 2.50 m • LENGTH: 1.56 m
AREA: 3.90 m² • PERIMETER: 8.12 m

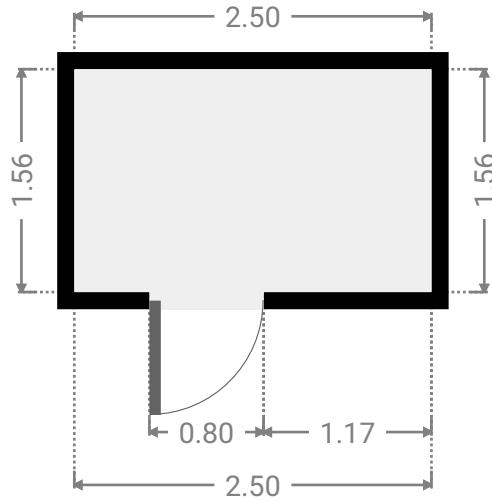
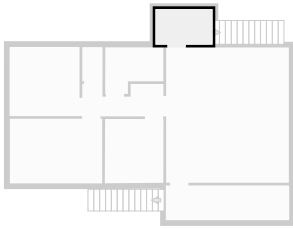

▼ Other
1st Floor

WIDTH: 5.40 m • LENGTH: 1.52 m
AREA: 8.21 m² • PERIMETER: 13.84 m

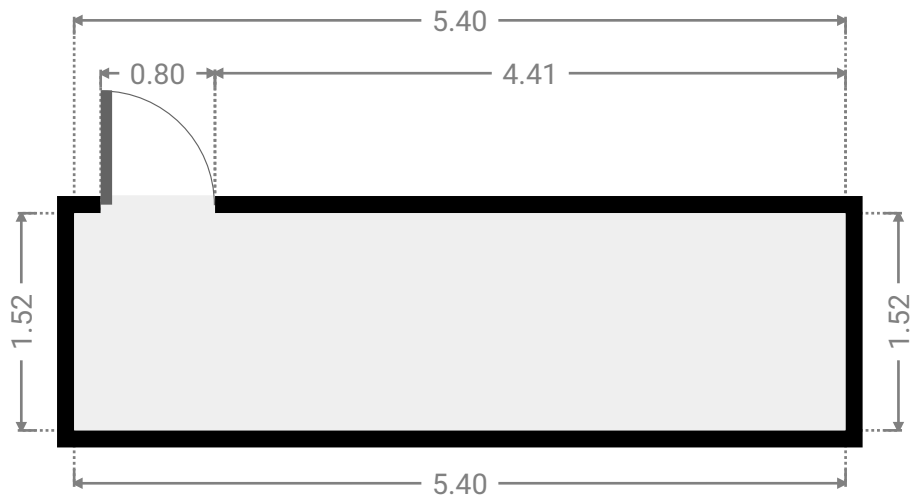
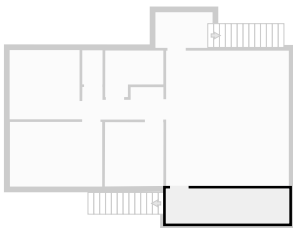

▼ Toilet
1st Floor

WIDTH: 0.89 m • LENGTH: 1.49 m
AREA: 1.32 m² • PERIMETER: 4.75 m

