

104 Robinson STREET

SUBMITTED BY

Ray White Rockhampton Casey
stockers@cqoz.com

CREATED ON

2022-09-28

Floors

2

▼ Ground Floor

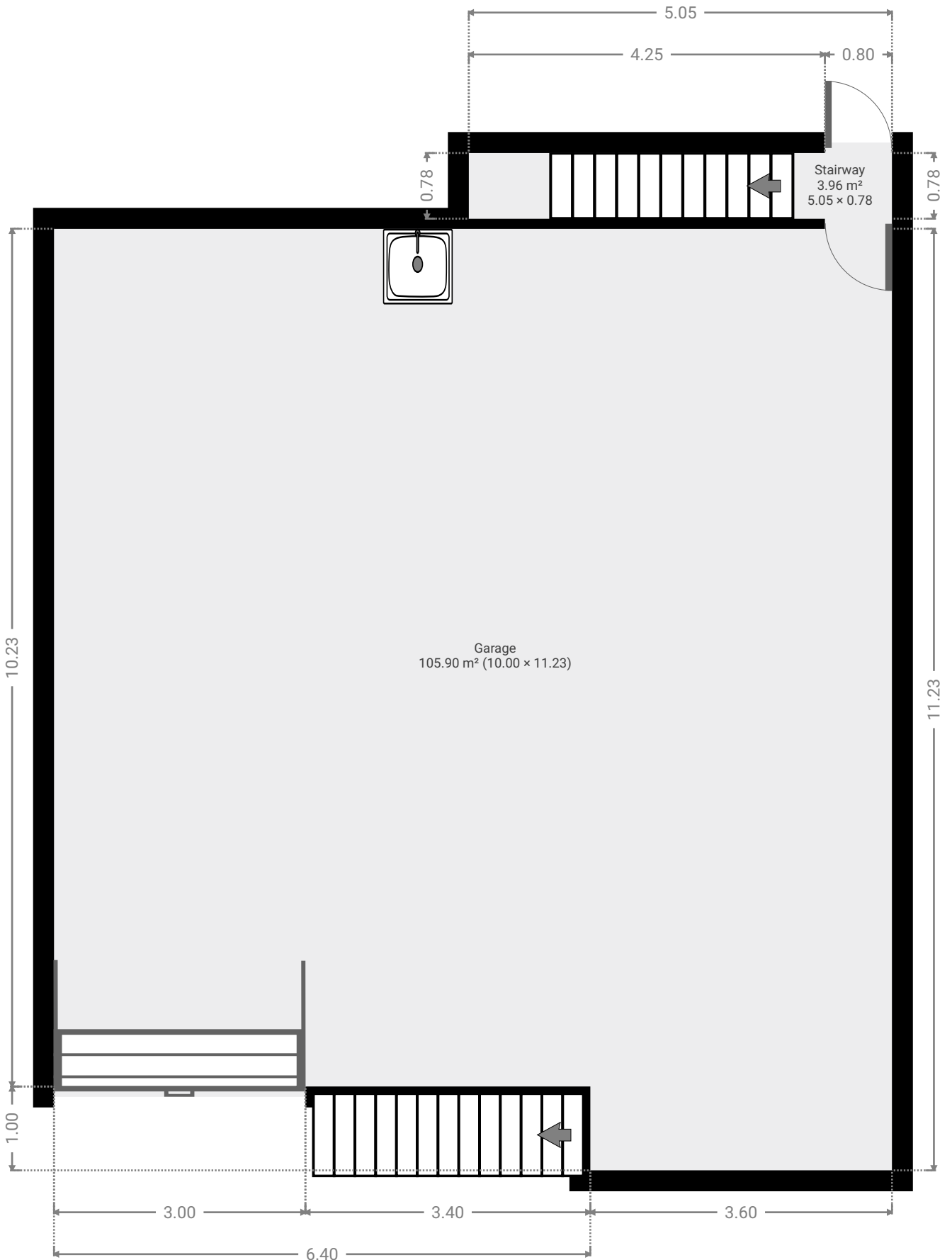

▼ **Garage**
Ground Floor

WIDTH: 10.00 m • LENGTH: 11.23 m
AREA: 105.90 m² • PERIMETER: 42.46 m

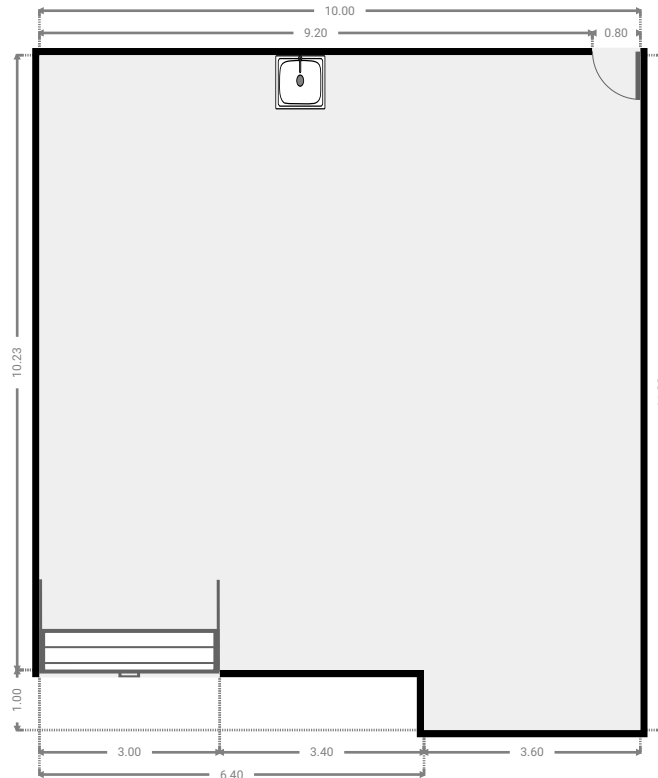
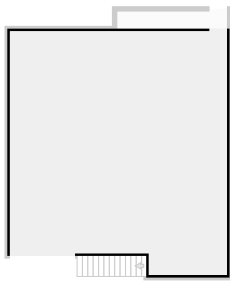

▼ **Stairway**
Ground Floor

WIDTH: 5.05 m • LENGTH: 0.78 m
AREA: 3.96 m² • PERIMETER: 11.67 m

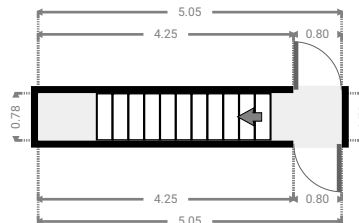
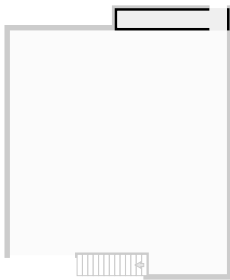

▼ 1st Floor

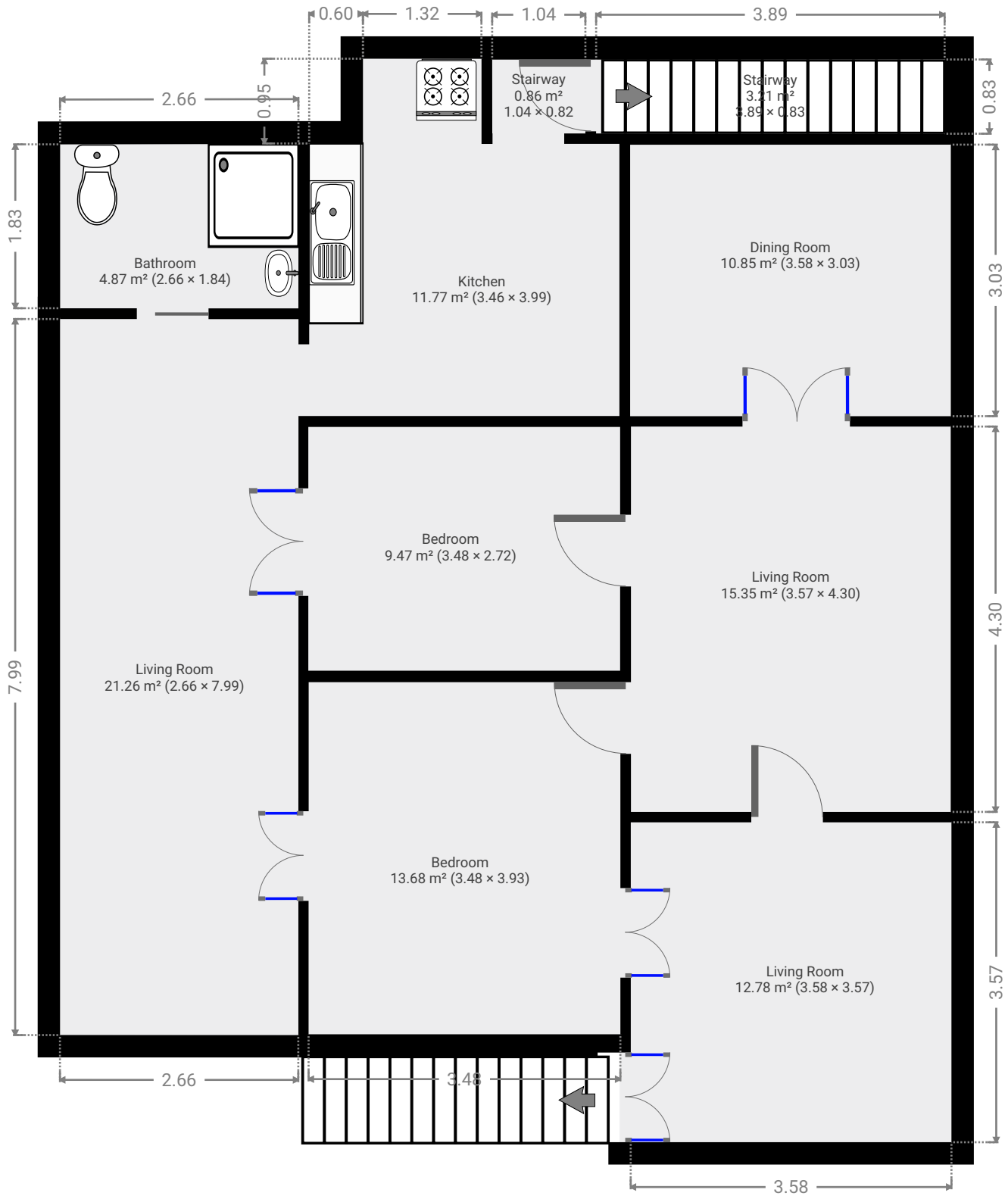

▼ **Bathroom**
1st Floor

WIDTH: 2.66 m • LENGTH: 1.84 m
AREA: 4.87 m² • PERIMETER: 8.98 m

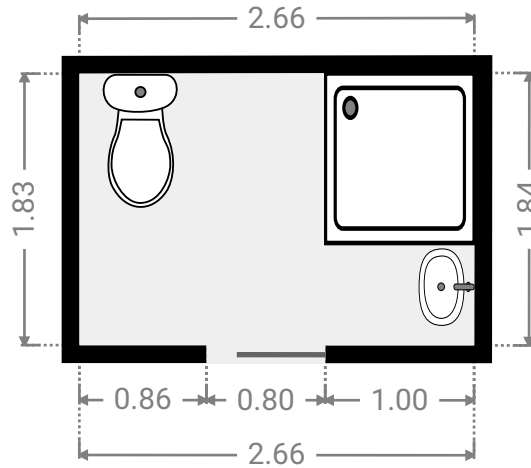
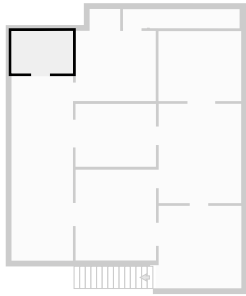

▼ **Bedroom**
1st Floor

WIDTH: 3.48 m • LENGTH: 3.93 m
AREA: 13.68 m² • PERIMETER: 14.82 m

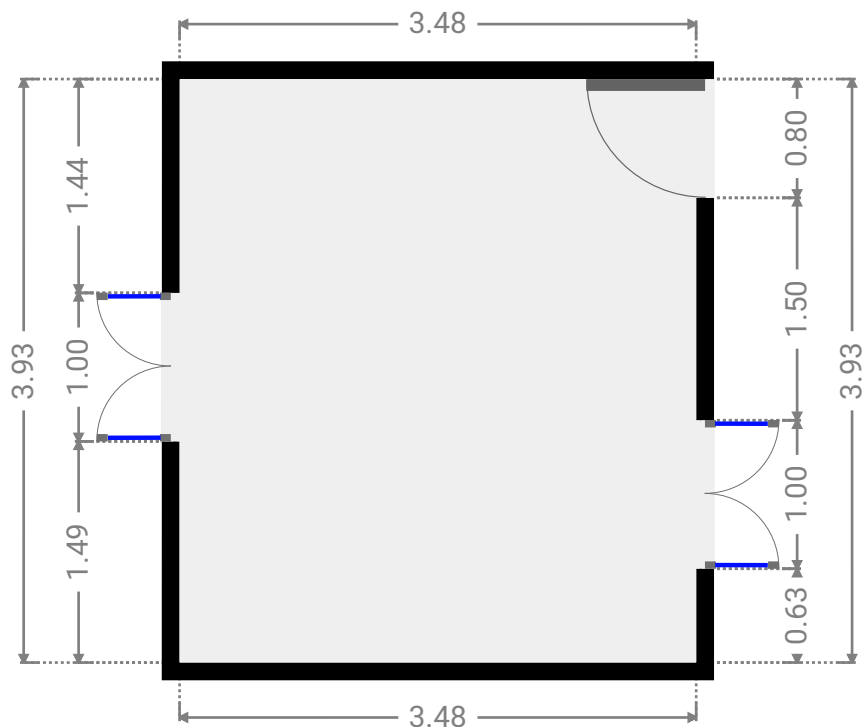
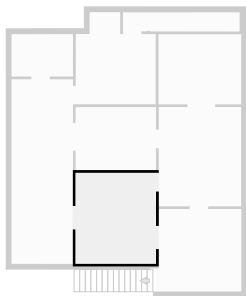

▼ **Bedroom**
1st Floor

WIDTH: 3.48 m • LENGTH: 2.72 m
AREA: 9.47 m² • PERIMETER: 12.40 m

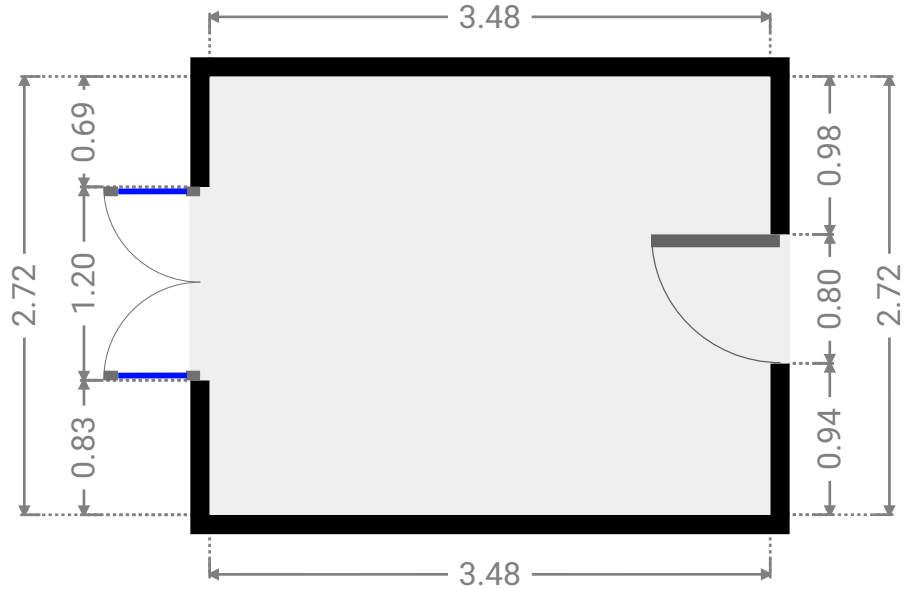
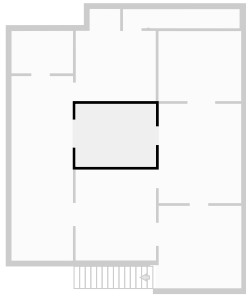

▼ **Dining Room**
1st Floor

WIDTH: 3.58 m • LENGTH: 3.03 m
AREA: 10.85 m² • PERIMETER: 13.22 m

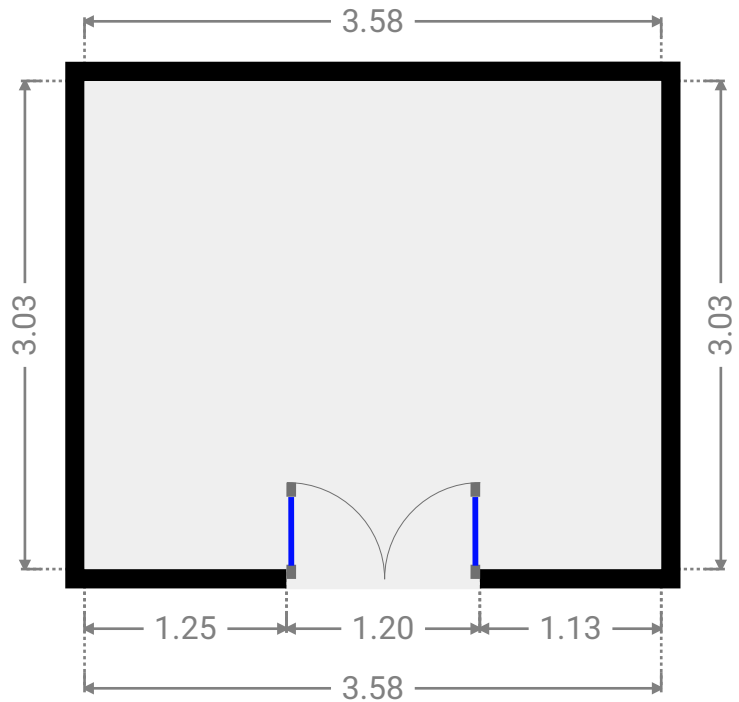
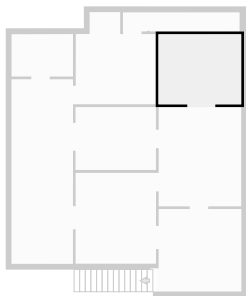

▼ **Kitchen**
1st Floor

WIDTH: 3.46 m • LENGTH: 3.99 m
AREA: 11.77 m² • PERIMETER: 14.90 m

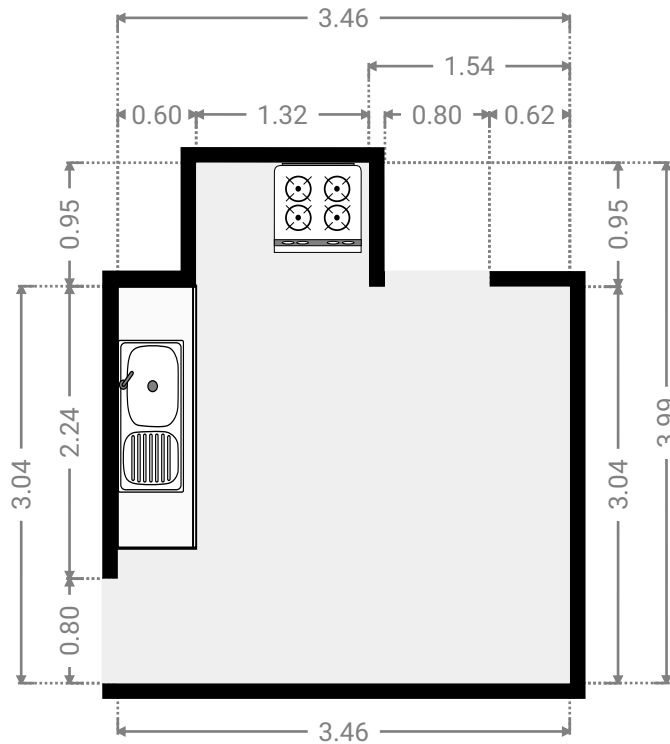
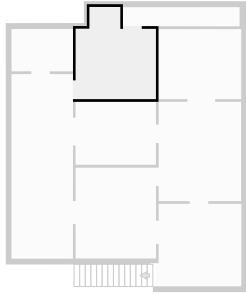

▼ **Living Room**
1st Floor

WIDTH: 3.58 m • LENGTH: 3.57 m
AREA: 12.78 m² • PERIMETER: 14.30 m

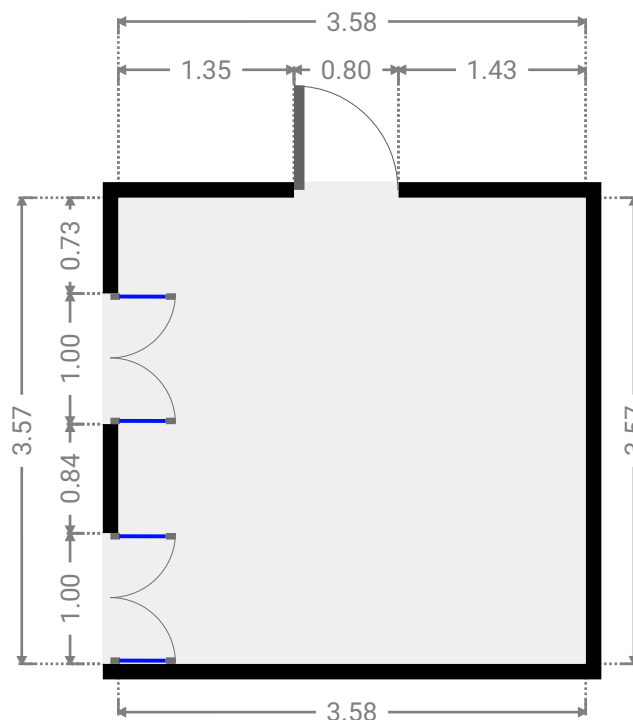
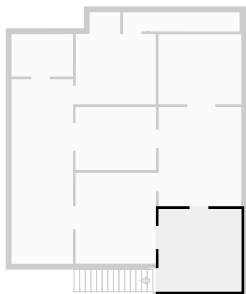

▼ **Living Room**
1st Floor

WIDTH: 2.66 m • LENGTH: 7.99 m
AREA: 21.26 m² • PERIMETER: 21.30 m

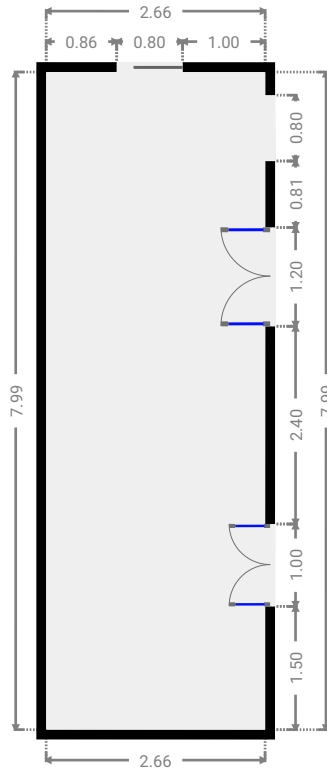
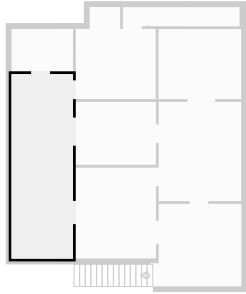

▼ **Living Room**
1st Floor

WIDTH: 3.57 m • LENGTH: 4.30 m
AREA: 15.35 m² • PERIMETER: 15.74 m

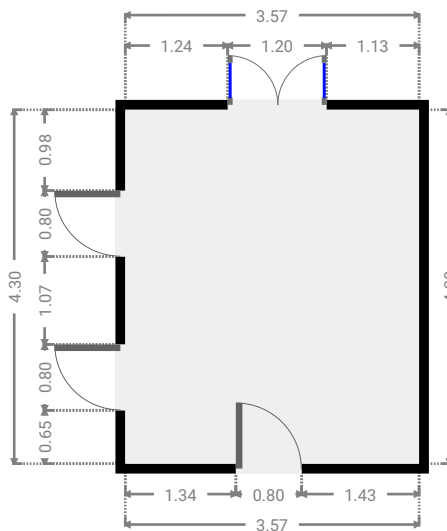
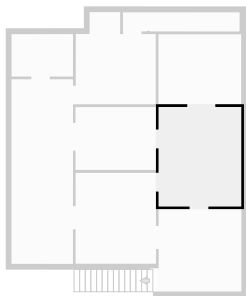

▼ **Stairway**
1st Floor

WIDTH: 3.89 m • LENGTH: 0.83 m
AREA: 3.21 m² • PERIMETER: 9.43 m

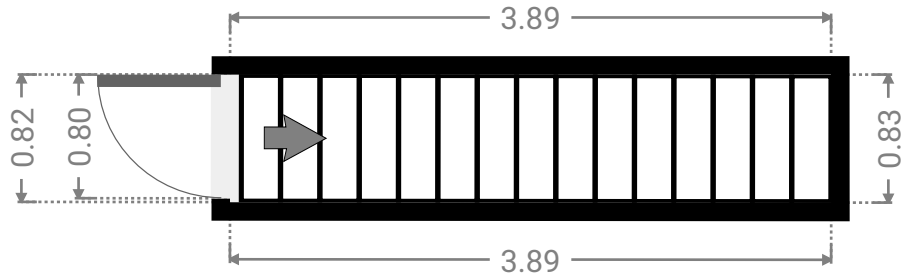
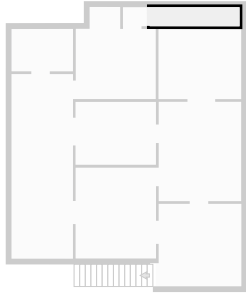

▼ **Stairway**
1st Floor

WIDTH: 1.04 m • LENGTH: 0.82 m
AREA: 0.86 m² • PERIMETER: 3.73 m

