

103 Stamford Street

SUBMITTED BY

Ray White Rockhampton Casey
stockers@cqoz.com

CREATED ON

2022-08-09

Floors

2

▼ Ground Floor

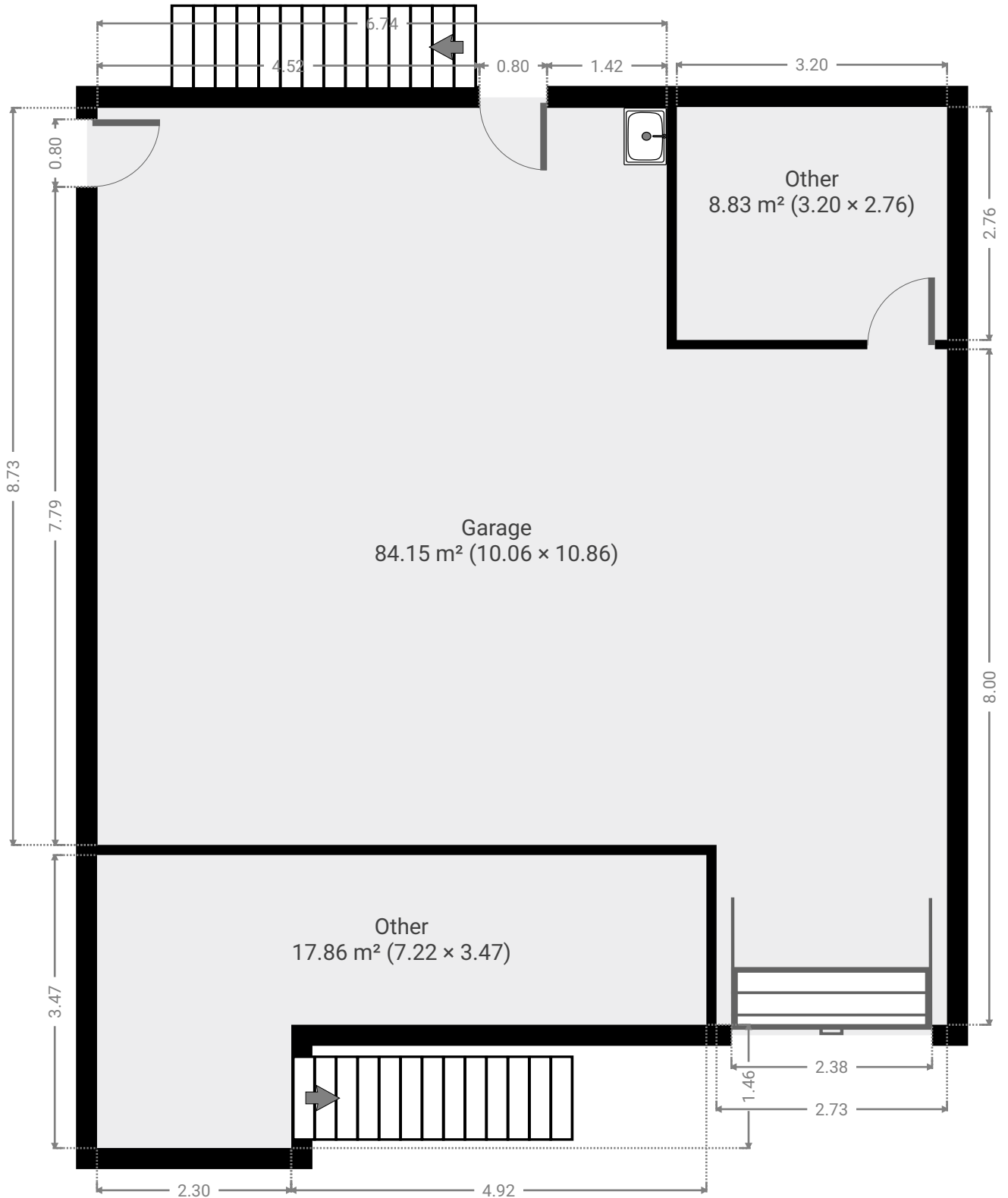

FLOORS: 2

▼ Garage
Ground Floor

WIDTH: 10.06 m • LENGTH: 10.86 m
AREA: 84.15 m² • PERIMETER: 41.84 m

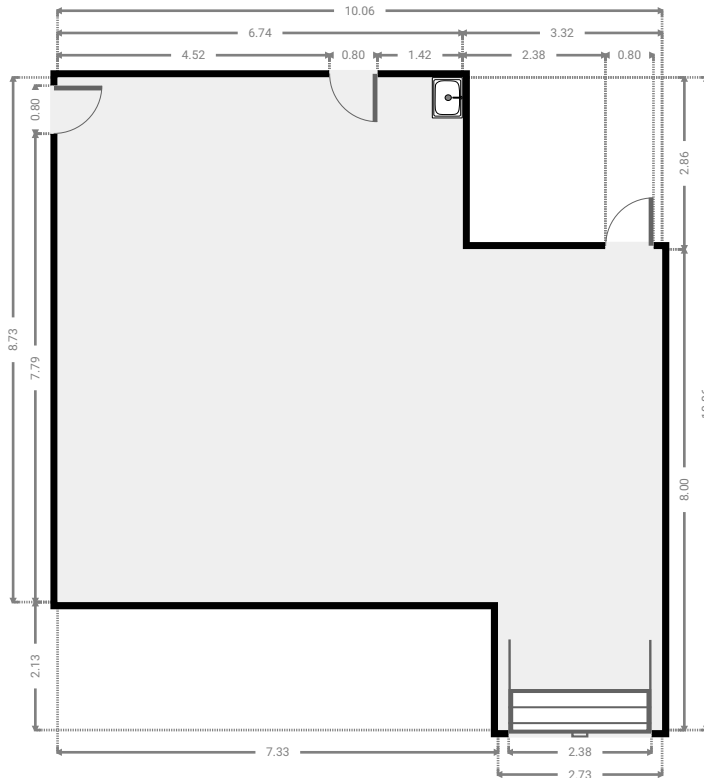
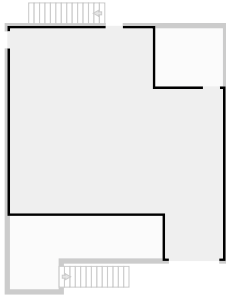

▼ Other
Ground Floor

WIDTH: 3.20 m • LENGTH: 2.76 m
AREA: 8.83 m² • PERIMETER: 11.92 m

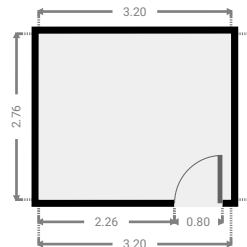
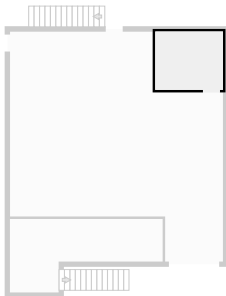

▼ Other
Ground Floor

WIDTH: 7.22 m • LENGTH: 3.47 m
AREA: 17.86 m² • PERIMETER: 21.37 m

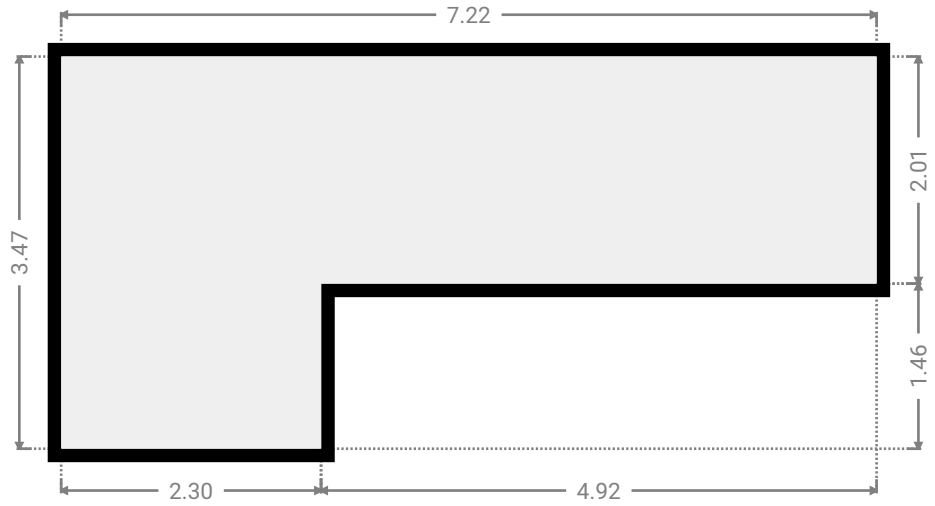
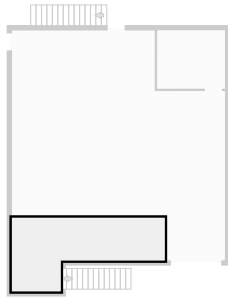

▼ 1st Floor

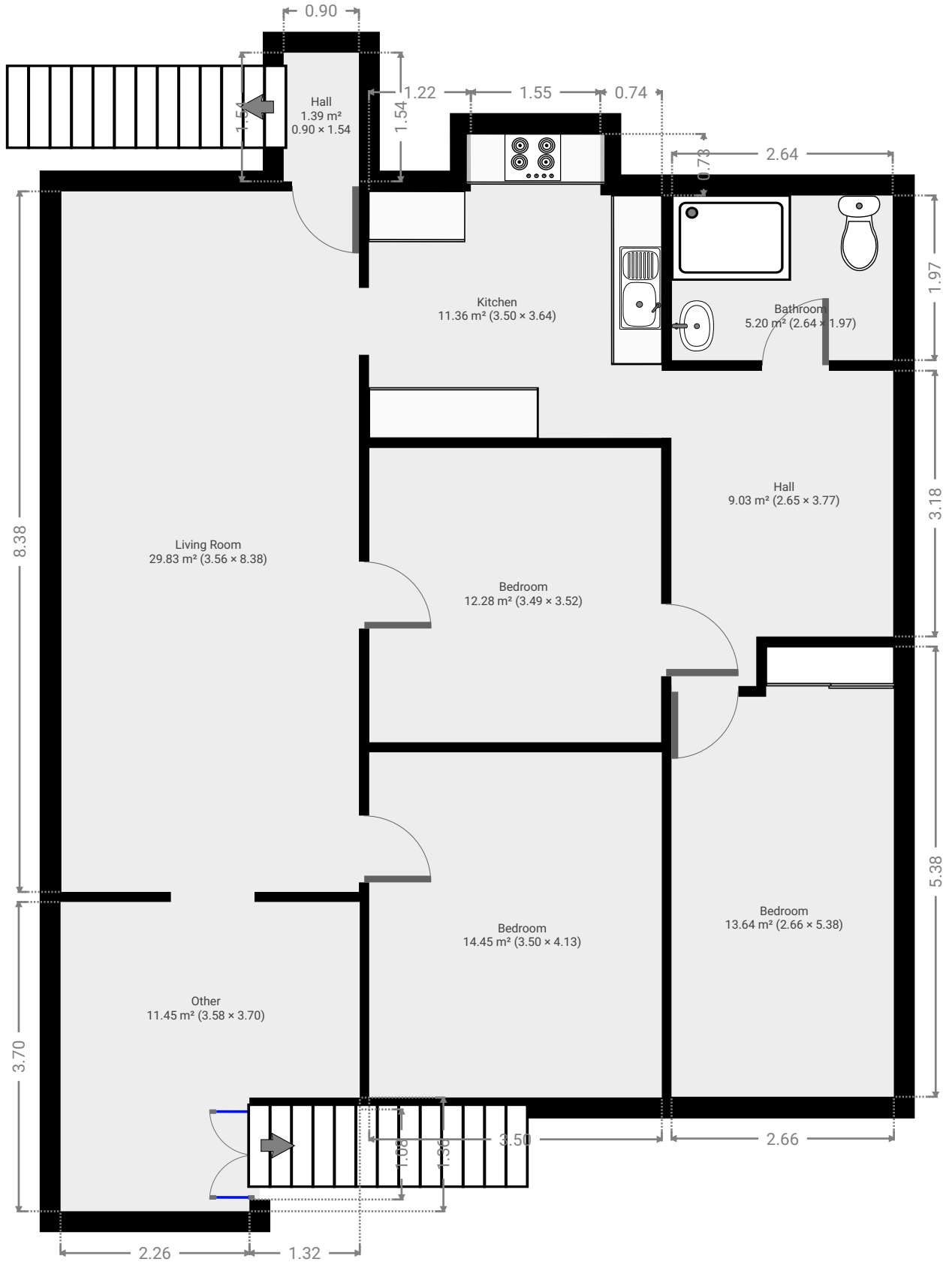

▼ Bathroom
1st Floor

WIDTH: 2.64 m • LENGTH: 1.97 m
AREA: 5.20 m² • PERIMETER: 9.22 m

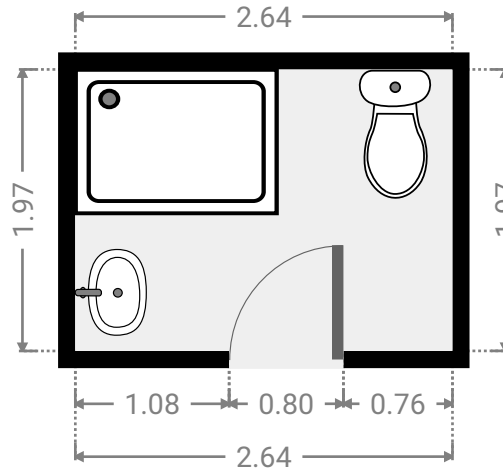
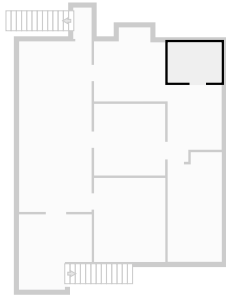

▼ Bedroom
1st Floor

WIDTH: 3.50 m • LENGTH: 4.13 m
AREA: 14.45 m² • PERIMETER: 15.26 m

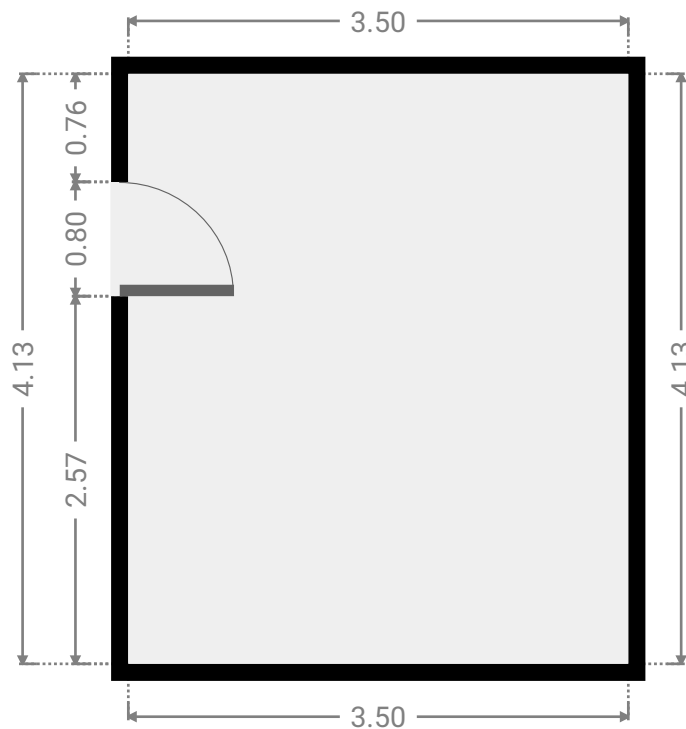
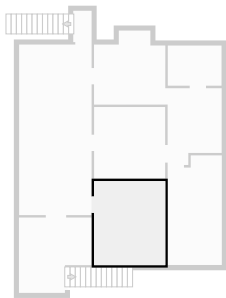

▼ Bedroom
1st Floor

WIDTH: 3.49 m • LENGTH: 3.52 m
AREA: 12.28 m² • PERIMETER: 14.02 m

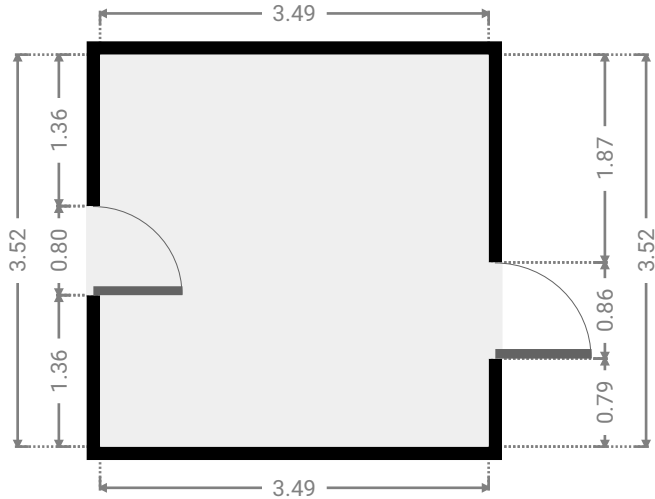
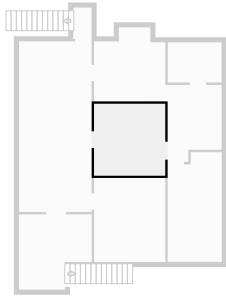

▼ Bedroom
1st Floor

WIDTH: 2.66 m • LENGTH: 5.38 m
AREA: 13.64 m² • PERIMETER: 16.09 m

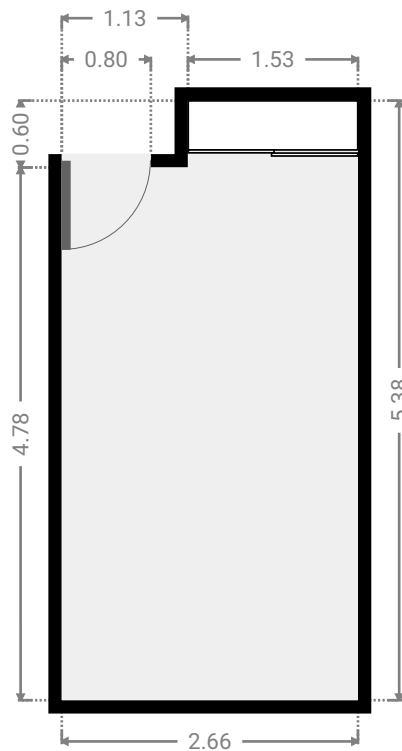
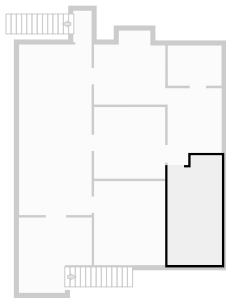

▼ **Hall**
1st Floor

WIDTH: 2.65 m • LENGTH: 3.77 m
AREA: 9.03 m² • PERIMETER: 12.85 m

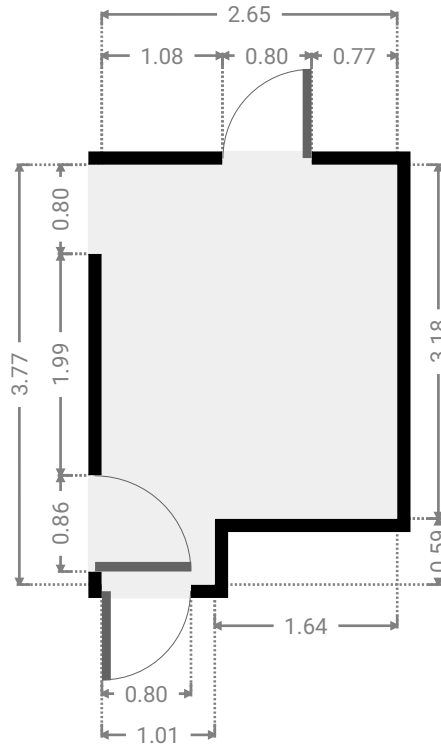
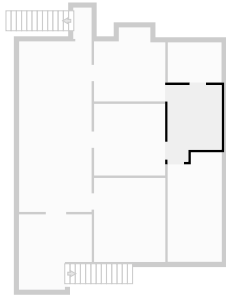

▼ **Hall**
1st Floor

WIDTH: 0.90 m • LENGTH: 1.54 m
AREA: 1.39 m² • PERIMETER: 4.88 m

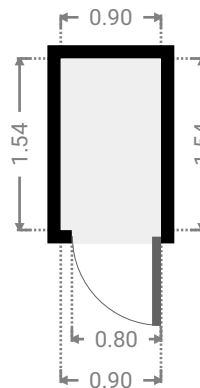
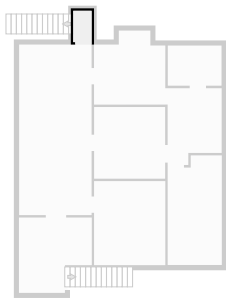

▼ **Kitchen**
1st Floor

WIDTH: 3.50 m • LENGTH: 3.64 m
AREA: 11.36 m² • PERIMETER: 14.28 m

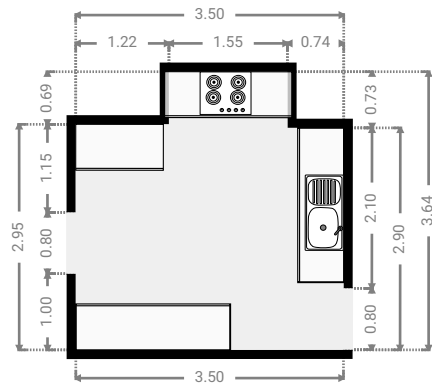
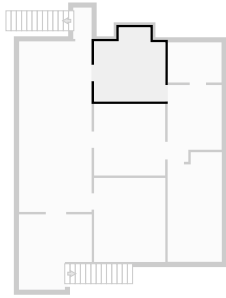

▼ **Living Room**
1st Floor

WIDTH: 3.56 m • LENGTH: 8.38 m
AREA: 29.83 m² • PERIMETER: 23.88 m

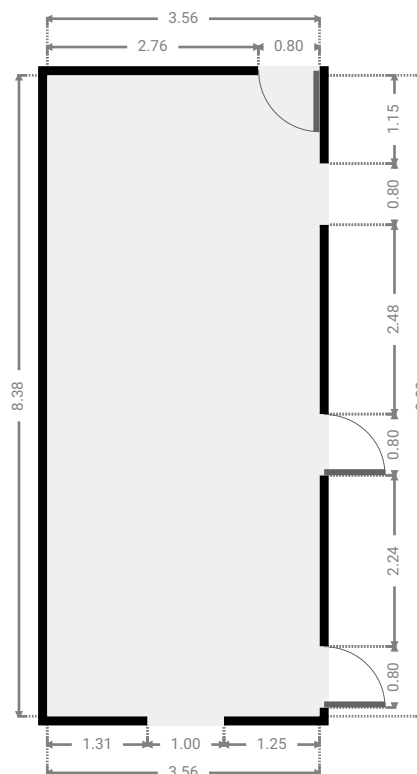
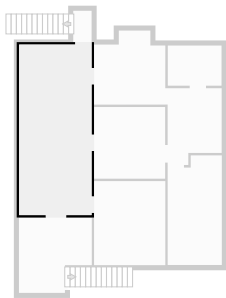

▼ Other
1st Floor

WIDTH: 3.58 m • LENGTH: 3.70 m
AREA: 11.45 m² • PERIMETER: 14.56 m

