

# 101 Dendle Road Milman

**SUBMITTED BY**

Ray White Rockhampton Casey  
stockers@cqoz.com

---

**CREATED ON**

2022-05-25

---

**Floors**

2

---

▼ Ground Floor

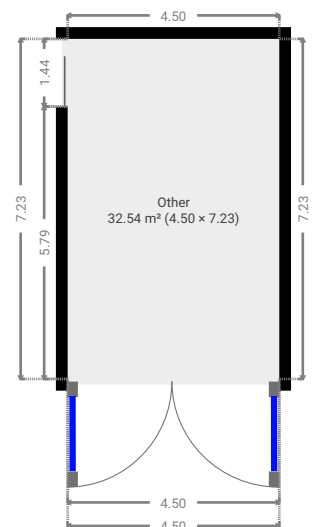
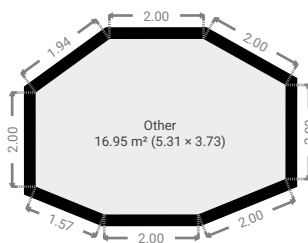
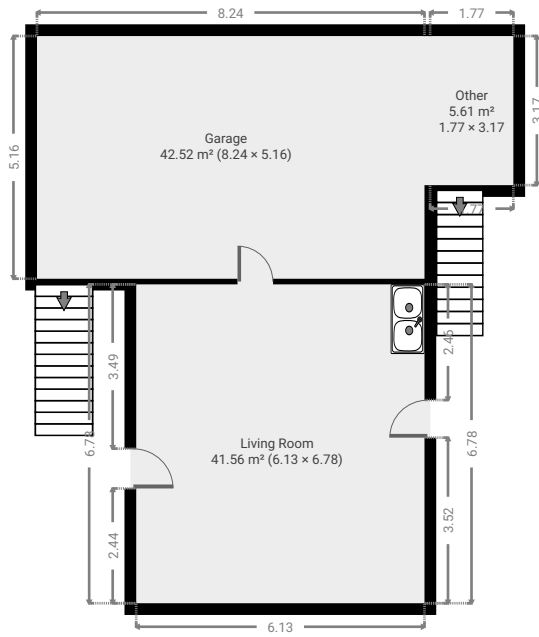
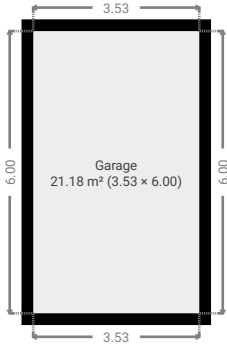

FLOORS: 2

▼ **Garage**  
Ground Floor

WIDTH: 5.16 m • LENGTH: 8.24 m  
AREA: 42.52 m<sup>2</sup> • PERIMETER: 26.80 m

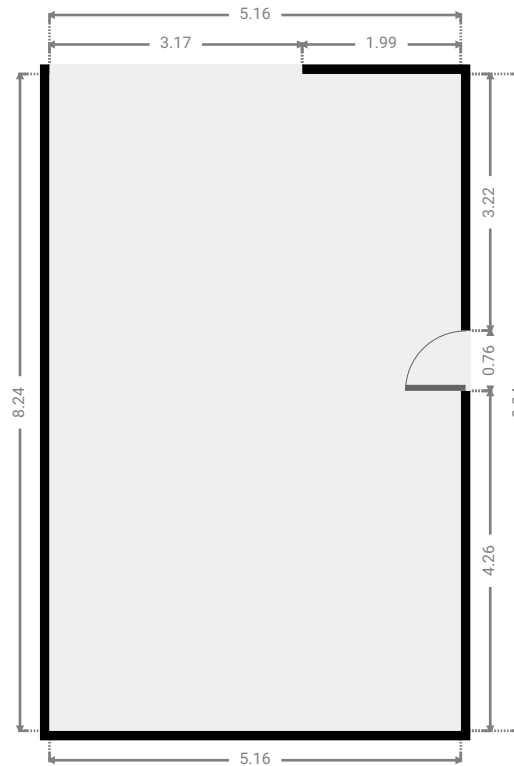
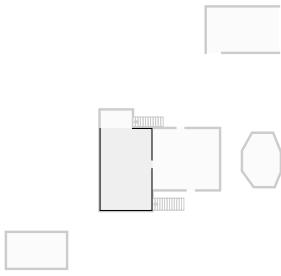

▼ **Garage**  
Ground Floor

WIDTH: 6.00 m • LENGTH: 3.53 m  
AREA: 21.18 m<sup>2</sup> • PERIMETER: 19.06 m

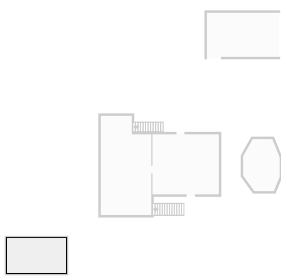

▼ **Living Room**  
Ground Floor

WIDTH: 6.78 m • LENGTH: 6.13 m  
AREA: 41.56 m<sup>2</sup> • PERIMETER: 25.82 m

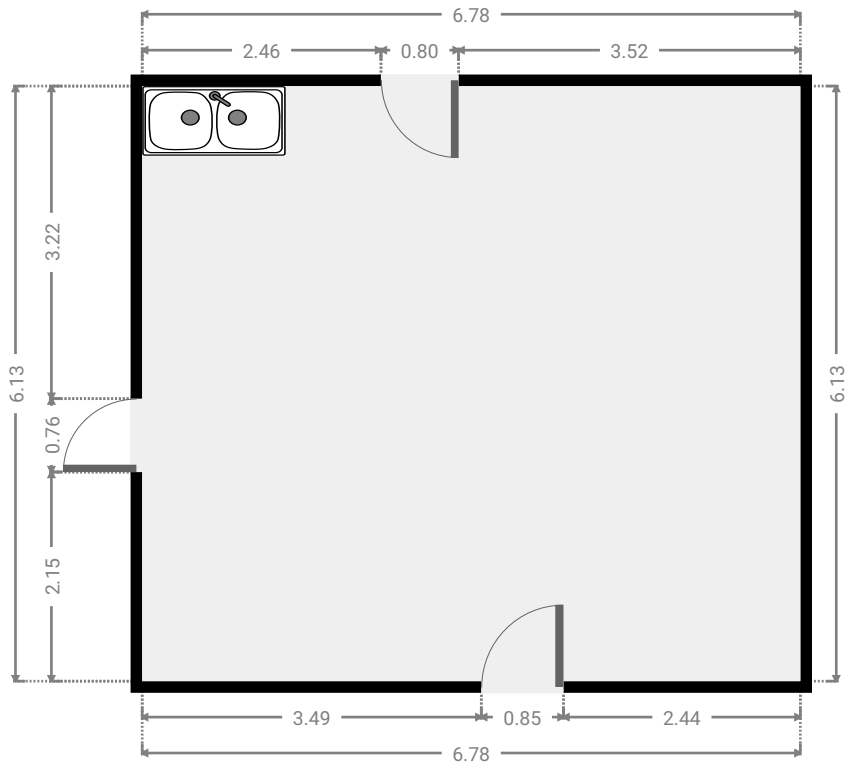
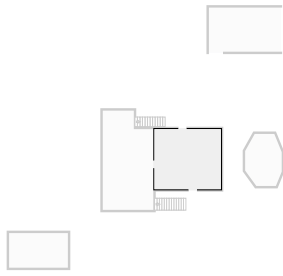

▼ **Other**  
Ground Floor

WIDTH: 3.17 m • LENGTH: 1.77 m  
AREA: 5.61 m<sup>2</sup> • PERIMETER: 9.88 m

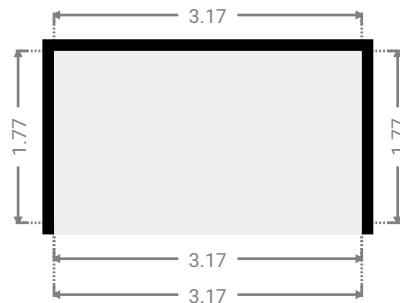
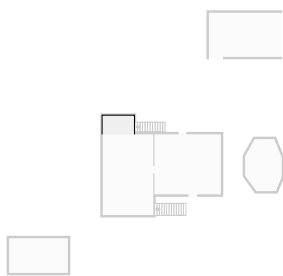

FLOORS: 2

▼ **Other**  
Ground Floor

WIDTH: 7.23 m • LENGTH: 4.50 m  
AREA: 32.54 m<sup>2</sup> • PERIMETER: 23.46 m

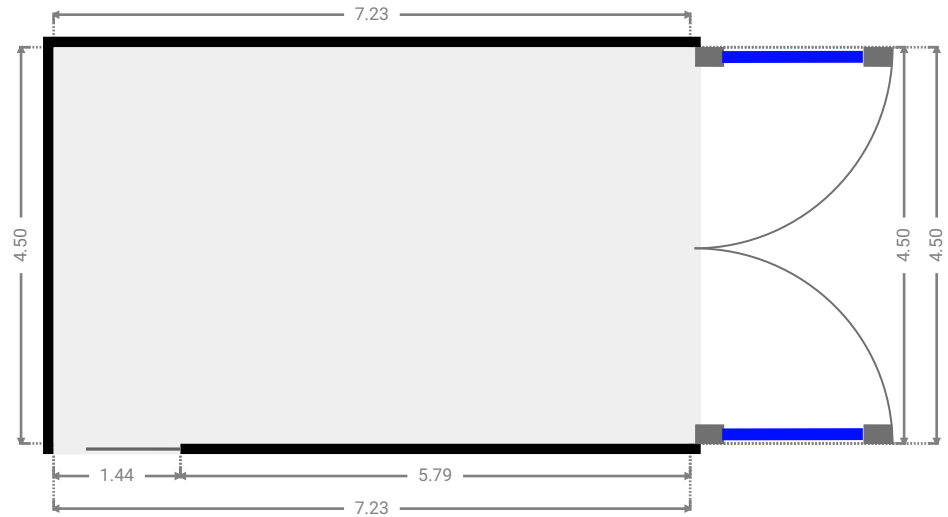
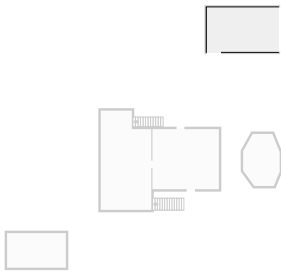

▼ **Other**  
Ground Floor

WIDTH: 3.73 m • LENGTH: 5.31 m  
AREA: 16.95 m<sup>2</sup> • PERIMETER: 15.51 m

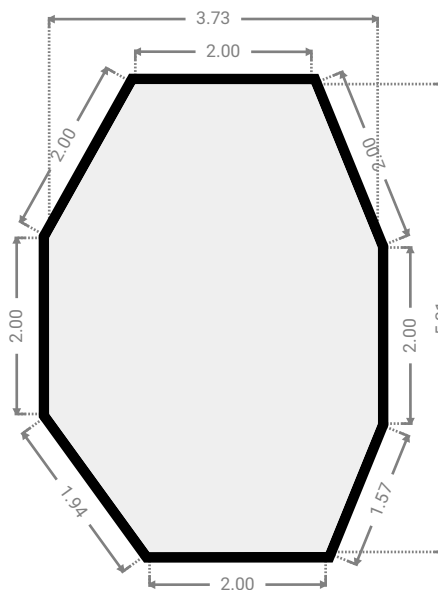
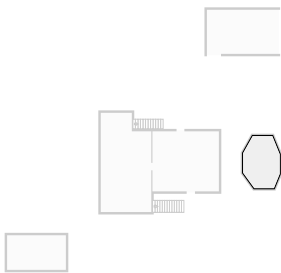

## ▼ 1st Floor

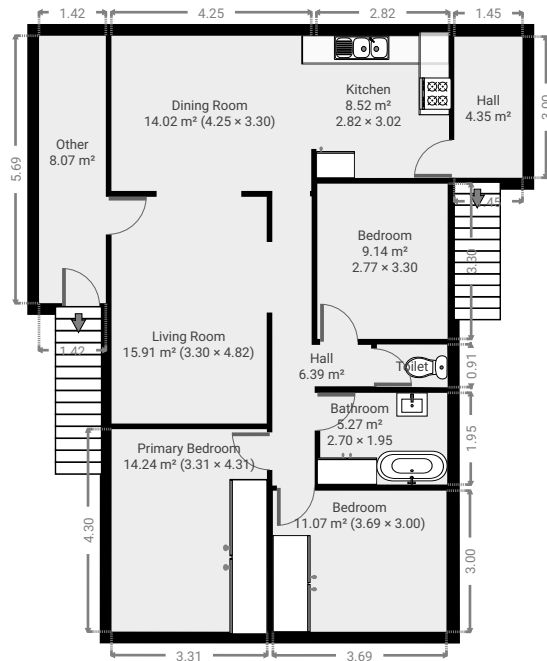

▼ **Bathroom**  
1st Floor

WIDTH: 1.95 m • LENGTH: 2.70 m  
AREA: 5.27 m<sup>2</sup> • PERIMETER: 9.30 m

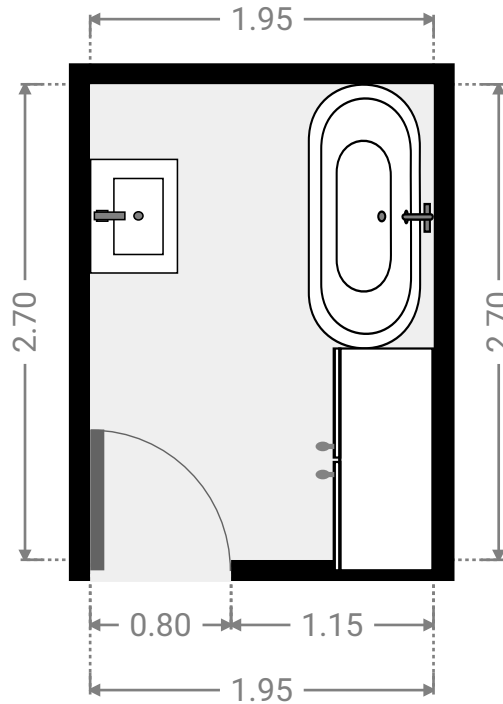
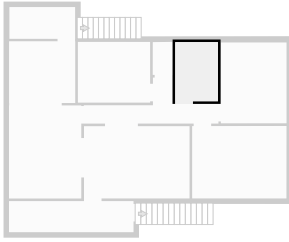

▼ **Bedroom**  
1st Floor

WIDTH: 3.30 m • LENGTH: 2.77 m  
AREA: 9.14 m<sup>2</sup> • PERIMETER: 12.14 m

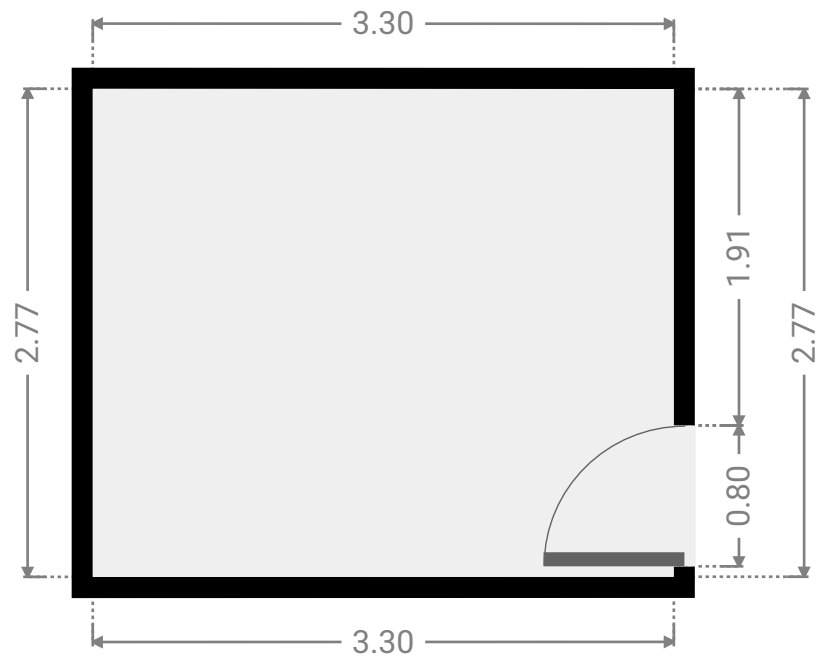
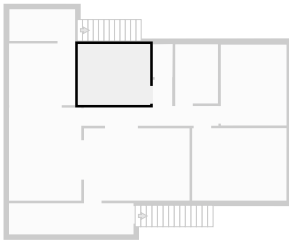

▼ **Bedroom**  
1st Floor

WIDTH: 3.00 m • LENGTH: 3.69 m  
AREA: 11.07 m<sup>2</sup> • PERIMETER: 13.38 m

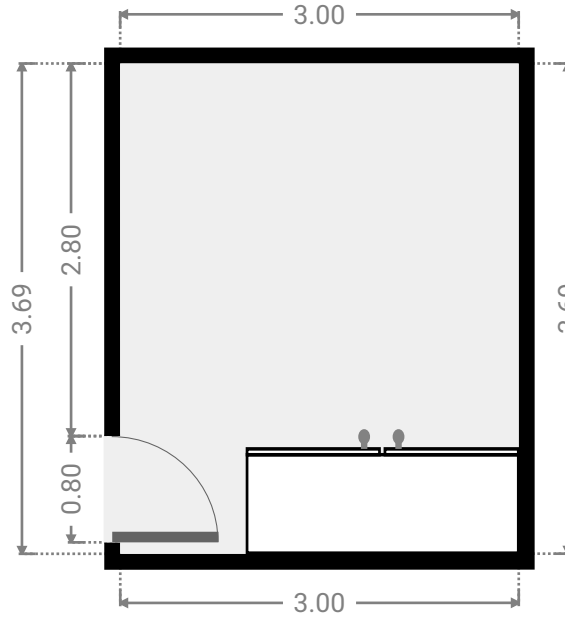
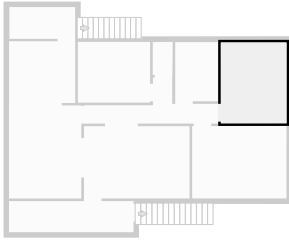

▼ **Dining Room**  
1st Floor

WIDTH: 3.30 m • LENGTH: 4.25 m  
AREA: 14.02 m<sup>2</sup> • PERIMETER: 15.10 m

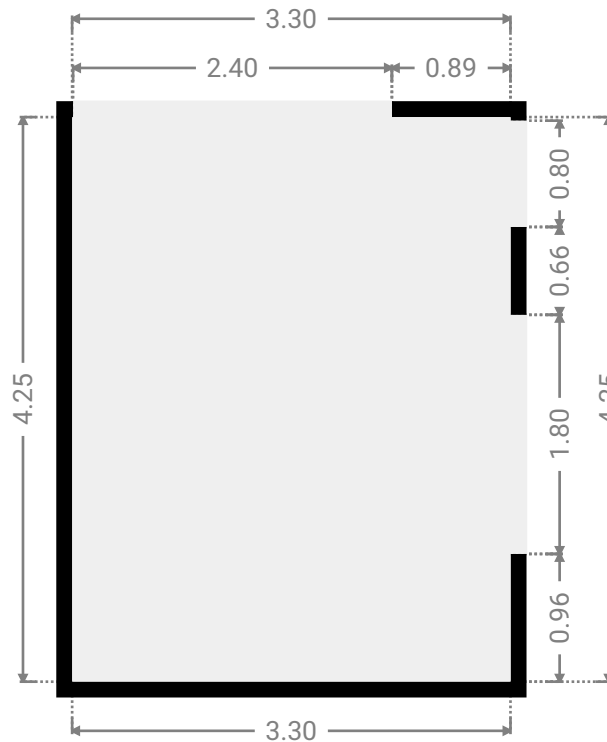



▼ **Hall**  
1st Floor

WIDTH: 6.15 m • LENGTH: 2.10 m  
AREA: 6.39 m<sup>2</sup> • PERIMETER: 16.50 m

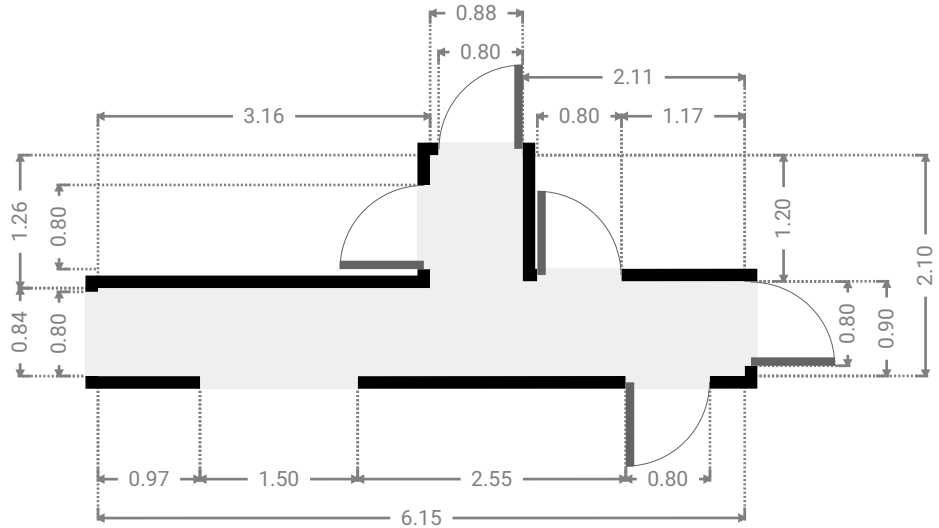

▼ **Hall**  
1st Floor

WIDTH: 3.00 m • LENGTH: 1.45 m  
AREA: 4.35 m<sup>2</sup> • PERIMETER: 8.90 m

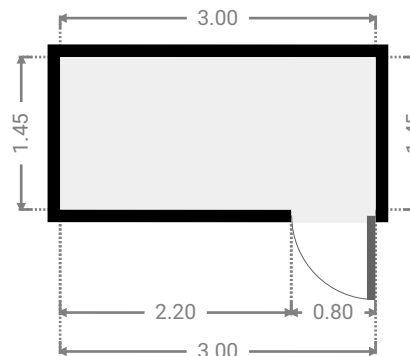
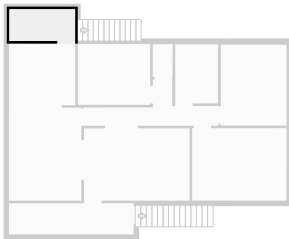

FLOORS: 2

▼ Kitchen  
1st Floor

WIDTH: 3.02 m • LENGTH: 2.82 m  
AREA: 8.52 m<sup>2</sup> • PERIMETER: 11.68 m

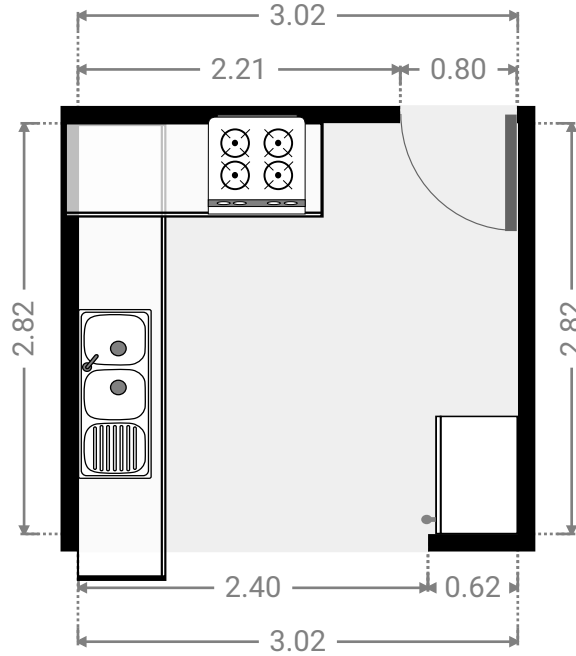

▼ Living Room  
1st Floor

WIDTH: 4.82 m • LENGTH: 3.30 m  
AREA: 15.91 m<sup>2</sup> • PERIMETER: 16.24 m

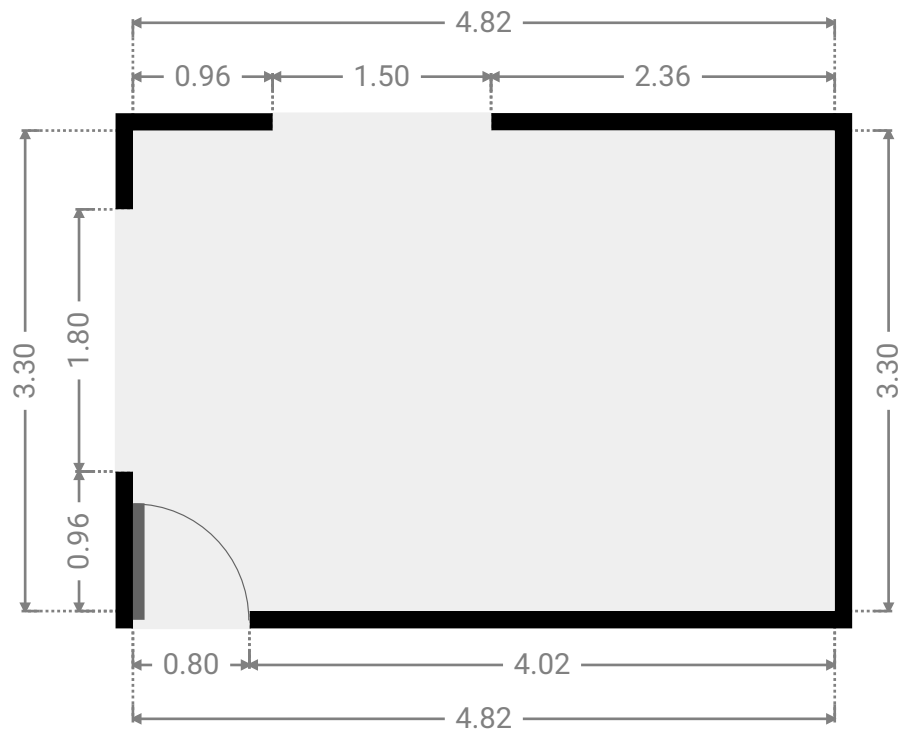

▼ **Other**  
1st Floor

WIDTH: 5.69 m • LENGTH: 1.42 m  
AREA: 8.07 m<sup>2</sup> • PERIMETER: 14.21 m

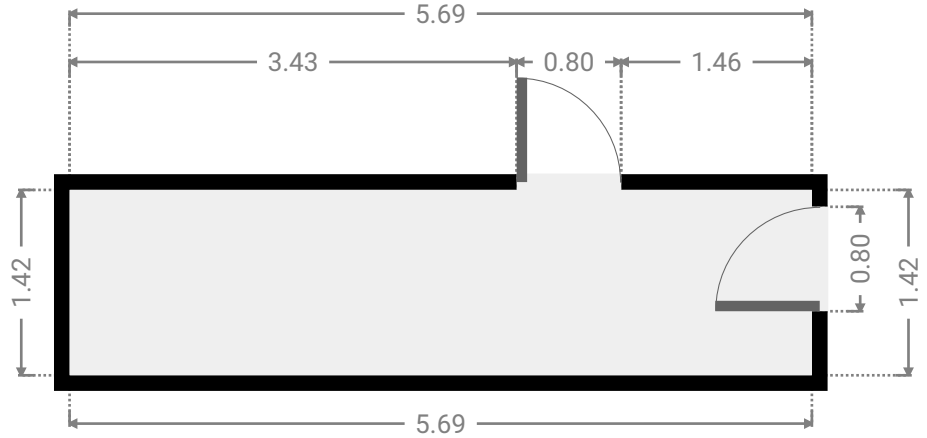
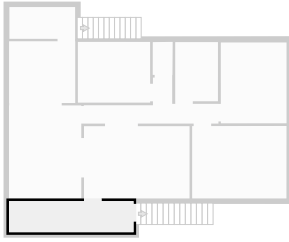

▼ **Primary Bedroom**  
1st Floor

WIDTH: 4.31 m • LENGTH: 3.31 m  
AREA: 14.24 m<sup>2</sup> • PERIMETER: 15.23 m

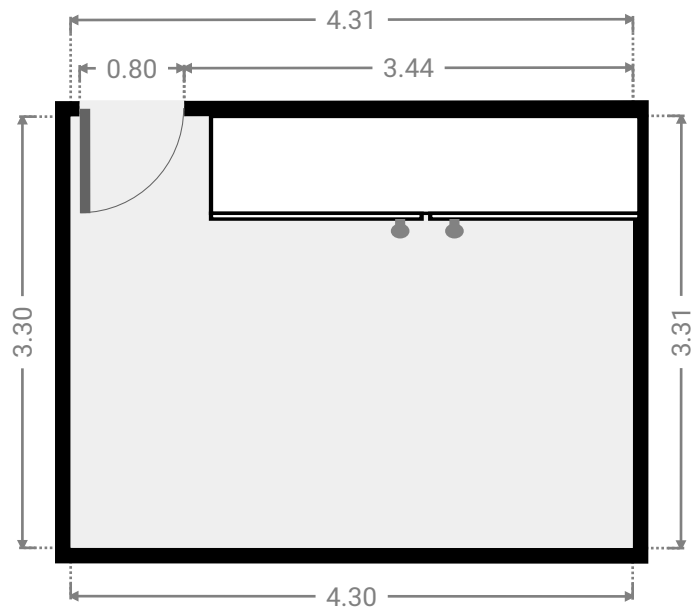
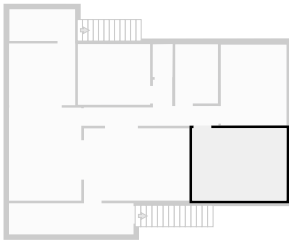

▼ Toilet  
1st Floor

WIDTH: 0.91 m • LENGTH: 1.51 m  
AREA: 1.36 m<sup>2</sup> • PERIMETER: 4.81 m

