

10 Primrose Avenue

Created on
2021-01-13

Floors
1

▼ Ground Floor

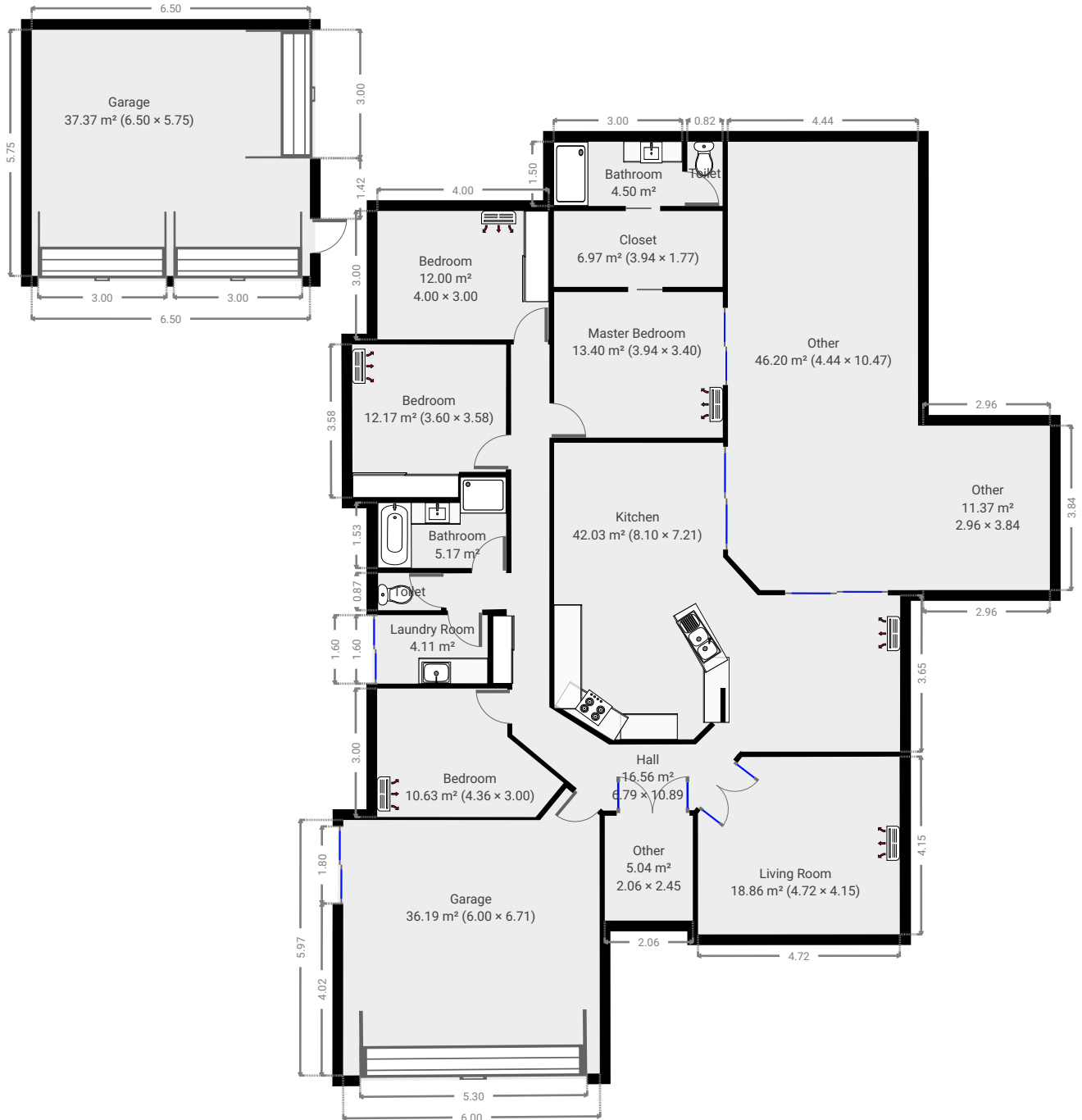

FLOORS:1

▼ **Kitchen**
Ground Floor

WIDTH:8.10 m · LENGTH:7.21 m
AREA:42.03 m² · PERIMETER:29.69 m

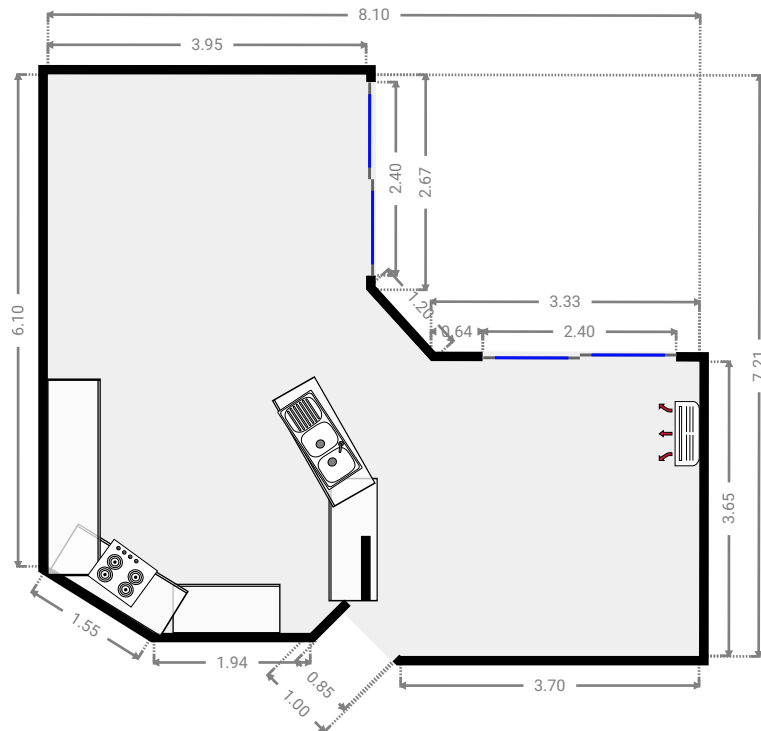
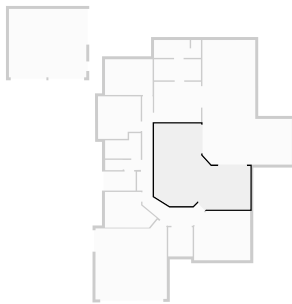

▼ **Other**
Ground Floor

WIDTH:2.06 m · LENGTH:2.45 m
AREA:5.04 m² · PERIMETER:9.02 m

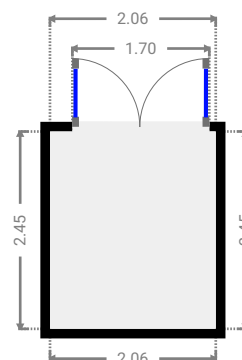
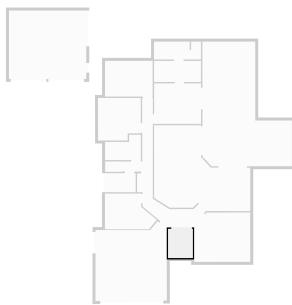

FLOORS:1

▼ **Garage**
Ground Floor

WIDTH:6.50 m · LENGTH:5.75 m
AREA:37.37 m² · PERIMETER:24.50 m

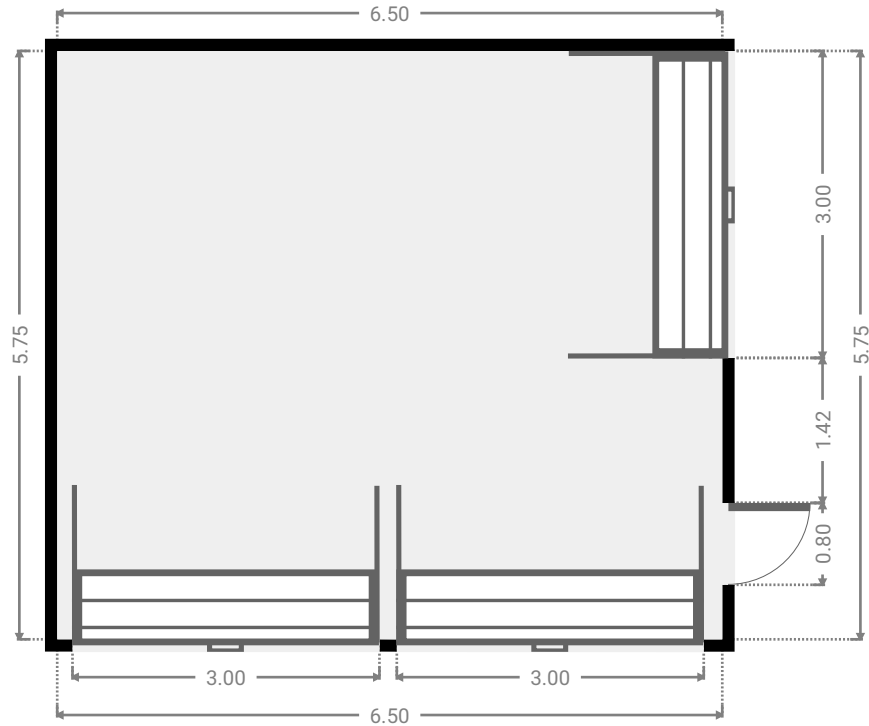
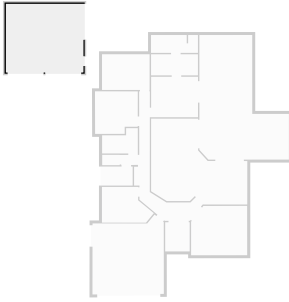

▼ **Other**
Ground Floor

WIDTH:2.96 m · LENGTH:3.84 m
AREA:11.37 m² · PERIMETER:13.60 m

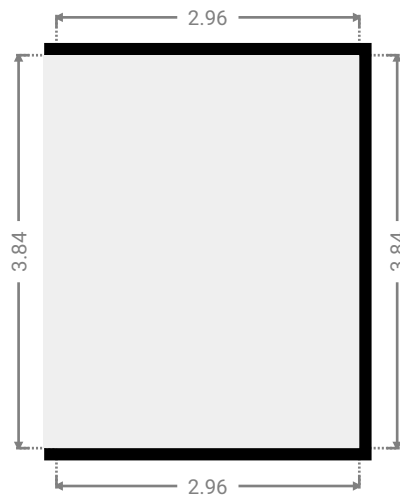

FLOORS:1

▼ **Other**
Ground Floor

WIDTH:4.44 m · LENGTH:10.47 m
AREA:46.20 m² · PERIMETER:29.37 m

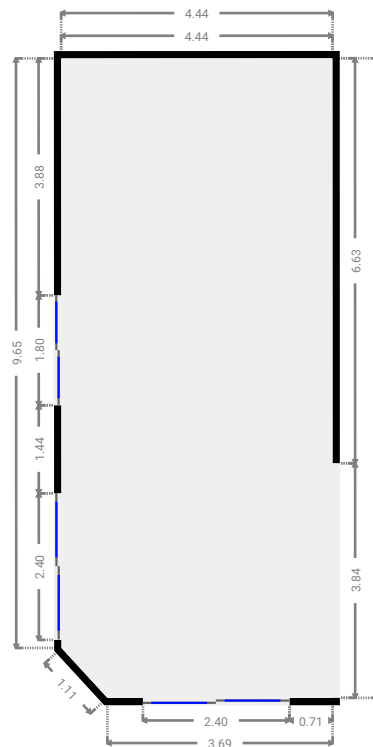
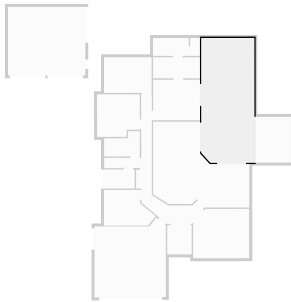

▼ **Toilet**
Ground Floor

WIDTH:0.82 m · LENGTH:1.50 m
AREA:1.24 m² · PERIMETER:4.65 m

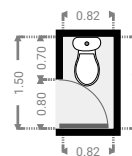
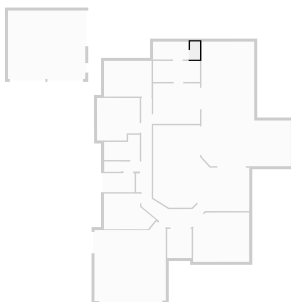

▼ Bathroom
Ground Floor

WIDTH:3.00 m · LENGTH:1.50 m
AREA:4.50 m² · PERIMETER:9.00 m

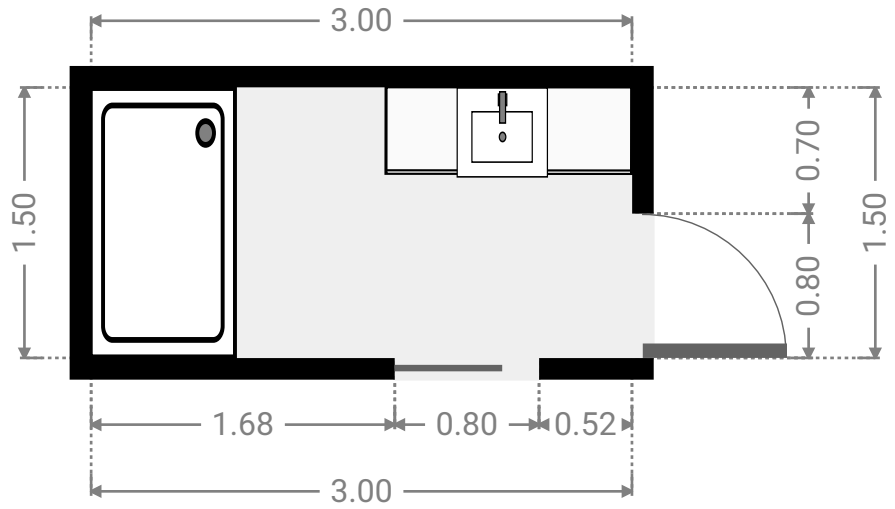
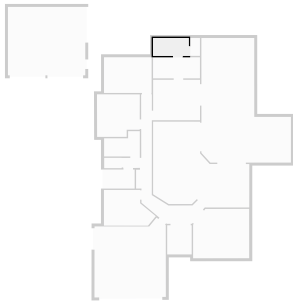

▼ Closet
Ground Floor

WIDTH:3.94 m · LENGTH:1.77 m
AREA:6.97 m² · PERIMETER:11.42 m

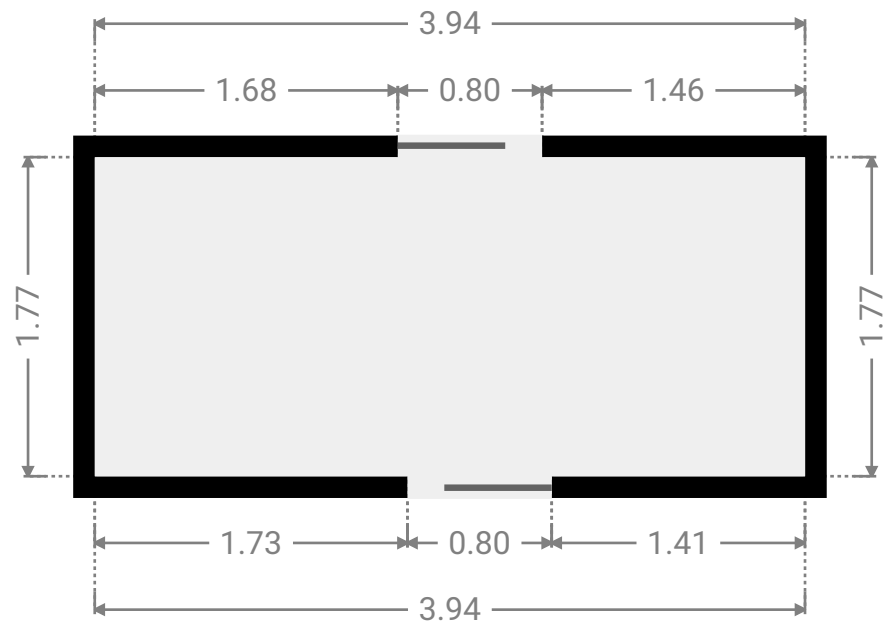
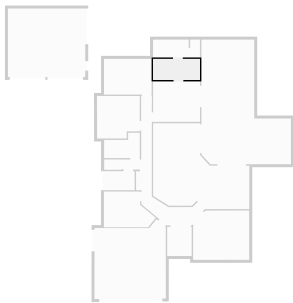

FLOORS:1

▼ Master Bedroom
Ground Floor

WIDTH:3.94 m · LENGTH:3.40 m
AREA:13.40 m² · PERIMETER:14.68 m

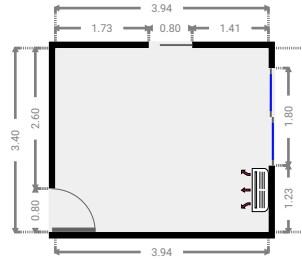
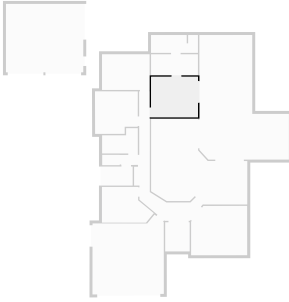

▼ Hall
Ground Floor

WIDTH:6.79 m · LENGTH:10.89 m
AREA:16.56 m² · PERIMETER:33.79 m

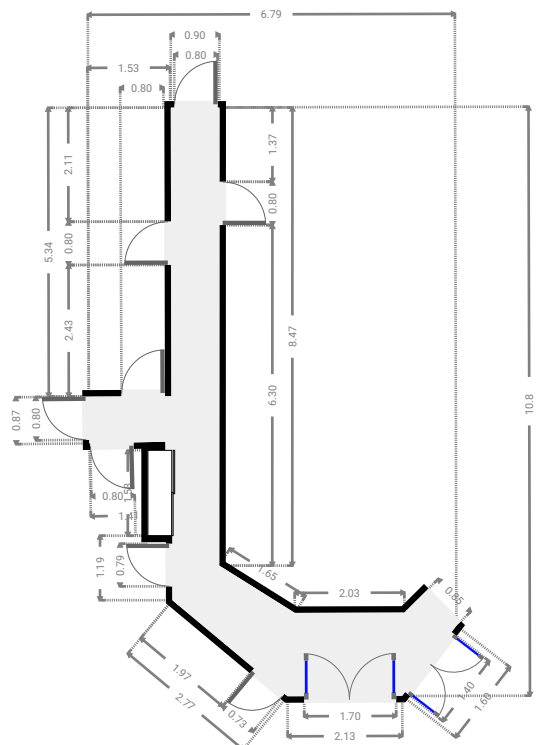
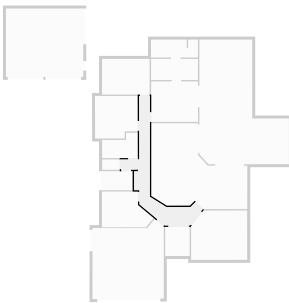

▼ **Bedroom**
Ground Floor

WIDTH:4.00 m · LENGTH:3.00 m
AREA:12.00 m² · PERIMETER:14.00 m

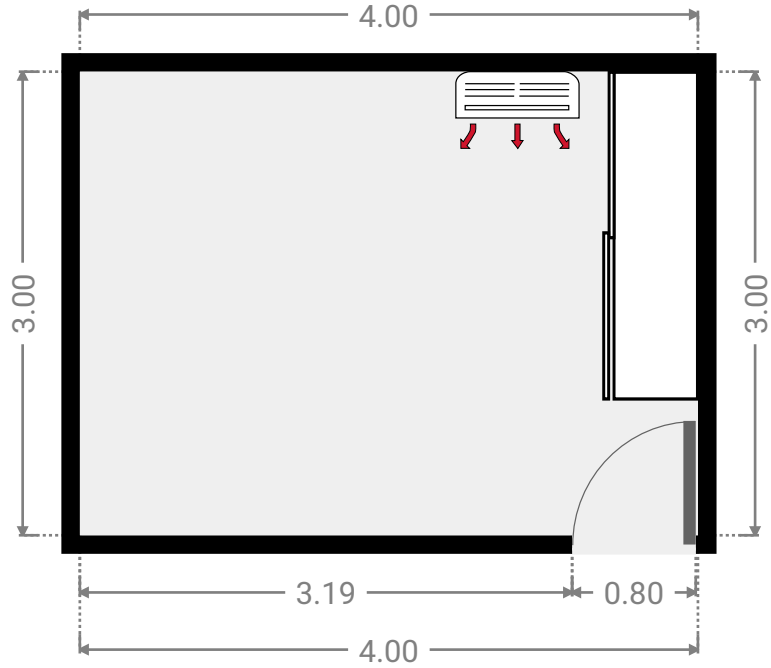
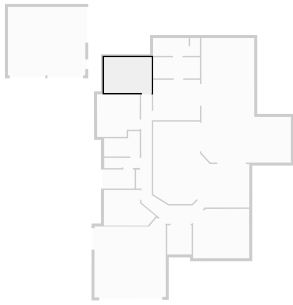

▼ **Bedroom**
Ground Floor

WIDTH:3.60 m · LENGTH:3.58 m
AREA:12.17 m² · PERIMETER:14.33 m

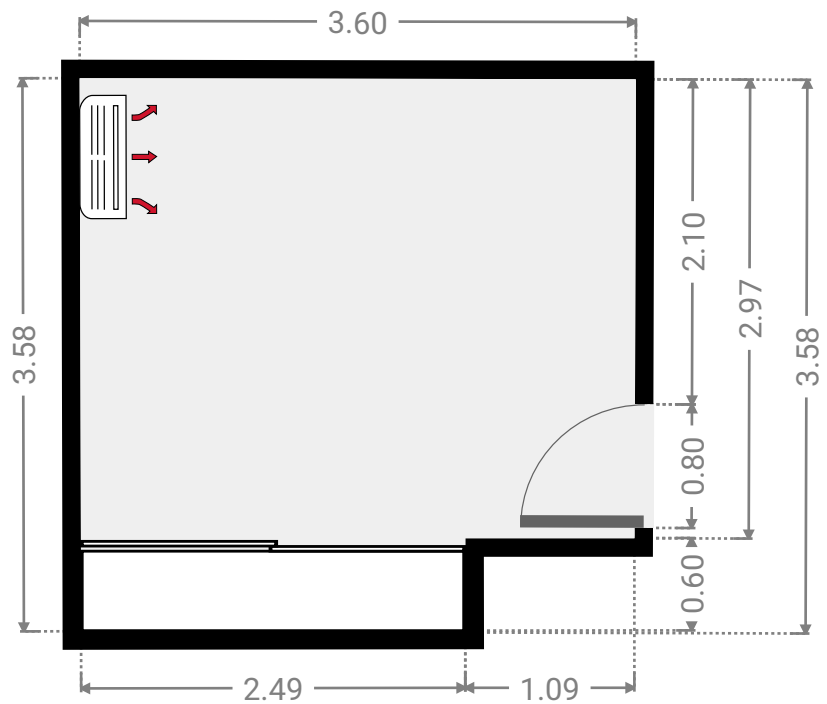
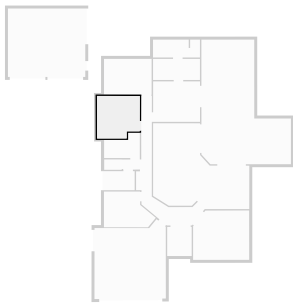

▼ **Bathroom**
Ground Floor

WIDTH:3.00 m · LENGTH:2.13 m
AREA:5.17 m² · PERIMETER:10.25 m

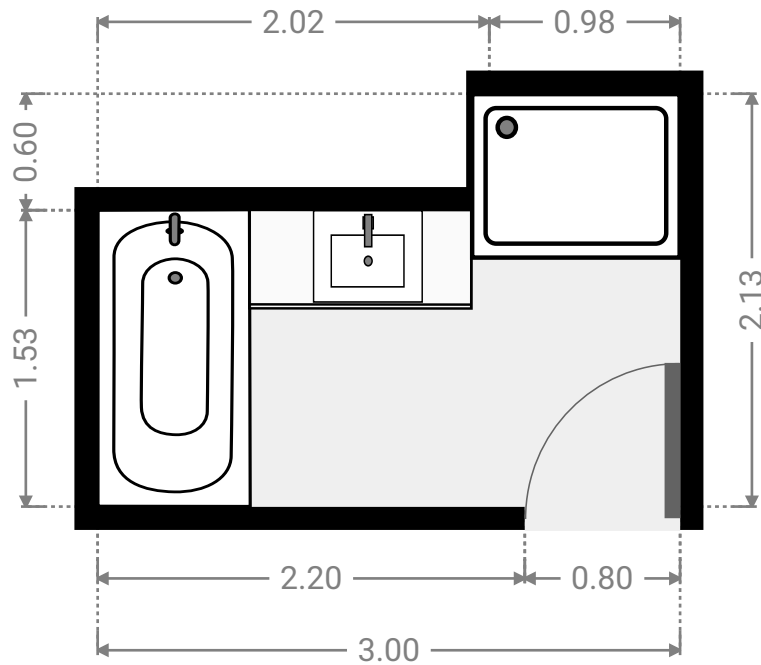
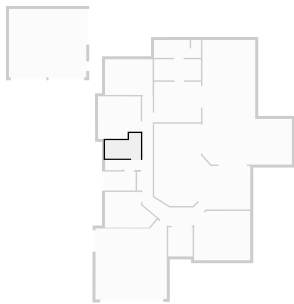

▼ **Toilet**
Ground Floor

WIDTH:1.47 m · LENGTH:0.87 m
AREA:1.28 m² · PERIMETER:4.68 m

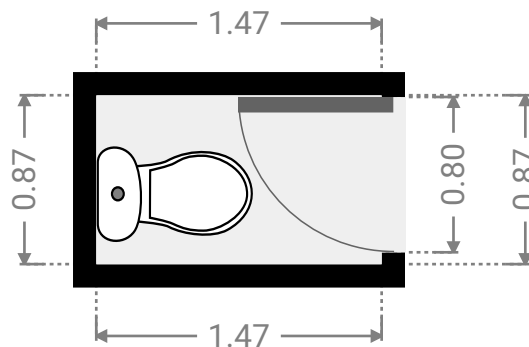
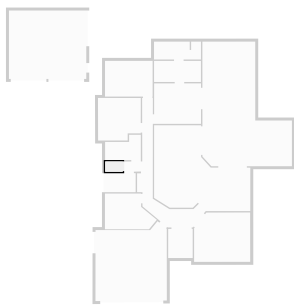

FLOORS:1

▼ Laundry Room
Ground Floor

WIDTH:2.57 m · LENGTH:1.60 m
AREA:4.11 m² · PERIMETER:8.34 m

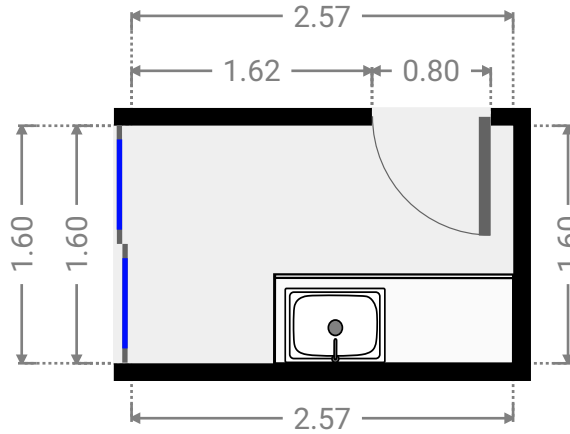

▼ Bedroom
Ground Floor

WIDTH:4.36 m · LENGTH:3.00 m
AREA:10.63 m² · PERIMETER:13.60 m

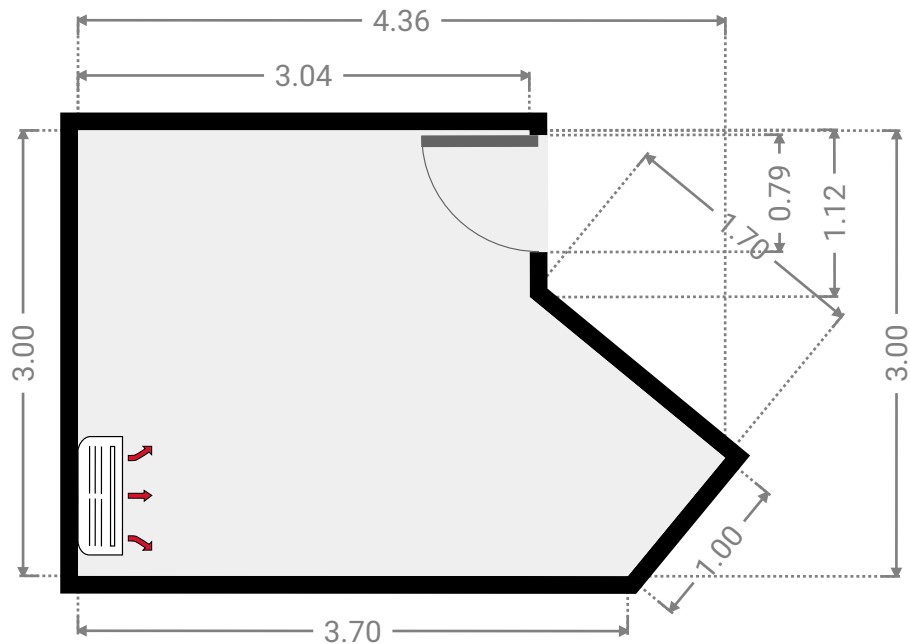
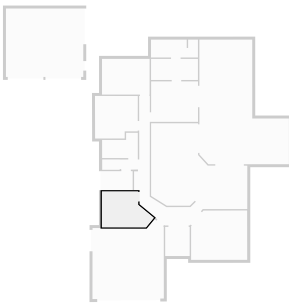

FLOORS:1

▼ **Garage**
Ground Floor

WIDTH:6.00 m · LENGTH:6.71 m
AREA:36.19 m² · PERIMETER:24.57 m

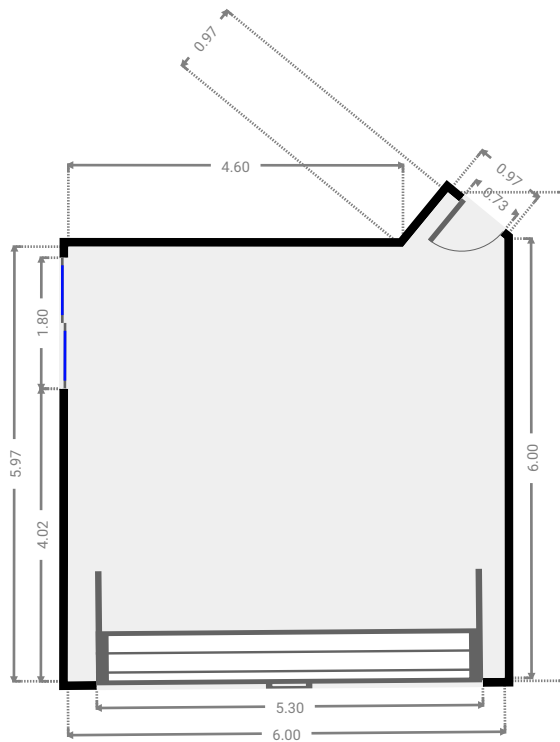
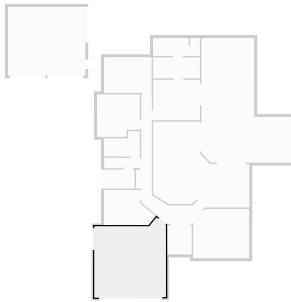

▼ **Living Room**
Ground Floor

WIDTH:4.72 m · LENGTH:4.15 m
AREA:18.86 m² · PERIMETER:17.04 m

