

10 Cant Street

SUBMITTED BY

Ray White Rockhampton Casey
stockers@cqoz.com

CREATED ON

2021-11-16

Floors

2

▼ Ground Floor

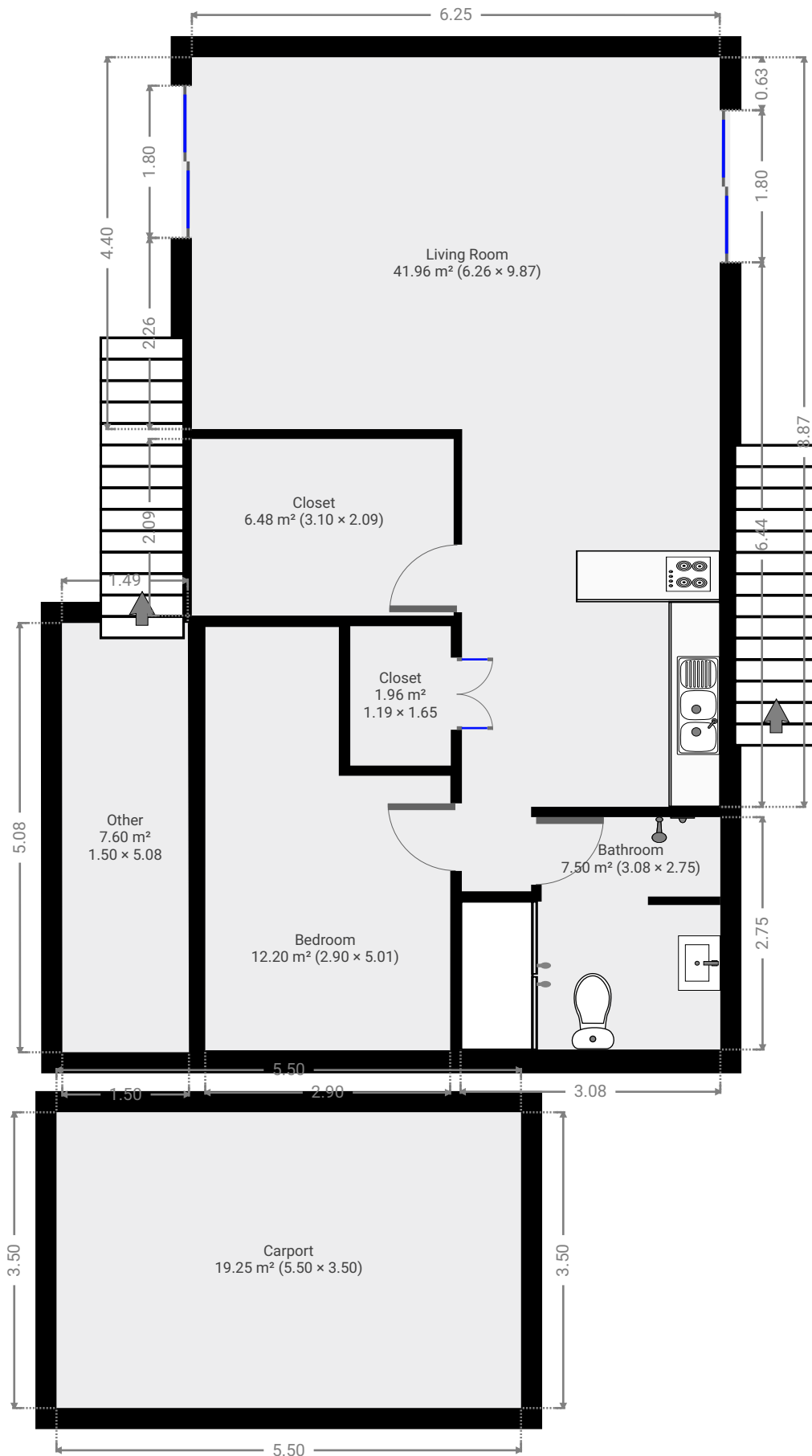

▼ Living Room
Ground Floor

WIDTH: 9.87 m • LENGTH: 6.26 m
AREA: 41.96 m² • PERIMETER: 32.24 m

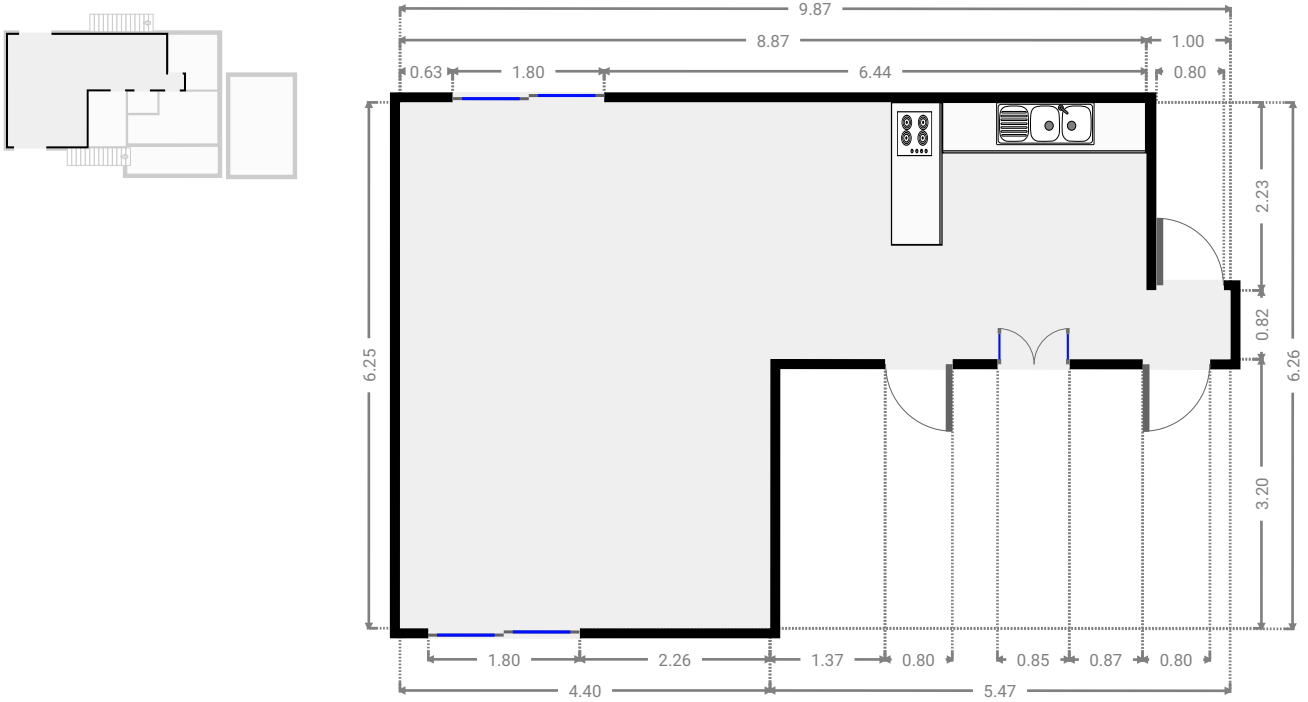

▼ Closet
Ground Floor

WIDTH: 2.09 m • LENGTH: 3.10 m
AREA: 6.48 m² • PERIMETER: 10.38 m

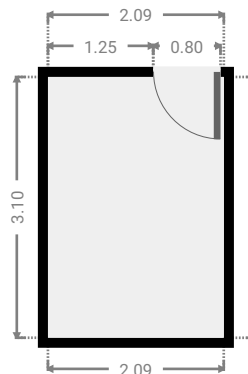
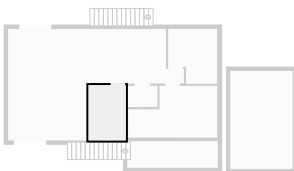

▼ Closet
Ground Floor

WIDTH: 1.65 m • LENGTH: 1.19 m
AREA: 1.96 m² • PERIMETER: 5.68 m

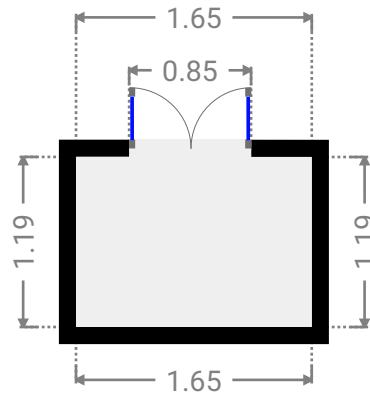
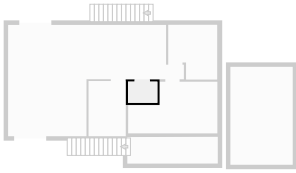

▼ Bedroom
Ground Floor

WIDTH: 5.01 m • LENGTH: 2.91 m
AREA: 12.20 m² • PERIMETER: 15.82 m

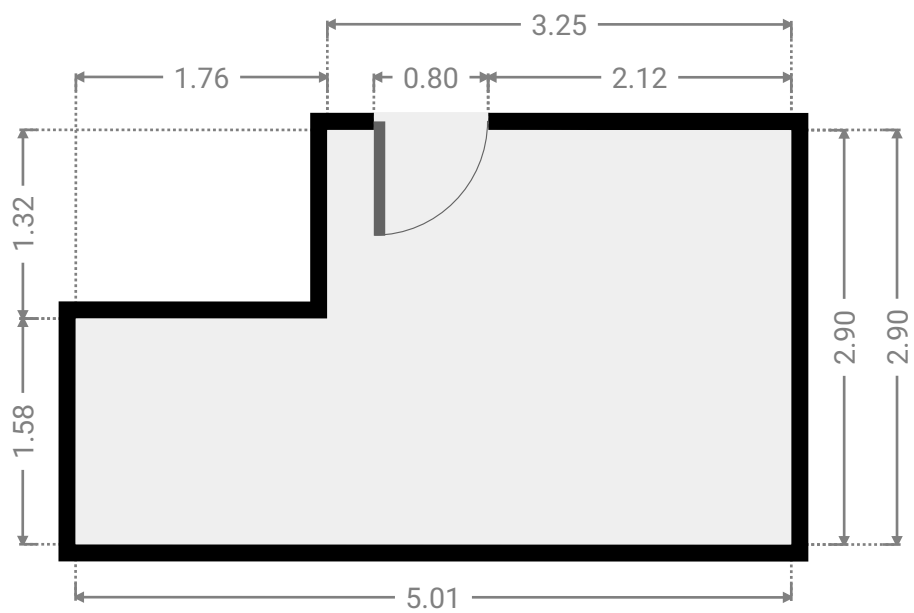
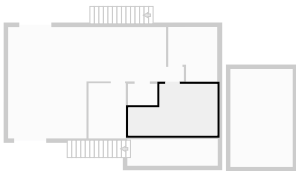

▼ **Bathroom**
Ground Floor

WIDTH: 2.75 m • LENGTH: 3.10 m
AREA: 7.50 m² • PERIMETER: 11.65 m

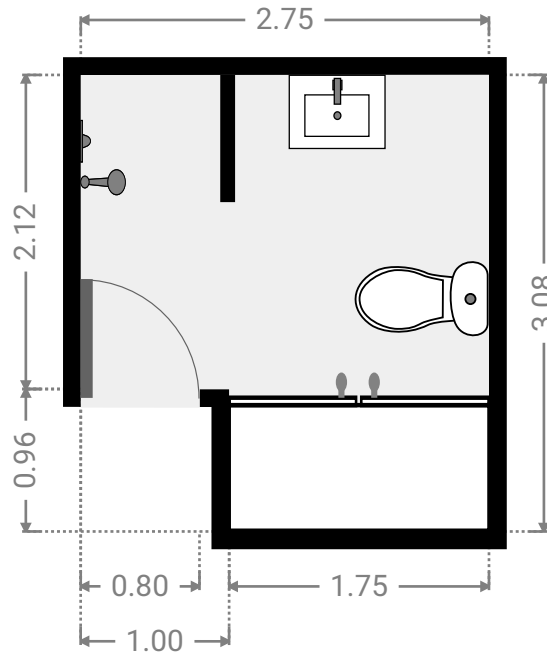
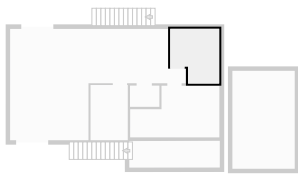

▼ **Other**
Ground Floor

WIDTH: 5.08 m • LENGTH: 1.50 m
AREA: 7.60 m² • PERIMETER: 13.15 m

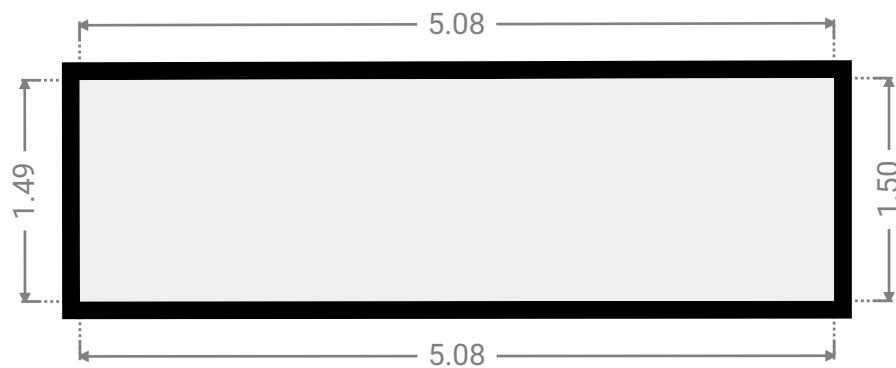
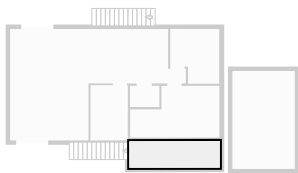

▼ **Carport**
Ground Floor

WIDTH: 3.50 m • LENGTH: 5.50 m
AREA: 19.25 m² • PERIMETER: 18.00 m

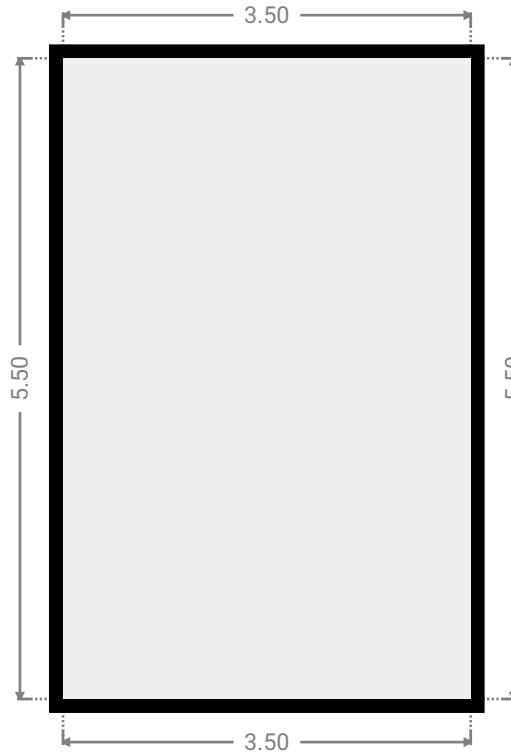
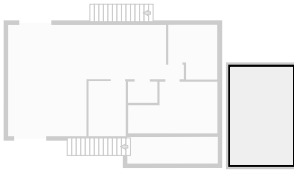

▼ 1st Floor



▼ **Living Room**
1st Floor

WIDTH: 5.09 m • LENGTH: 3.44 m
AREA: 17.51 m² • PERIMETER: 17.06 m

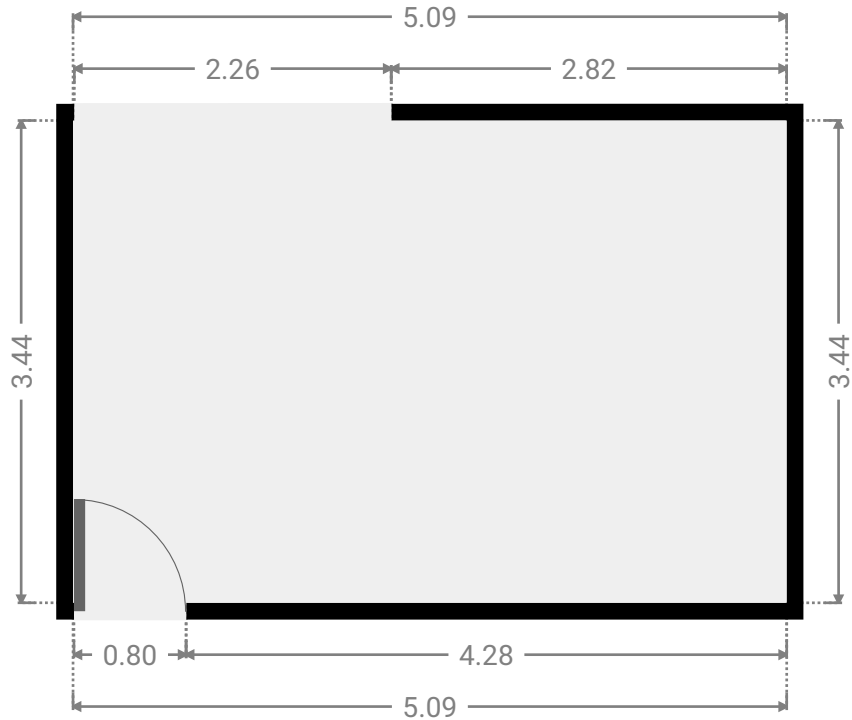
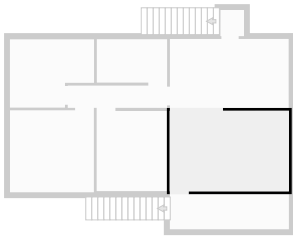

▼ **Kitchen**
1st Floor

WIDTH: 5.07 m • LENGTH: 2.95 m
AREA: 14.95 m² • PERIMETER: 16.04 m

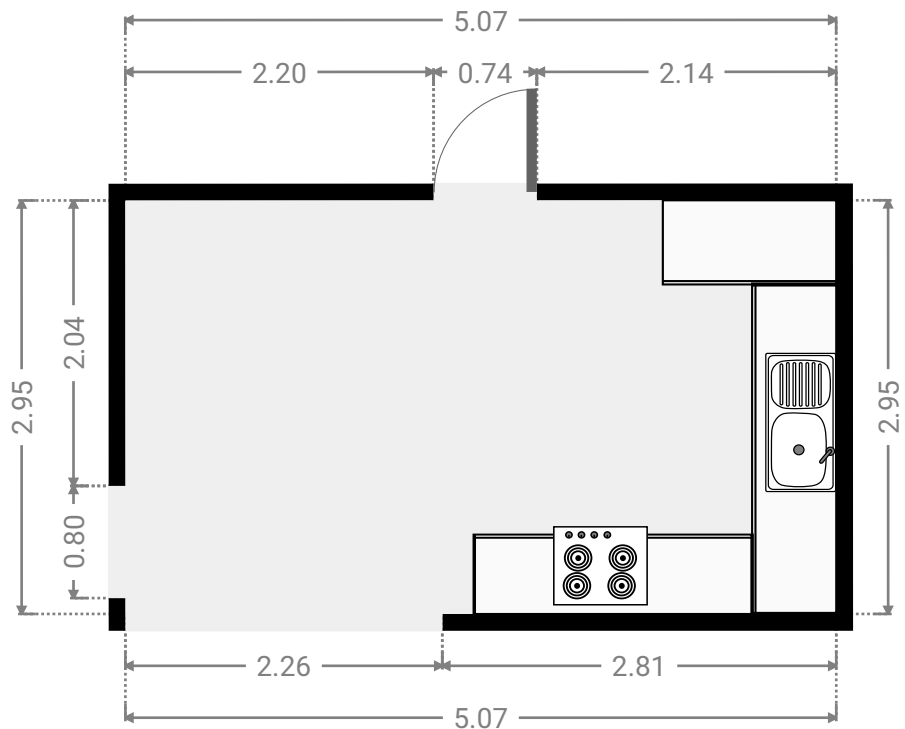
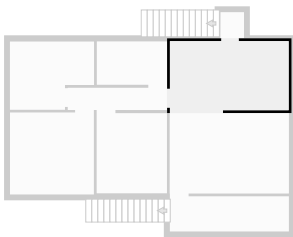

▼ **Hall**
1st Floor

WIDTH: 4.24 m • LENGTH: 0.95 m
AREA: 4.03 m² • PERIMETER: 10.38 m

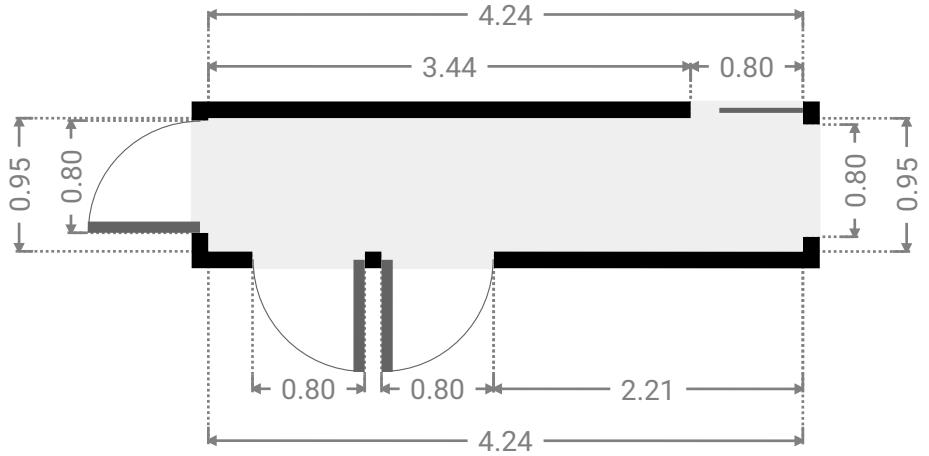
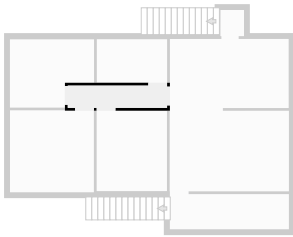

▼ **Bathroom**
1st Floor

WIDTH: 3.00 m • LENGTH: 1.85 m
AREA: 5.55 m² • PERIMETER: 9.70 m

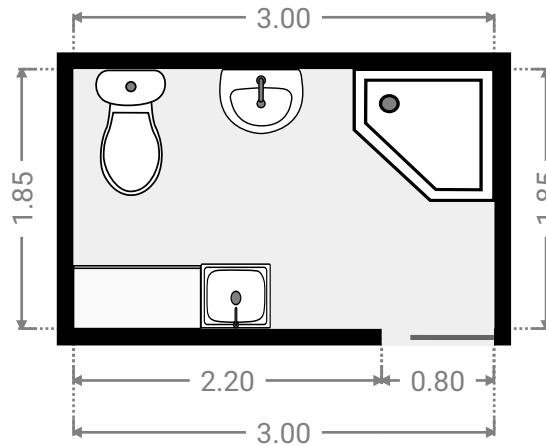
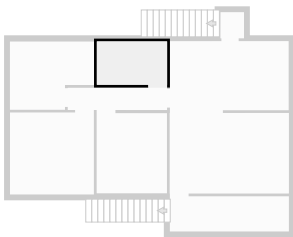

▼ **Bedroom**
1st Floor

WIDTH: 3.00 m • LENGTH: 3.42 m
AREA: 10.26 m² • PERIMETER: 12.84 m

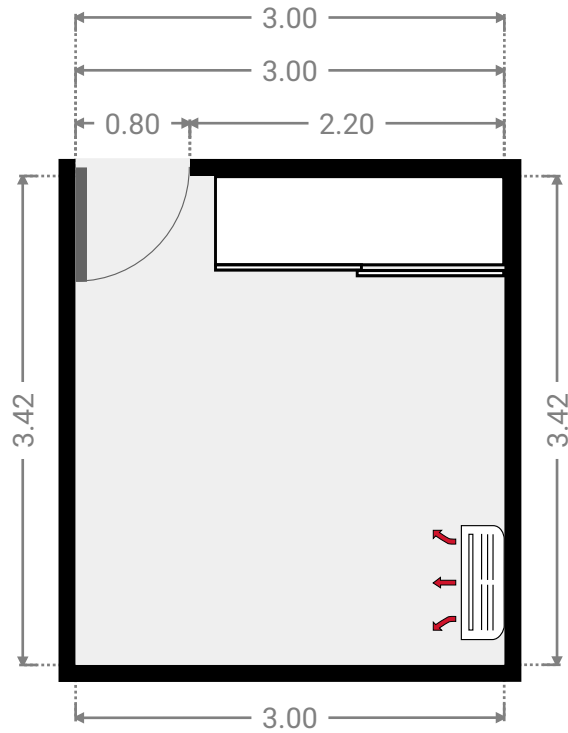
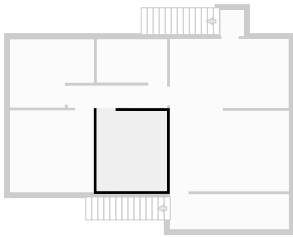

▼ **Bedroom**
1st Floor

WIDTH: 3.58 m • LENGTH: 3.50 m
AREA: 12.53 m² • PERIMETER: 14.16 m

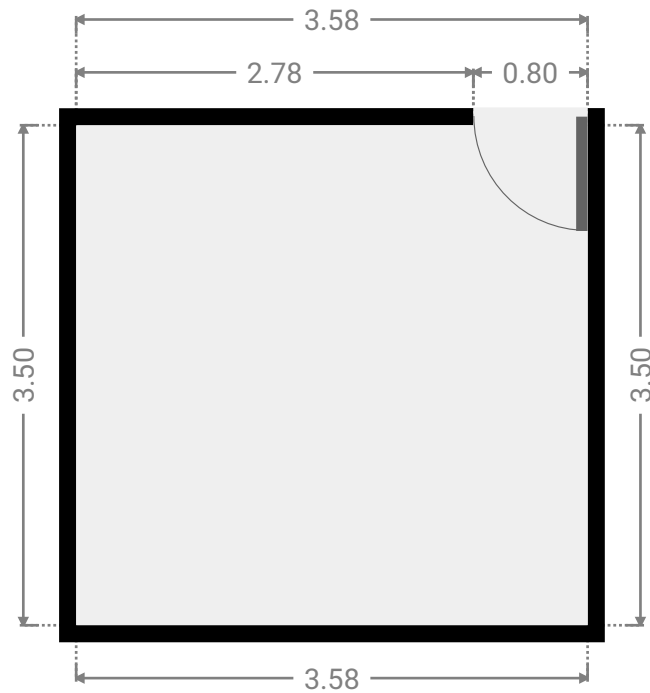
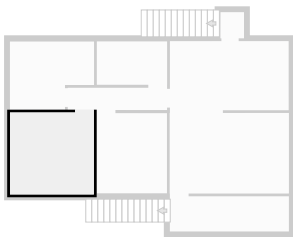

▼ **Bedroom**
1st Floor

WIDTH: 3.59 m • LENGTH: 2.91 m
AREA: 9.15 m² • PERIMETER: 13.01 m

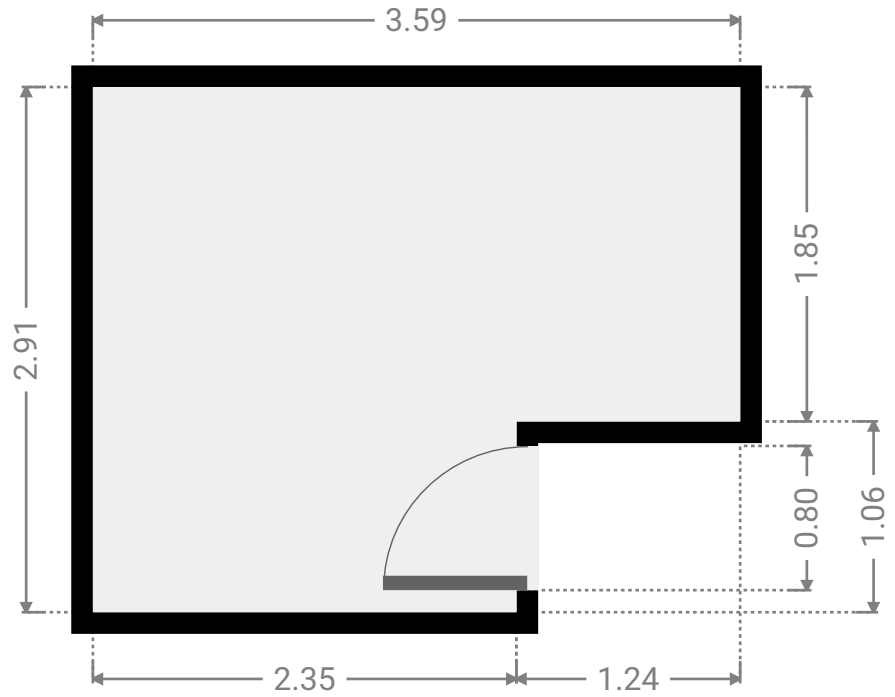
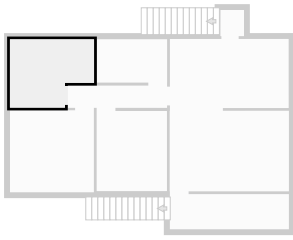

▼ **Hall**
1st Floor

WIDTH: 1.01 m • LENGTH: 1.12 m
AREA: 1.12 m² • PERIMETER: 4.24 m

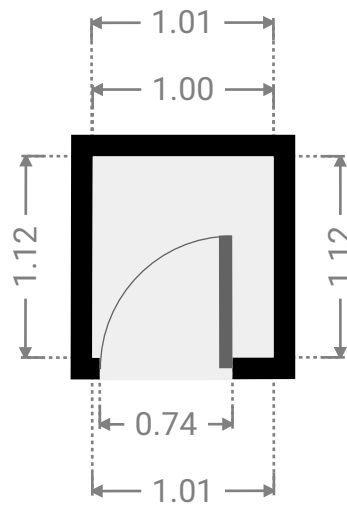
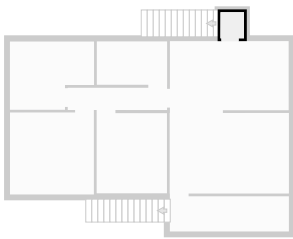

▼ Other
1st Floor

WIDTH: 5.08 m • LENGTH: 1.50 m
AREA: 7.62 m² • PERIMETER: 13.16 m

