

# 10/74 Richmond Street

Created on  
2021-03-04

Floors  
1

▼ Ground Floor

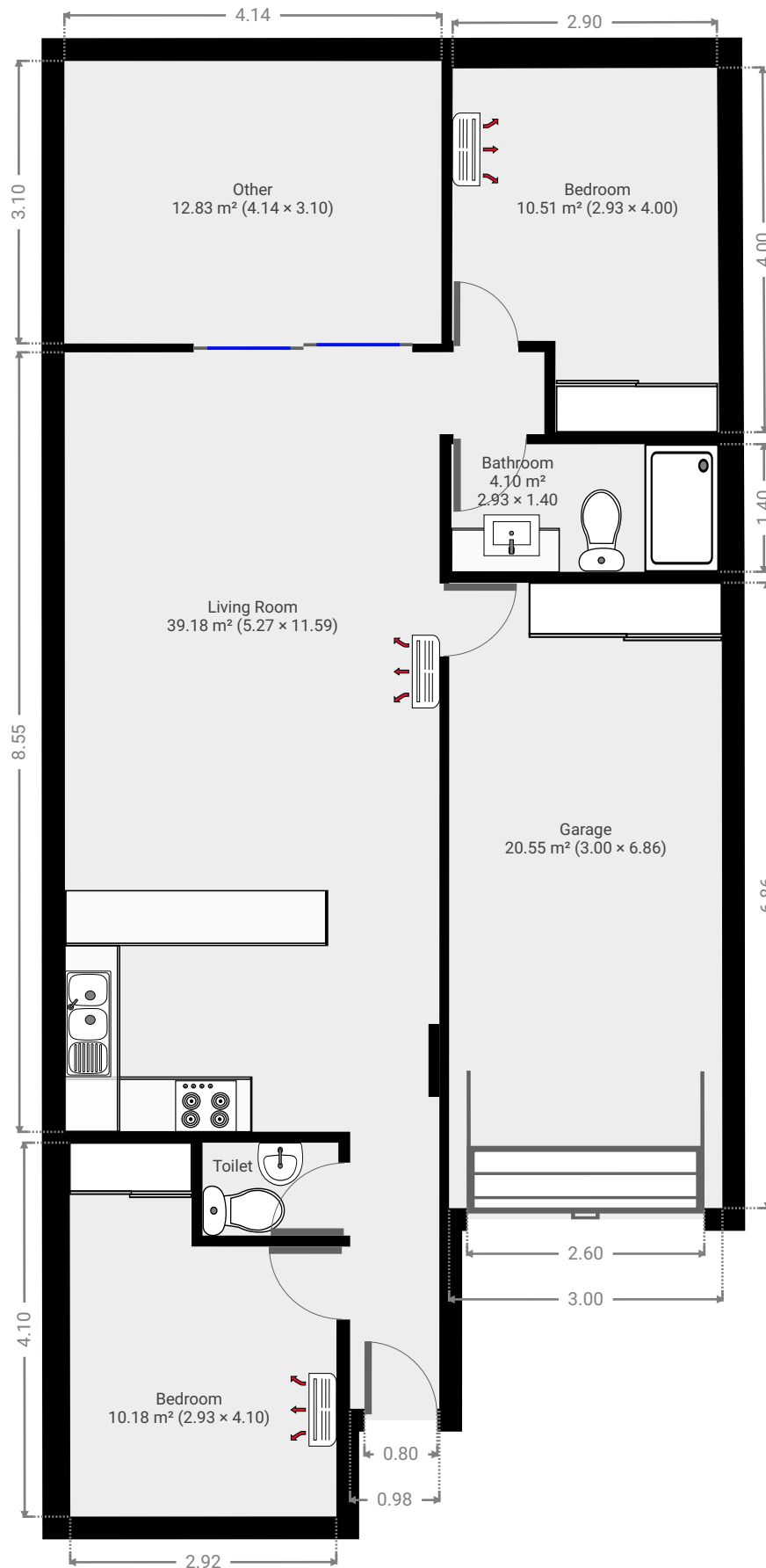

▼ Living Room  
Ground Floor

WIDTH: 5.27 m • LENGTH: 11.59 m  
AREA: 39.18 m<sup>2</sup> • PERIMETER: 33.71 m

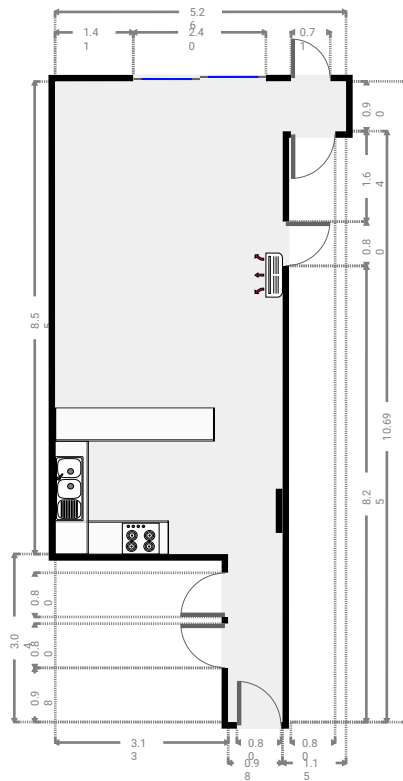
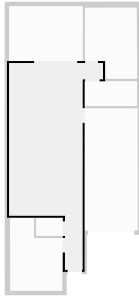

▼ Bedroom  
Ground Floor

WIDTH: 2.93 m • LENGTH: 4.10 m  
AREA: 10.18 m<sup>2</sup> • PERIMETER: 14.05 m

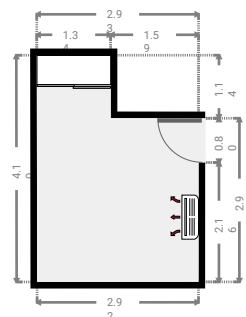
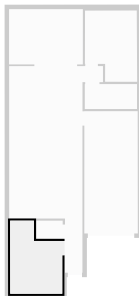

▼ Toilet  
Ground Floor

WIDTH: 1.49 m • LENGTH: 1.02 m  
AREA: 1.52 m<sup>2</sup> • PERIMETER: 5.02 m

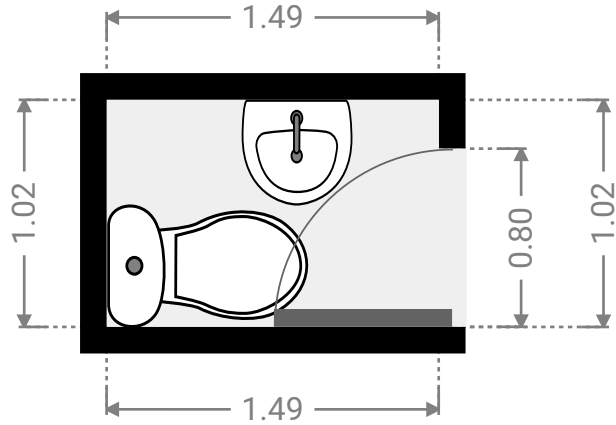
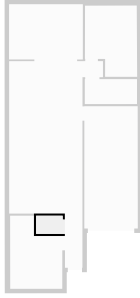

▼ Bathroom  
Ground Floor

WIDTH: 2.93 m • LENGTH: 1.40 m  
AREA: 4.10 m<sup>2</sup> • PERIMETER: 8.66 m

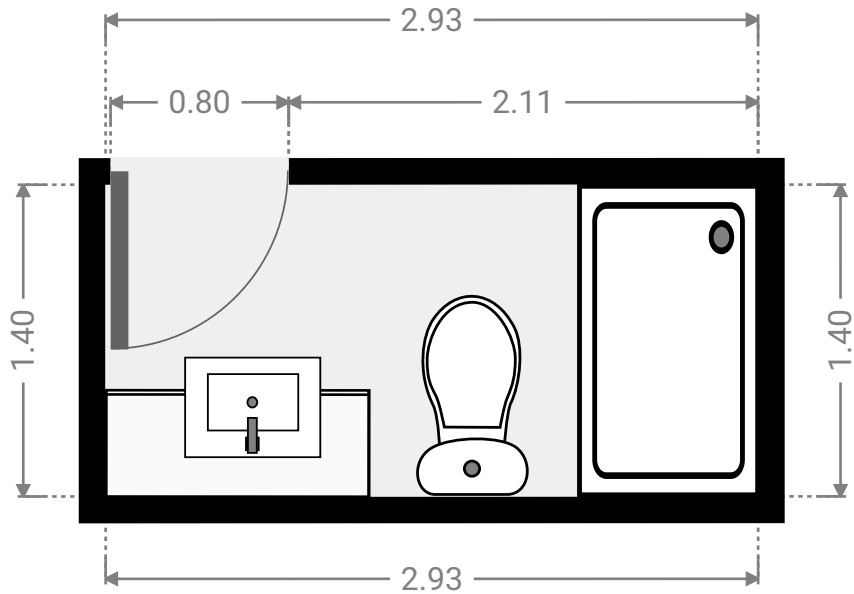
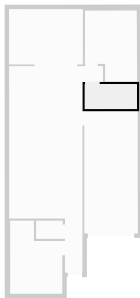

▼ **Bedroom**  
Ground Floor

WIDTH: 2.93 m • LENGTH: 4.00 m  
AREA: 10.51 m<sup>2</sup> • PERIMETER: 13.82 m

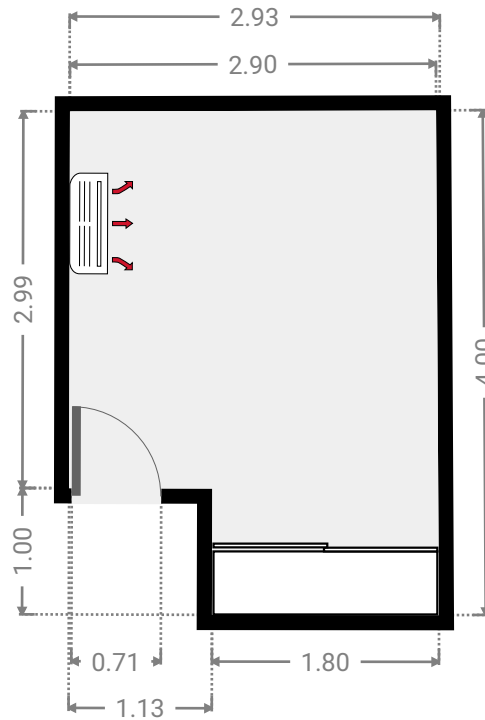
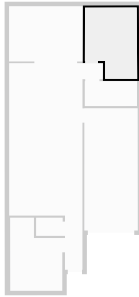

▼ **Other**  
Ground Floor

WIDTH: 4.14 m • LENGTH: 3.10 m  
AREA: 12.83 m<sup>2</sup> • PERIMETER: 14.48 m

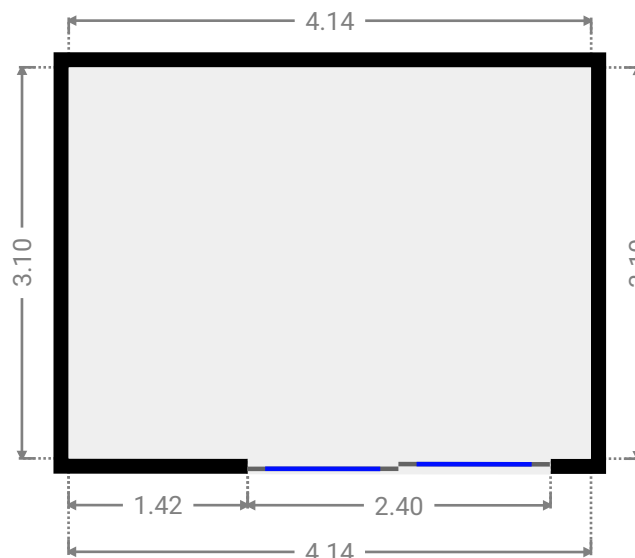
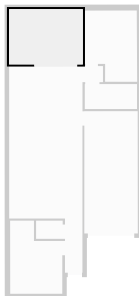

▼ **Garage**  
Ground Floor

WIDTH: 3.00 m • LENGTH: 6.86 m  
AREA: 20.55 m<sup>2</sup> • PERIMETER: 19.71 m

