

1/6 Dalton Avenue

Created on
2021-06-22

Floors
1

▼ Ground Floor

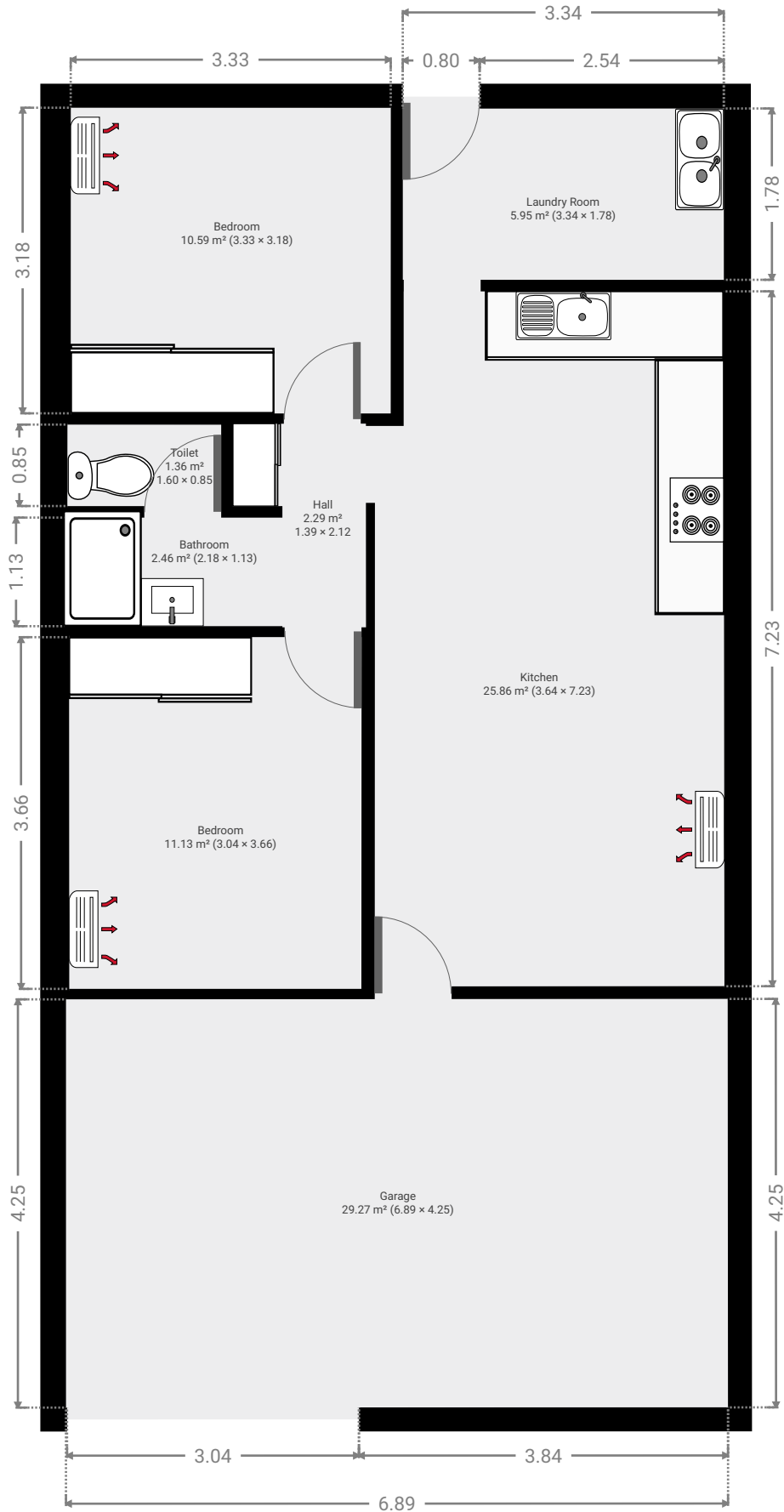

▼ Kitchen
Ground Floor

WIDTH: 3.64 m • LENGTH: 7.23 m
AREA: 25.86 m² • PERIMETER: 21.73 m

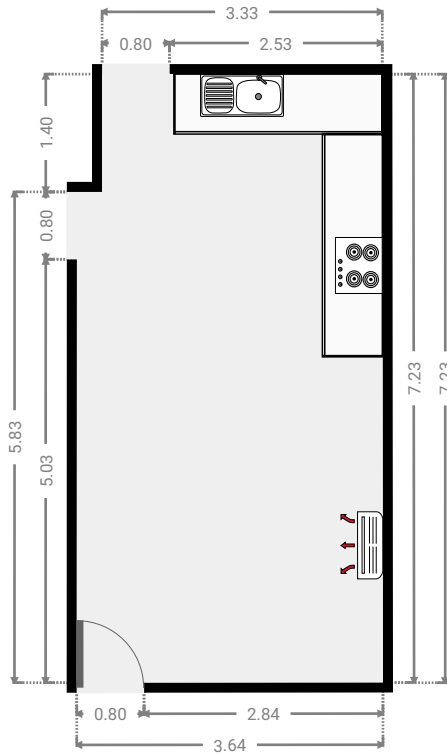
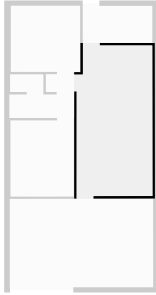

▼ Hall
Ground Floor

WIDTH: 1.39 m • LENGTH: 2.12 m
AREA: 2.29 m² • PERIMETER: 7.02 m

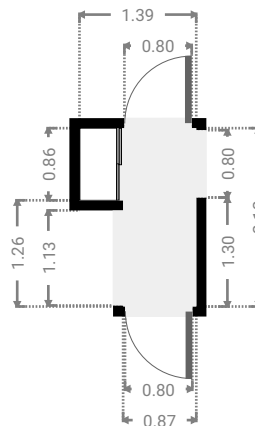
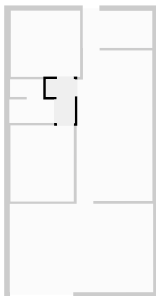

▼ **Bedroom**
Ground Floor

WIDTH: 3.33 m • LENGTH: 3.18 m
AREA: 10.59 m² • PERIMETER: 13.02 m

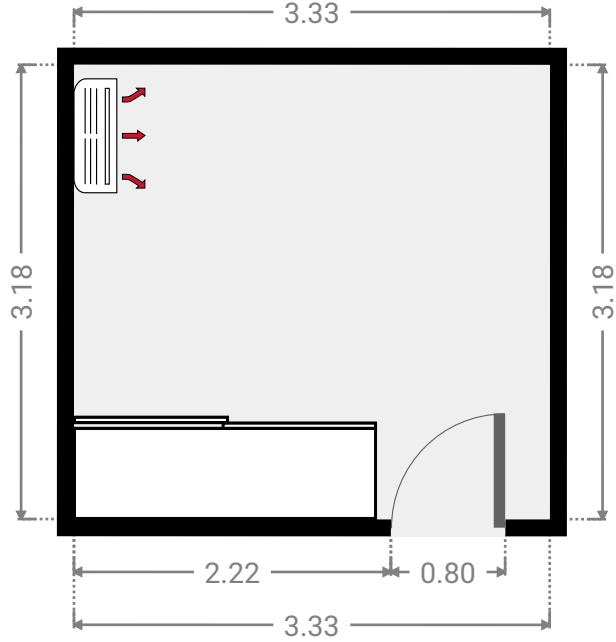
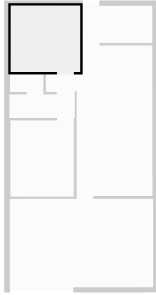

▼ **Bedroom**
Ground Floor

WIDTH: 3.04 m • LENGTH: 3.66 m
AREA: 11.13 m² • PERIMETER: 13.40 m

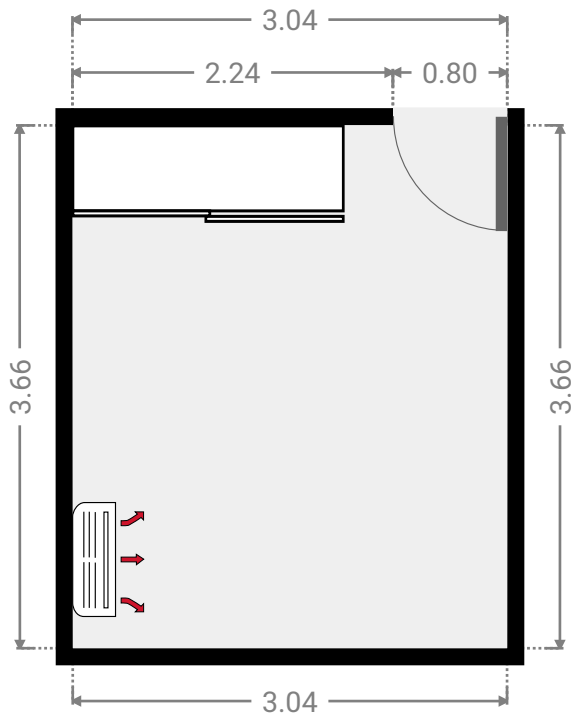
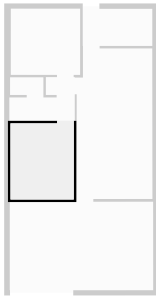

▼ Bathroom
Ground Floor

WIDTH: 2.18 m • LENGTH: 1.13 m
AREA: 2.46 m² • PERIMETER: 6.62 m

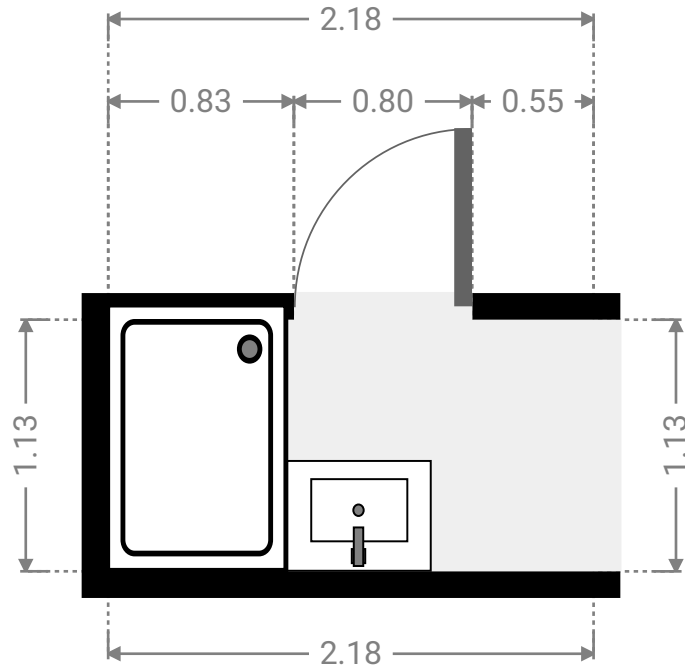
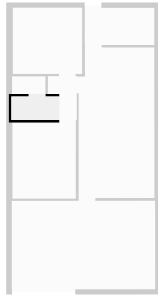

▼ Toilet
Ground Floor

WIDTH: 1.60 m • LENGTH: 0.85 m
AREA: 1.36 m² • PERIMETER: 4.89 m

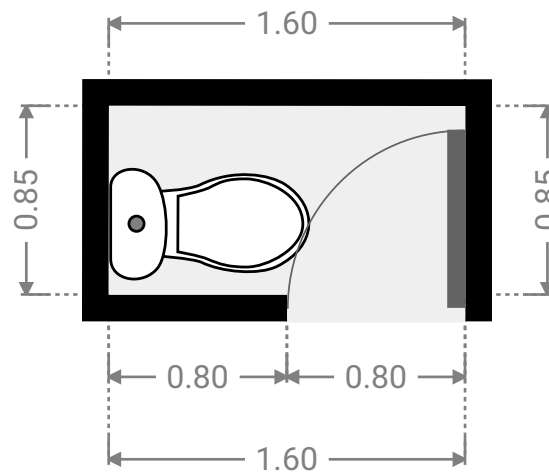
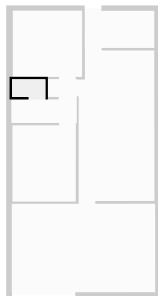

▼ Laundry Room
Ground Floor

WIDTH: 3.34 m • LENGTH: 1.78 m
AREA: 5.95 m² • PERIMETER: 10.25 m

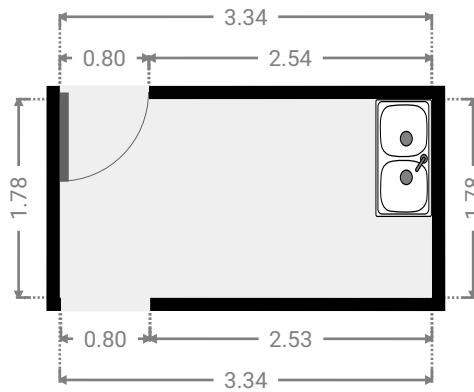
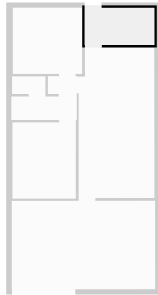

▼ Garage
Ground Floor

WIDTH: 6.89 m • LENGTH: 4.25 m
AREA: 29.27 m² • PERIMETER: 22.27 m

