

1/6 Thurston Street

SUBMITTED BY

Ray White Rockhampton Casey
stockers@cqoz.com

CREATED ON

2022-10-17

Floors

1

▼ Ground Floor

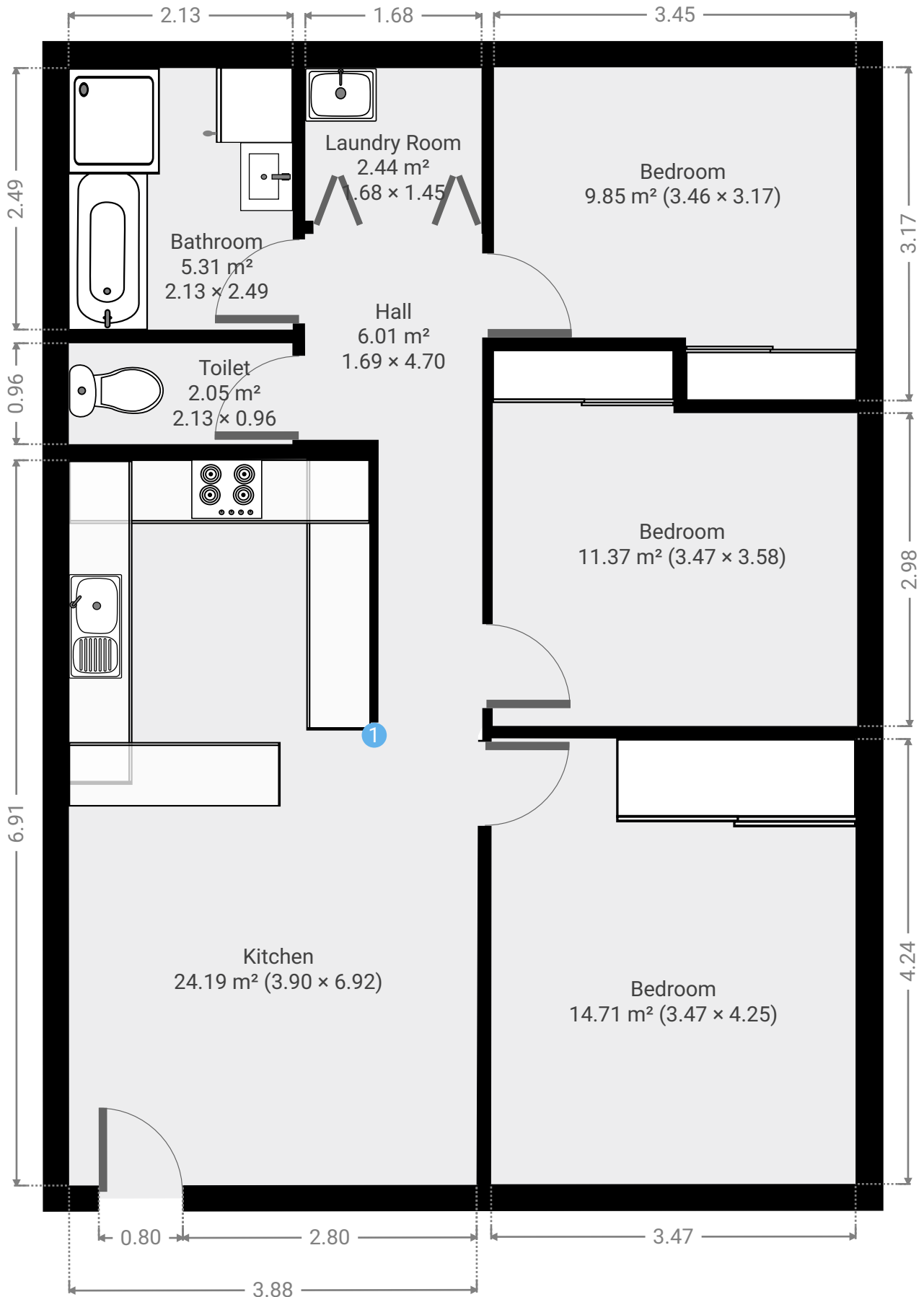

FLOORS: 1

▼ **Bathroom**
Ground Floor

WIDTH: 2.13 m • LENGTH: 2.49 m
AREA: 5.31 m² • PERIMETER: 9.25 m

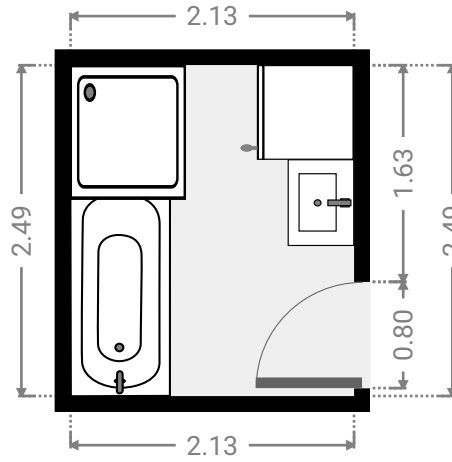
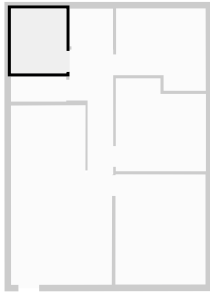

▼ **Bedroom**
Ground Floor

WIDTH: 3.47 m • LENGTH: 4.25 m
AREA: 14.71 m² • PERIMETER: 15.42 m

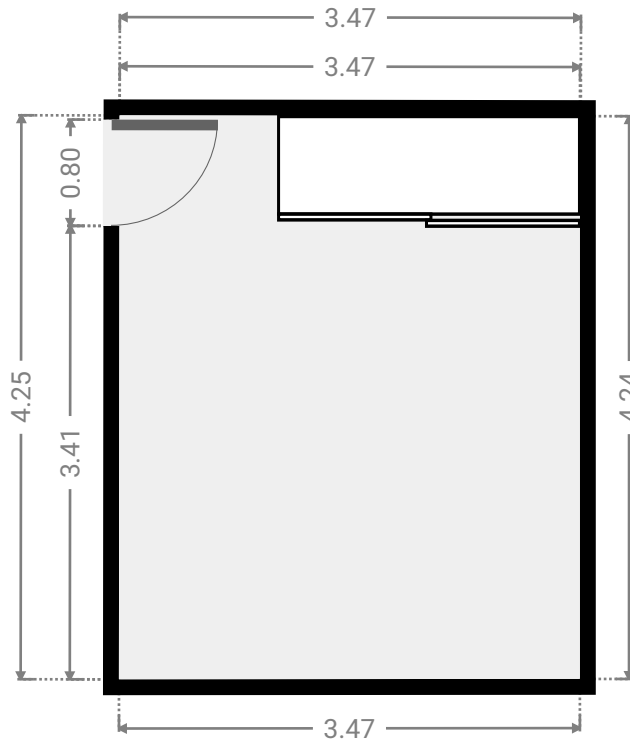
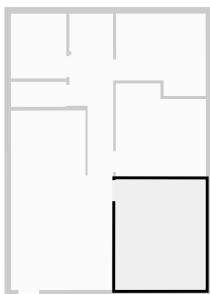

FLOORS: 1

▼ **Bedroom**
Ground Floor

WIDTH: 3.47 m • LENGTH: 3.58 m
AREA: 11.37 m² • PERIMETER: 14.10 m

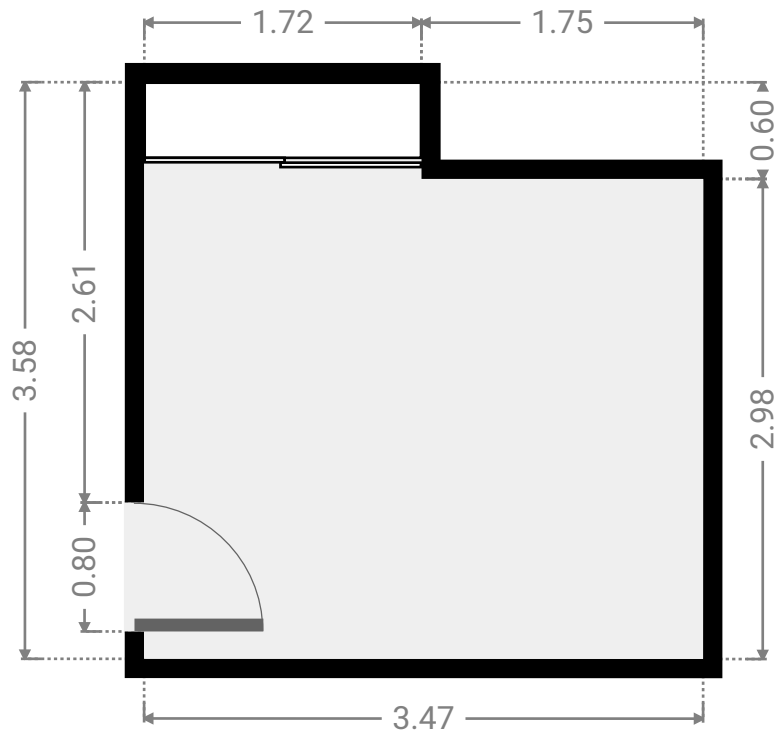
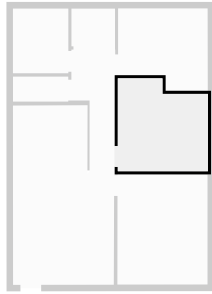

▼ **Bedroom**
Ground Floor

WIDTH: 3.46 m • LENGTH: 3.17 m
AREA: 9.85 m² • PERIMETER: 13.25 m

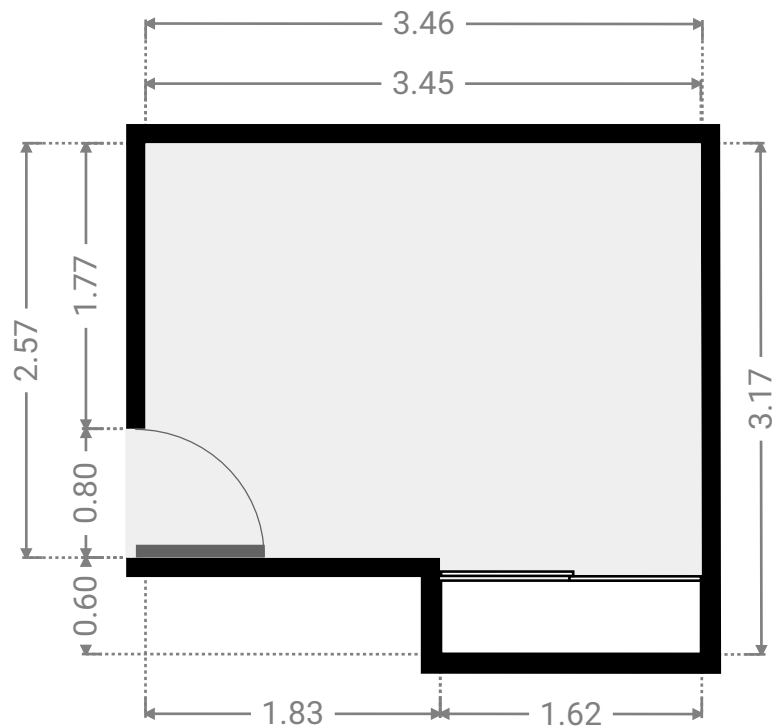
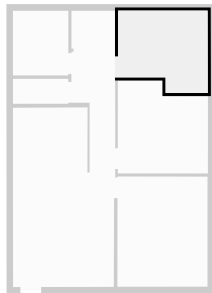

▼ **Hall**
Ground Floor

WIDTH: 1.69 m • LENGTH: 4.70 m
AREA: 6.01 m² • PERIMETER: 12.77 m

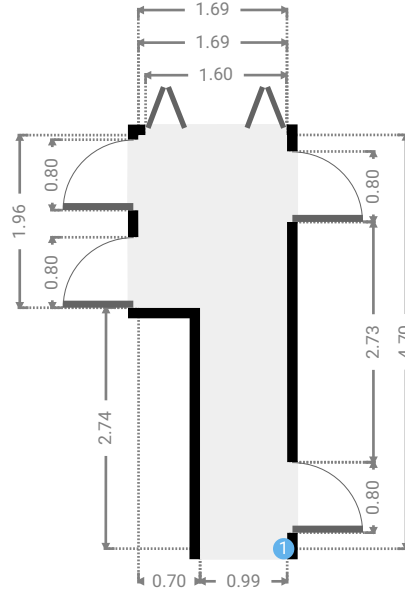
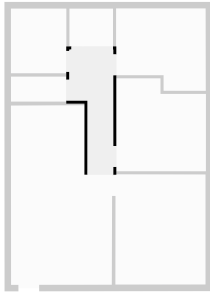

▼ **Kitchen**
Ground Floor

WIDTH: 3.90 m • LENGTH: 6.92 m
AREA: 24.19 m² • PERIMETER: 21.60 m

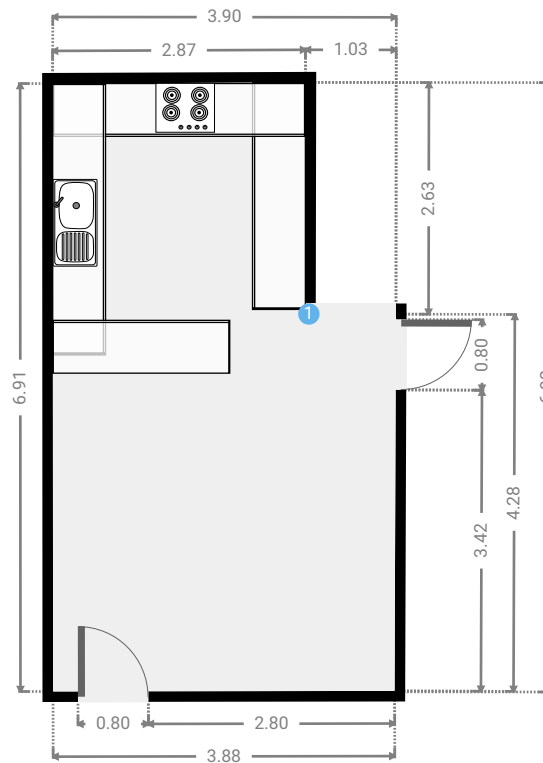
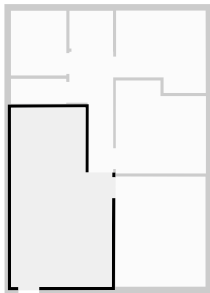

▼ **Kitchen**/Ground Floor

1 **OPENING**

Height
0.00 m



FLOORS: 1

▼ Laundry Room
Ground Floor

WIDTH: 1.68 m • LENGTH: 1.45 m
AREA: 2.44 m² • PERIMETER: 6.26 m

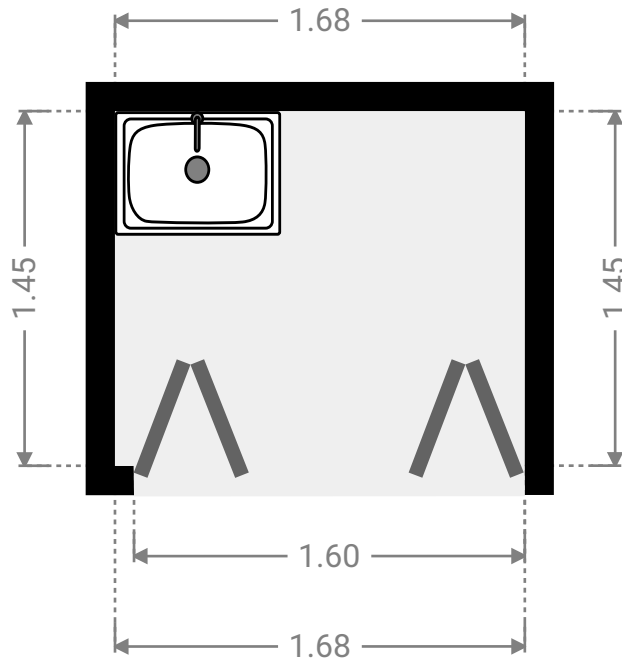
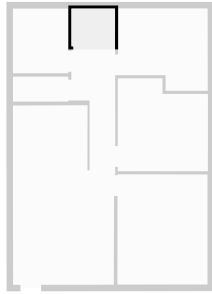

▼ Toilet
Ground Floor

WIDTH: 2.13 m • LENGTH: 0.96 m
AREA: 2.05 m² • PERIMETER: 6.18 m

