

# 1/324 Thozet Road

Created on  
2021-07-22

Floors  
1

▼ Ground Floor

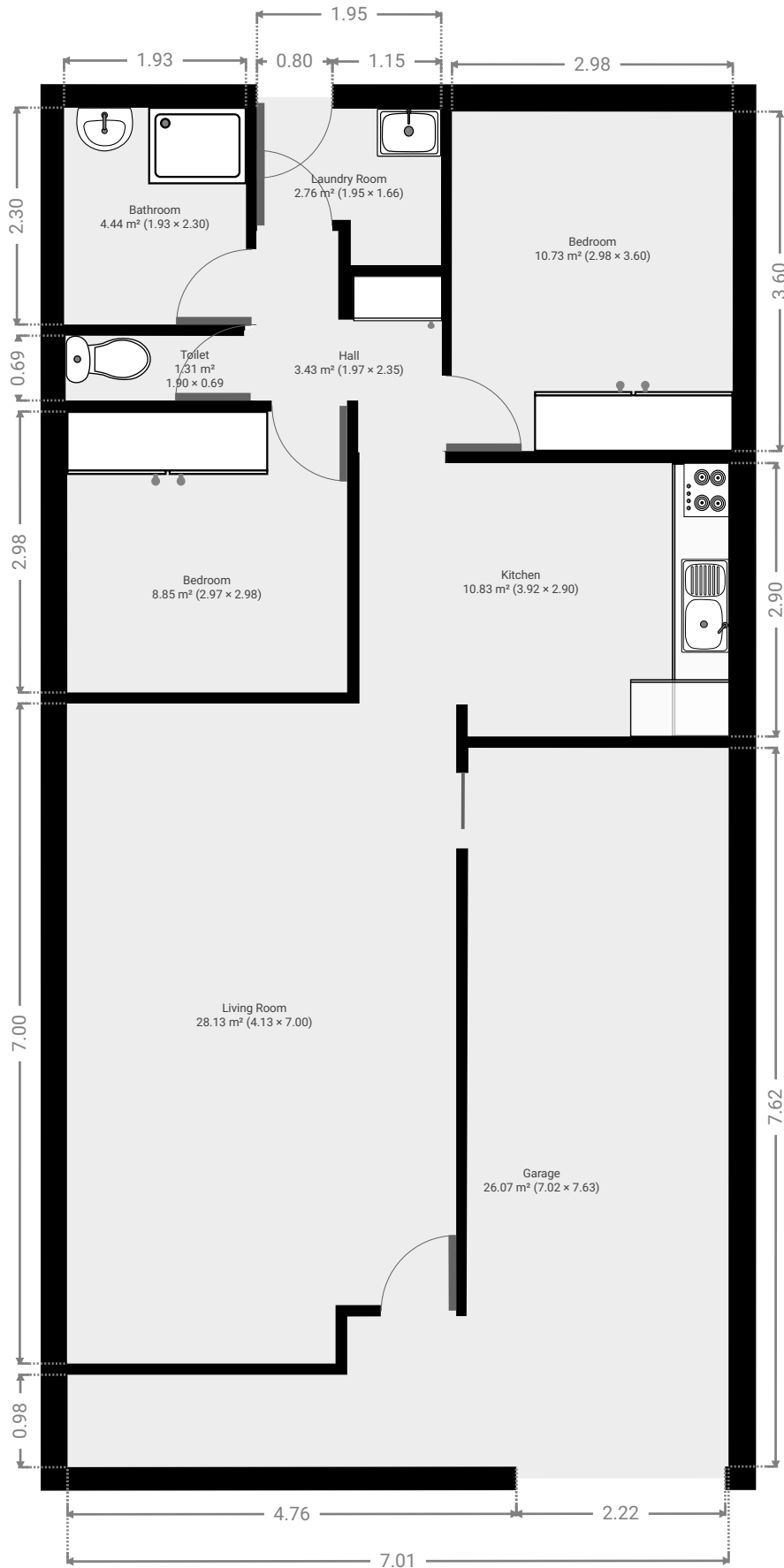

▼ Living Room  
Ground Floor

WIDTH: 4.13 m • LENGTH: 7.00 m  
AREA: 28.13 m<sup>2</sup> • PERIMETER: 22.27 m

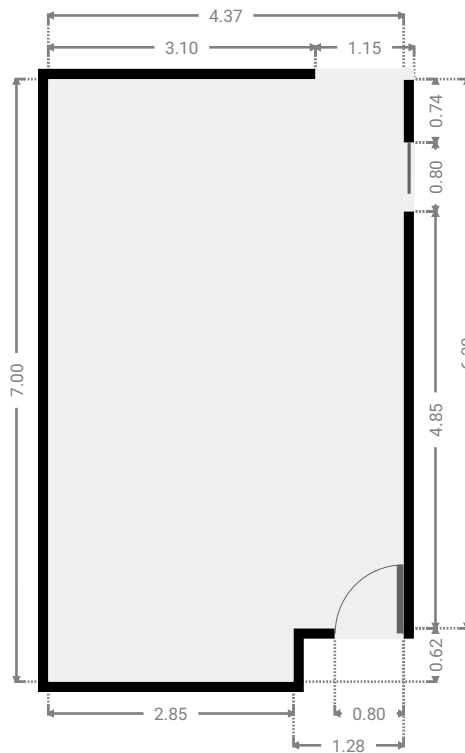
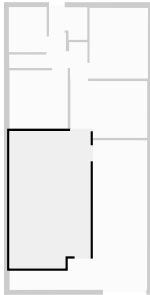

▼ Kitchen  
Ground Floor

WIDTH: 3.92 m • LENGTH: 2.90 m  
AREA: 10.83 m<sup>2</sup> • PERIMETER: 13.64 m

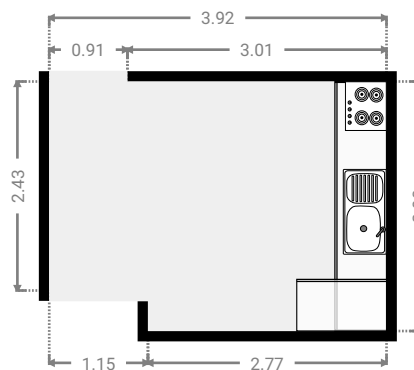
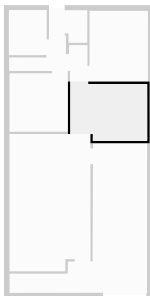

▼ **Hall**  
Ground Floor

WIDTH: 1.97 m • LENGTH: 2.35 m  
AREA: 3.43 m<sup>2</sup> • PERIMETER: 9.56 m

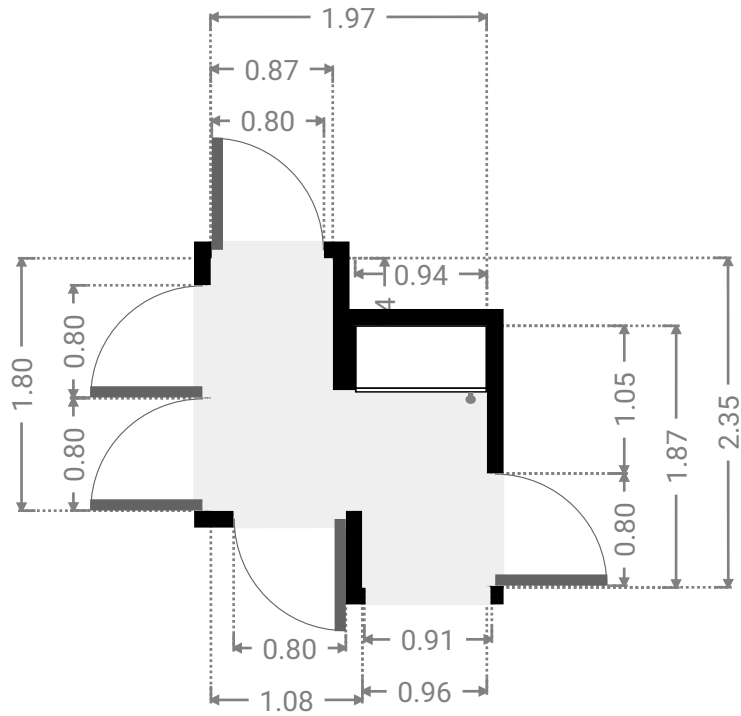
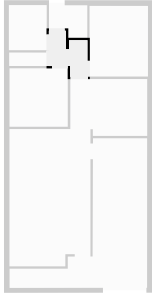

▼ **Bedroom**  
Ground Floor

WIDTH: 2.97 m • LENGTH: 2.98 m  
AREA: 8.85 m<sup>2</sup> • PERIMETER: 11.90 m

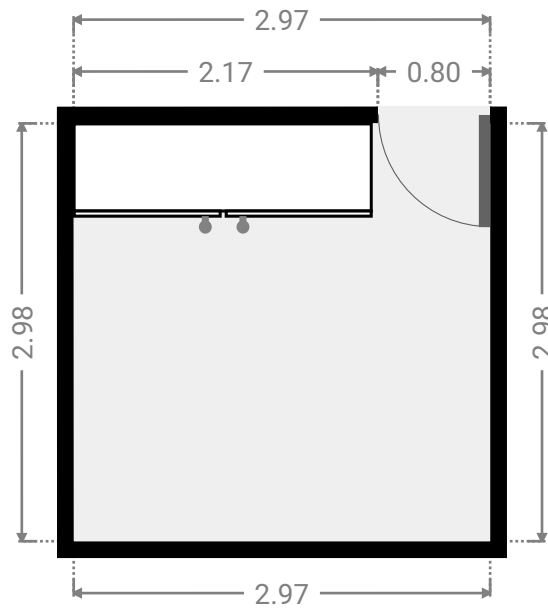
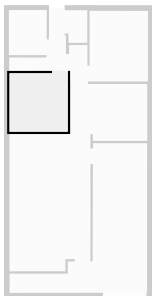

▼ **Toilet**  
Ground Floor

WIDTH: 1.90 m • LENGTH: 0.69 m  
AREA: 1.31 m<sup>2</sup> • PERIMETER: 5.18 m

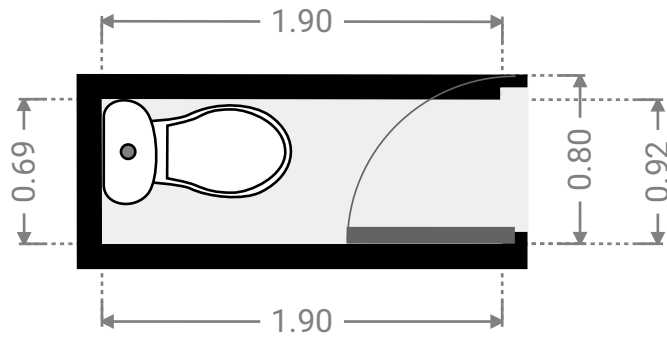
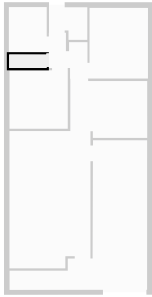

▼ **Bathroom**  
Ground Floor

WIDTH: 1.93 m • LENGTH: 2.30 m  
AREA: 4.44 m<sup>2</sup> • PERIMETER: 8.46 m

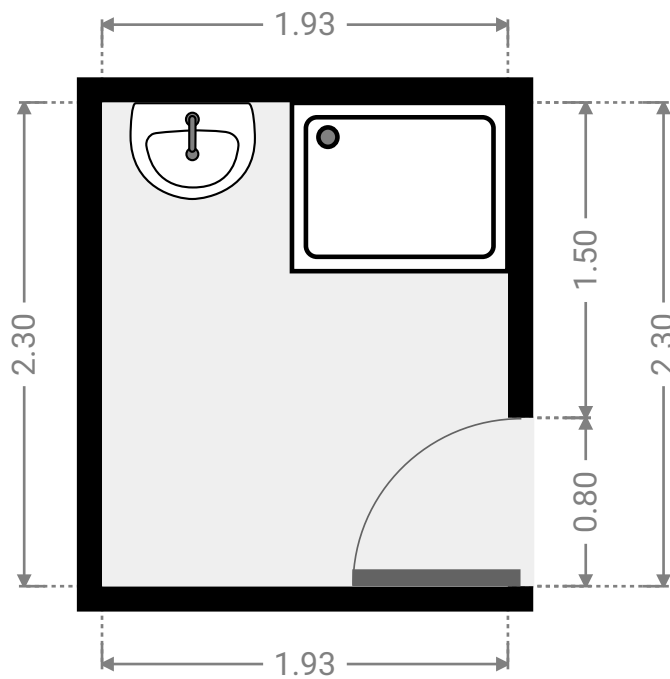
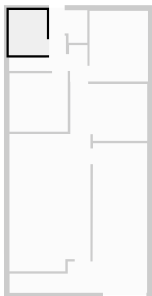

▼ **Laundry Room**  
Ground Floor

WIDTH: 1.95 m • LENGTH: 1.66 m  
AREA: 2.76 m<sup>2</sup> • PERIMETER: 7.23 m

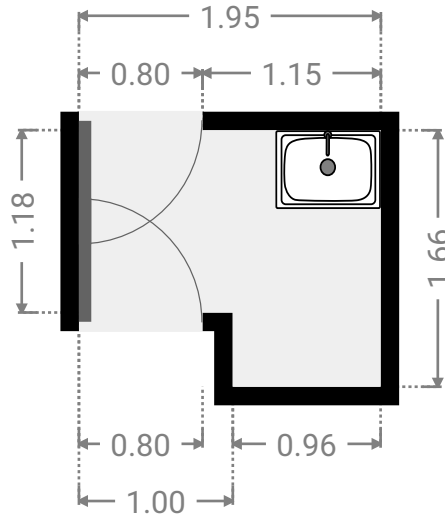
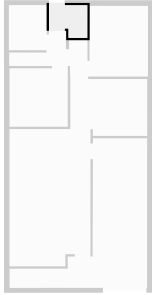

▼ **Bedroom**  
Ground Floor

WIDTH: 2.98 m • LENGTH: 3.60 m  
AREA: 10.73 m<sup>2</sup> • PERIMETER: 13.16 m

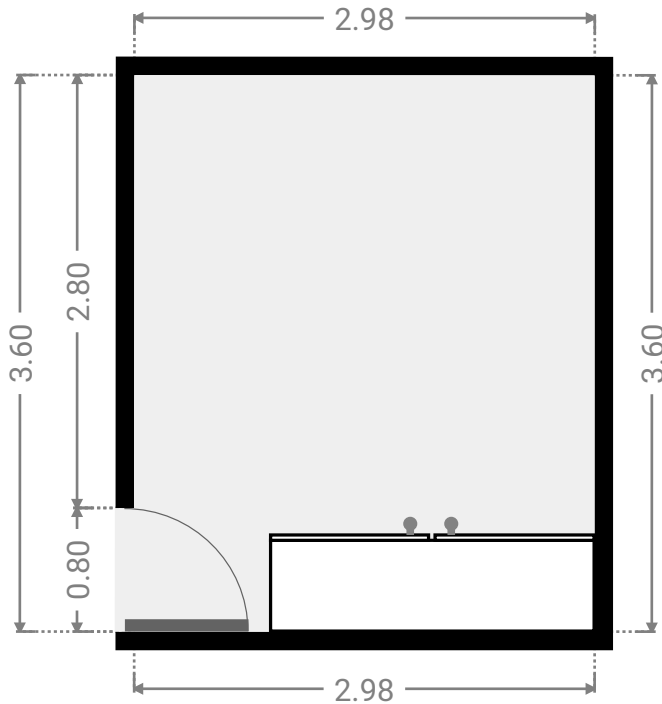
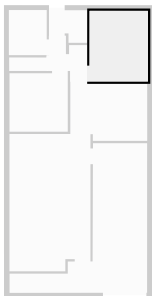

▼ **Garage**  
Ground Floor

WIDTH: 7.02 m • LENGTH: 7.63 m  
AREA: 26.07 m<sup>2</sup> • PERIMETER: 29.26 m

